

SWING CHECK VALVE FLANGED END JIS 10K

Model : ARV-103FE(J)

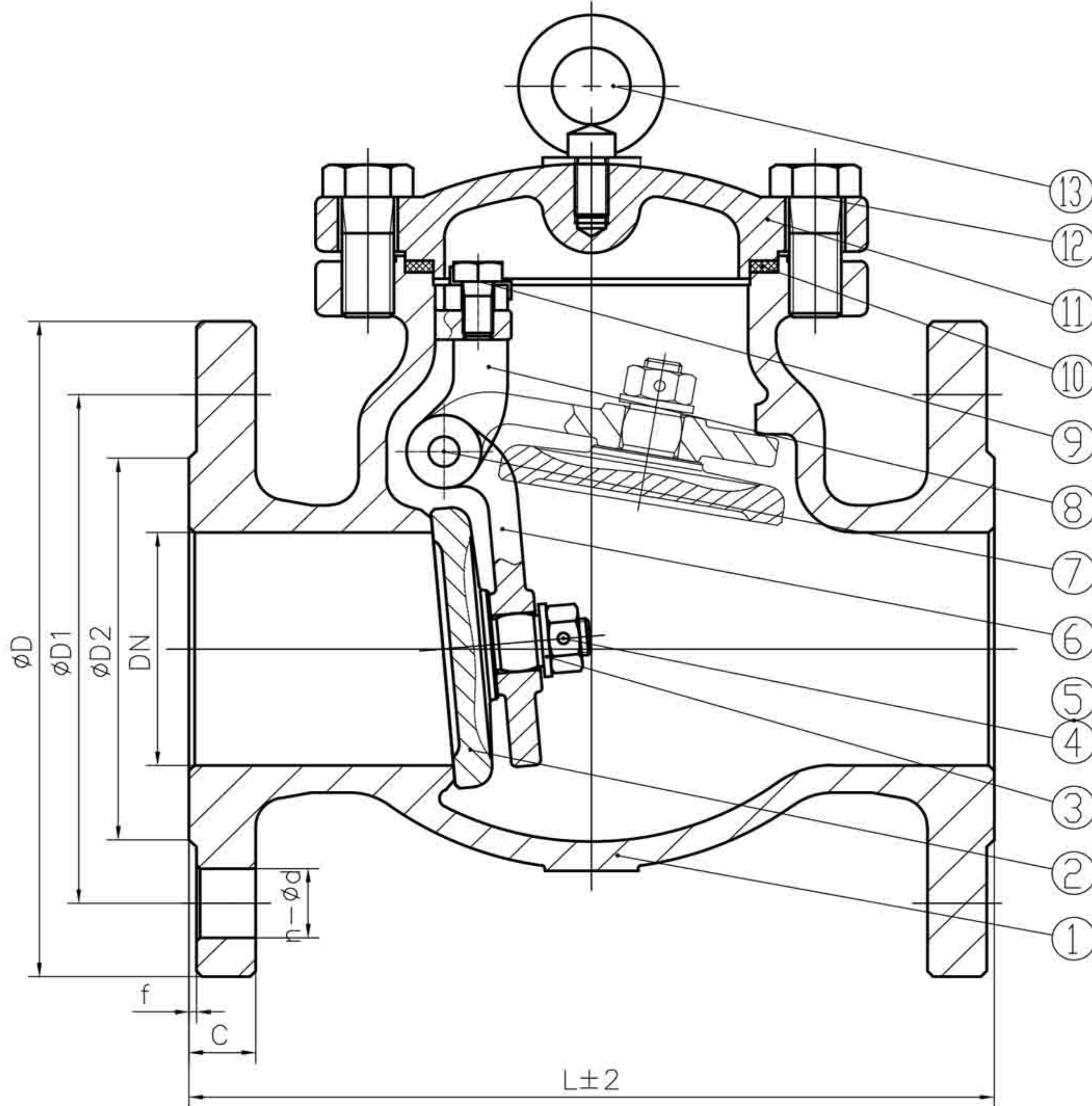

Features :

Design and manufacture according to JIS B2071-2000

Face to Face : JIS B2002-1987

End Flange dimension according to JIS B2220-2012

Inspection and Test : JIS B2003-1994

Material

No	PART	MATERIAL	
1	BODY	A351 CF8	A351 CF8M
2	DISC	A351 CF8	A351 CF8M
3	WASHER	SS304	SS316
4	NUT PIN	SS304	SS316
5	NUT	SS304	SS316
6	SWAY STAFF	A351 CF8	A351 CF8M
7	HINGE PIN	SS304	SS316
8	HINGE	A351 CF8	A351 CF8M
9	BOLT	SS304	SS316
10	GASKET	SPIRAL WOUND GASKETS	
11	BONNET	A351 CF8	A351 CF8M
12	BOLT	A193 B8	A193 B8M
13	EYE BOLT	C.S	

Nominal pressure	10K	
Test Pressure	Shell Test	2.4 Mpa
Applicable Medium	Water, Oil, Gas	
Applicable Temperature	-29 ~ 425 °C	

Dimension in mm

SIZE		L	D	D1	D2	C	f	n-Ød
DN	in.							
15	1/2"	108	95	70	52	12	1	4-Ø15
20	3/4"	117	100	75	58	14	1	4-Ø15
25	1"	127	125	90	70	14	1	4-Ø19
32	1.1/4"	140	135	100	80	16	2	4-Ø19
40	1.1/2"	165	140	105	85	16	2	4-Ø19
50	2"	203	155	120	100	16	2	4-Ø19
65	2.1/2"	216	175	140	120	18	2	4-Ø19
80	3"	241	185	150	130	18	2	8-Ø19
100	4"	292	210	175	155	18	2	8-Ø19
125	5"	330	250	210	185	20	2	8-Ø23
150	6"	356	280	240	215	22	2	8-Ø23
200	8"	495	330	290	265	22	2	12-Ø23
250	10"	622	400	355	325	24	2	12-Ø25
300	12"	698	445	400	368	24	2	16-Ø25
350	14"	787	535	476.3	413	35.4	2	12-Ø29

The contents of this literature are for informative purposes only. Arita is not responsible for suitability or compatibility of these products in relation to system requirement. For specific requirements, consult Arita or its distributors. Arita reserves the right to change or modify product design without prior notice.