

SWING CHECK VALVE FLANGED END JIS 10K

Model : ARV-103FE(A)

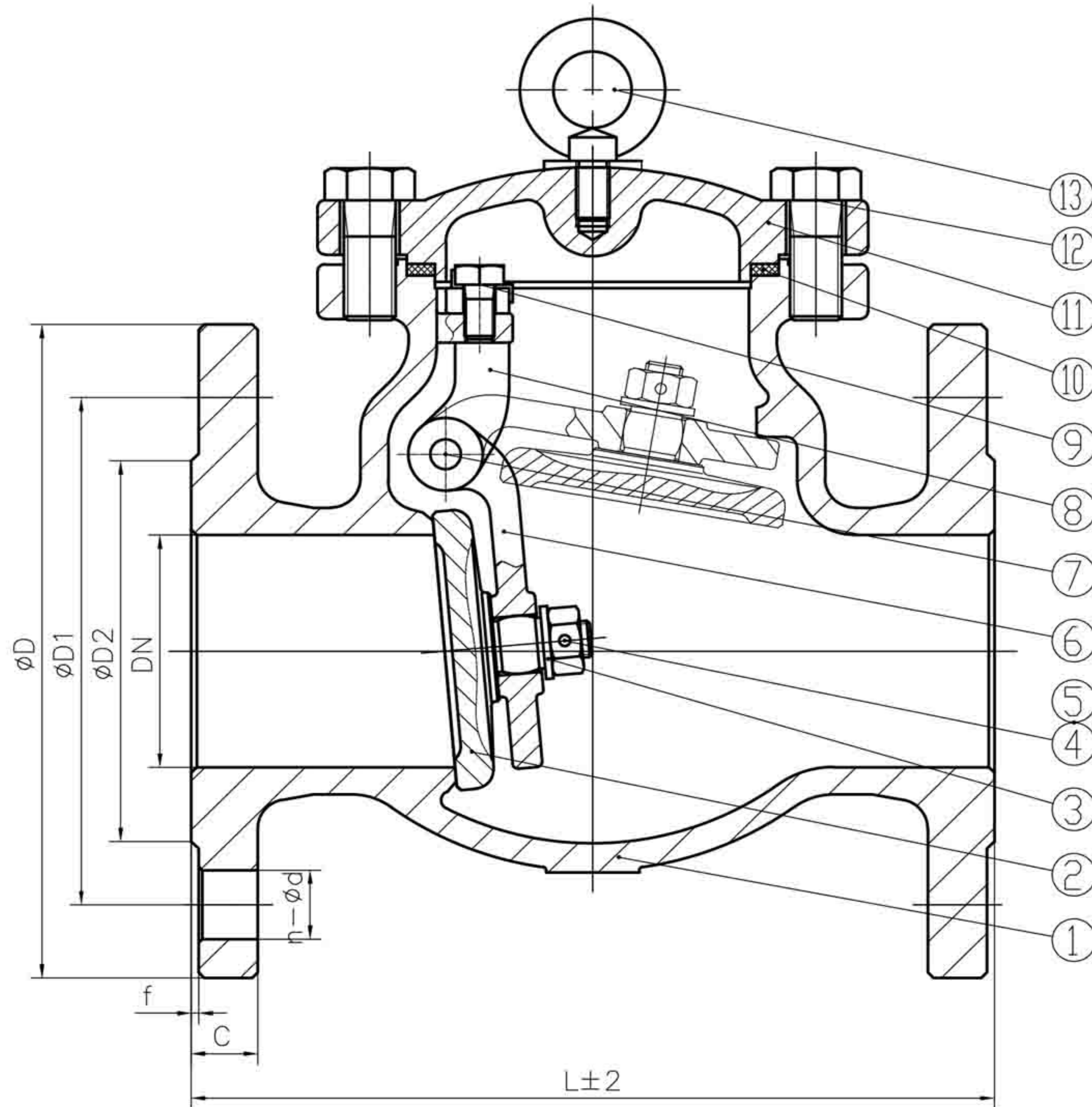

Features :

Design and manufacture according to ANSI B16.34-2009

Face to Face : ASME B16.10-2009

End Flange dimension according to ASME B16.5-2009

Inspection and Test : API 598-2009

Material

No	PART	MATERIAL	
1	BODY	A351 CF8	A351 CF8M
2	DISC	A351 CF8	A351 CF8M
3	WASHER	SS304	SS316
4	NUT PIN	SS304	SS316
5	NUT	SS304	SS316
6	SWAY STAFF	A351 CF8	A351 CF8M
7	HINGE PIN	SS304	SS316
8	HINGE	A351 CF8	A351 CF8M
9	BOLT	SS304	SS316
10	GASKET	SPIRAL WOUND GASKETS	
11	BONNET	A351 CF8	A351 CF8M
12	BOLT	A193 B8	A193 B8M
13	EYE BOLT	C.S	

Nominal pressure	150 LB	
Test Pressure	Shell Test	3.0 Mpa
Applicable Medium	Water, Oil, Gas	
Applicable Temperature	-29 ~ 425 °C	

Dimension in mm

SIZE		L	D	D1	D2	C	f	n-Ød
DN	in.							
15	1/2"	108	90	60.3	34.9	10	2	4-Ø16
20	3/4"	117	100	69.9	42.9	11	2	4-Ø16
25	1"	127	110	79.4	50.8	12	2	4-Ø16
32	1.1/4"	140	115	88.9	63.5	13	2	4-Ø16
40	1.1/2"	165	125	98.4	73	15	2	4-Ø16
50	2"	203	150	120.7	92.1	16	2	4-Ø19
65	2.1/2"	216	180	139.7	104.8	18	2	4-Ø19
80	3"	241	190	152.4	127	19	2	4-Ø19
100	4"	292	230	190.5	157.2	24	2	8-Ø19
125	5"	330	255	215.9	185.7	24	2	8-Ø22
150	6"	356	280	241.3	215.9	26	2	8-Ø22
200	8"	495	345	298.5	269.9	29	2	8-Ø22
250	10"	622	405	362	323.8	31	2	12-Ø25
300	12"	698	485	431.8	381	32.2	2	12-Ø25
350	14"	787	490	445	413	-	3	16-Ø25

The contents of this literature are for informative purposes only. Arita is not responsible for suitability or compatibility of these products in relation to system requirement. For specific requirements, consult Arita or its distributors. Arita reserves the right to change or modify product design without prior notice.