

# Ball Valves



# KITZ Ball Valves

KITZ ball valves are manufactured under the same quality system designed according to ISO 9001, no matter where they are produced.



KITZ Corporation of Taiwan, Kaohsiung Plant, Taiwan (ISO 9001)



KITZ Corporation of Europe, S.A., Barcelona Plant, Spain (ISO 9001)



KITZ Corporation, Ina Plant, Japan (ISO 9001)



KITZ Corporation, Nagasaka Plant, Japan (ISO 9001)

## Contents

Product Range	1
Design Features (Flanged Floating Ball Valves)	9
Stainless Steel/Carbon Steel Ball Valves	12
Stainless Steel Pocketless Ball Valves	22
Stainless Steel Jacketed Ball Valves	22
Stainless Steel 3-way Ball Valves	23
Stainless Steel Tank Ball Valves	25
Stainless Steel PFA Lined Ball Valves	25
Stainless Steel/Carbon Steel (Uni-body) Ball Valves	26
Stainless Steel for Low Temperature Ball Valves	27
Ductile Iron Ball Valves	32
Ductile Iron Ball Valves for Gas Service	32
Ductile Iron 3-Way Ball Valves	33
Cast Iron Ball Valves	34
Cast Iron 3-Way Ball Valves	36
Bronze Ball Valves	36
Construction and Materials (Flanged Floating Ball Valves)	37
Design Features (A-Port Control Valves)	50
Design Data (A-Port Control Valves)	52
A-Port Control Valves	53
Component Drawing (T60S Soft Seated 3-Piece Body Trunnion Mounted Ball Valves)	55
Design Features (T60S Soft Seated 3-Piece Body Trunnion Mounted Ball Valves)	56
Component Drawing (T60M Metal Seated 3-Piece Body Trunnion Mounted Ball Valves)	58
Design Features (T60M Metal Seated 3-Piece Body Trunnion Mounted Ball Valves)	59
Stainless Steel/Carbon Steel (Trunnion) Ball Valves	60
Construction (Flanged Trunnion Mounted Ball Valves)	66
Stainless Steel Ball Valves (Threaded or Welding)	72
Ductile Iron Ball Valves (Threaded)	77
Ductile Iron Ball Valves for Gas Service (Threaded)	77
Cast Iron Ball Valves (Threaded)	77
Brass & Bronze Ball Valves (Threaded or Solder Joint)	78
Brass & Bronze 3-way Ball Valves (Threaded or Solder Joint)	87
Brass & Bronze Ball Valves for Gas Service (Threaded)	88
<b>■ Technical Information</b>	
KITZ Ball Seat Materials	91
Technical Data	92
Dimensions of Actuator Mounting Pads	93
Pressure-Temperature Ratings	95
Allowable Port Orientation	106
General Precautions	107
Flow Characteristics	108

# Product Range

## Flanged Floating Ball Valves

Shell Material	Class	KITZ Product Code	Bore *1	Design Body	Nominal Size	NPS	Nominal Size																	Page
							DN	1/2	3/4	1	1 1/4	1 1/2	2	2 1/2	3	4	5	6	8	10	12	300		
Carbon Steel	Class 150	150SCTDZ	F	Split			●	●	●		●	●	●	●	●	●	●	●	●		14			
	Class 150	G-150SCTDZ	F	Split													▲	●	●	●		14		
	Class 150	150SCTAZM	R	Uni			▲	▲	▲		▲	▲		▲	▲		▲	▲	▲		26			
	Class 300	300SCTDZ	F	Split			●	●	●		●	●	●	●	▲	●	●	●			14			
	Class 300	G-300SCTDZ	F	Split											●	▲	●	●			14			
	Class 300	300SCTAZM	R	Uni			▲	▲	▲		▲	▲		▲	▲		▲	▲	▲		26			
	Class 600	600SCTB	F	Split			●	●	●		●										13			
	Class 1500	1500SCTB	F	Split			●	●	●		●										13			
	Class 150	150SCTR	R	Split												●	●	●	●		*3			
	Class 150	G-150SCTR	R	Split												●	●	●	●		*3			
	Class 300	300SCTR	R	Split												●	●	●	●		*3			
	Class 300	G-300SCTR	R	Split												●	●	●	●		*3			
	10K	10SCTDZ	F	Split			●	●	●		●	●	●	●	●	●	●	●	●			*3		
	10K	G-10SCTDZ	F	Split												●	●	●	●		*3			
	20K	20SCTDZ	F	Split			●	●	●		●	●	●	●	●	●	●	●	●			*3		
20K	G-20SCTDZ	F	Split												▲	▲	●	●		*3				
Stainless Steel	Class 150	150UTDZ	F	Split			●	●	●	●	●	●	●	●	●	●	●	●	●		14			
	Class 150	150UTDZM	F	Split			●	●	●	●	●	●	●	●	●	●	●	●	●		14			
	Class 150	G-150UTDZ	F	Split												●	●	●	●		14			
	Class 150	G-150UTDZM	F	Split												●	●	●	●		14			
	Class 150	150UTB	F	Split			●	●	●		●	●	●	●	●	●	●	●	●		12			
	Class 150	150UTBM	F	Split			●	●	●		●	●	●	●	●	●	●	●	●		12			
	Class 150	G-150UTB	F	Split											▲	▲	●	●	●	●	12			
	Class 150	G-150UTBM	F	Split											▲	▲	●	●	●	●	12			
	Class 150	150UTAZM	R	Uni			●	●	●		●	●		●	●		●	●	●		26			
	Class 150	G-150UTAZM	R	Uni			●	●	●		●	●		●	●		▲	●	●		26			
	Class 300	300UTDZ	F	Uni			●	●	●	▲	●	●	●	●	●	▲	●	●			14			
	Class 300	300UTDZM	F	Uni			●	●	●	▲	●	●	●	●	●	▲	●	●			14			
	Class 300	G-300UTDZ	F	Uni											●	▲	●	●			14			
	Class 300	G-300UTDZM	F	Uni											●	▲	●	●			14			
	Class 300	300UTAZM	R	Uni			●	●	●		●	●		●	●		●	●	●		26			
	Class 300	G-300UTAZM	R	Uni													▲	●	●		26			
	Class 600	600UTB	F	Uni			●	●	●		●										13			
	Class 600	600UTBM	F	Uni			●	●	●		●										13			
	Class 1500	1500UTB	F	Uni			●	●	●		●										13			
	Class 1500	1500UTBM	F	Uni			●	●	●		●										13			
	Class 150	150UTDZXL	F	Split/Extended bonnet			●	●	●	●	●	●	●	●	●	●					30			
	Class 150	150UTDZXML	F	Split/Extended bonnet			●	●	●	▲	●	●	▲	●	●						30			
	Class 150	G-150UTDZXL	F	Split/Extended bonnet											▲	▲	●	●	●	●	30			
	Class 150	G-150UTDZXML	F	Split/Extended bonnet											▲	▲	▲	▲	▲	▲	30			
	Class 300	300UTDZXL	F	Split/Extended bonnet			●	●	●	●	●	●	●	●							31			
	Class 300	300UTDZXML	F	Split/Extended bonnet			●	●	●	●	●	●	●	●							31			
	Class 300	G-300UTDZXL	F	Split/Extended bonnet											●		●	●			31			
	Class 300	G-300UTDZXML	F	Split/Extended bonnet											▲		▲	▲			31			
	Class 150	150UTAZLM	R	Uni/Extended bonnet			▲	▲	▲		▲	▲		▲	▲						27			
	Class 150	G-150UTAZLM	R	Uni/Extended bonnet													▲	▲	▲		27			
	Class 300	300UTAZLM	R	Uni/Extended bonnet			▲	▲	▲		▲	▲		▲	▲			▲	▲	▲	27			
	Class 300	G-300UTAZLM	R	Uni/Extended bonnet													▲	▲	▲		27			
	Class 150	150UTDZL	F	Split/Extended bonnet			●	●	●	●	●	●	●	●							28			
	Class 150	150UTDZLM	F	Split/Extended bonnet			▲	●	▲	▲	▲	●	▲	▲							28			
	Class 150	G-150UTDZL	F	Split/Extended bonnet											●	●	●	●	●		28			
	Class 150	G-150UTDZLM	F	Split/Extended bonnet											▲	▲	▲	▲	▲		28			
	Class 300	300UTDZL	F	Split/Extended bonnet			●	●	●		●	●	●		▲						29			
	Class 300	300UTDZLM	F	Split/Extended bonnet			▲	▲	●		●	●	▲	▲							29			
	Class 300	G-300UTDZL	F	Split/Extended bonnet											●	●		●	●		29			
	Class 300	G-300UTDZLM	F	Split/Extended bonnet											▲	▲		▲	▲		29			
10K	10UTDZL	F	Split/Extended bonnet			●	▲	●	▲	▲	▲	▲	▲							28				
10K	G-10UTDZL	F	Split/Extended bonnet												▲	▲	▲	▲	▲	28				
20K	20UTDZL	F	Split/Extended bonnet			▲	●	●	▲	●	▲	▲	▲							29				
20K	20UTDZLM	F	Split/Extended bonnet			●	▲	▲	▲	▲	▲	▲	▲							29				
20K	G-20UTDZL	F	Split/Extended bonnet											●	●	▲	▲	▲		29				

\*1 Bore design: F=Full bore, R=Reduced bore  
 \*2 Worm gear operation in standard for the Products with the prefix "G-"  
 \*3 Please contact KITZ Corporation for details.  
 ▲: Custom orders. Please contact KITZ Corporation.

# Product Range

## Flanged Floating Ball Valves

Shell Material	Class	KITZ Product Code	Bore *1	Design Body	Nominal Size	NPS DN	1/2	3/4	1	1 1/4	1 1/2	2	2 1/2	3	4	5	6	8	10	12	Page	
							15	20	25	32	40	50	65	80	100	125	150	200	250	300		
Stainless Steel	Class 150	150UTR	R	Split								●	●	●	●	●	●	●	●		*3	
	Class 150	150UTRM	R	Split								●	●	●	●	●	●	●	●	●		*3
	Class 150	G-150UTR	R	Split											▲	▲	●	●	●	●	●	*3
	Class 150	G-150UTRM	R	Split											▲	▲	●	●	●	●	●	*3
	Class 300	300UTR	R	Split								●	●	●	●	●	●	●	●	●	●	*3
	Class 300	300UTRM	R	Split								●	●	●	●	●	●	●	●	●	●	*3
	Class 300	G-300UTR	R	Split													●	●	●	●		*3
	10K	10UTDZ	F	Split				●	●	●	●	●	●	●	●	●	●	●	●	●		*3
	10K	10UTDZM	F	Split				●	●	●	●	●	●	●	●	●	●	●	●	●		*3
	10K	G-10UTDZ	F	Split											▲		●	●	●	●	●	*3
	10K	G-10UTDZM	F	Split											▲		●	●	●	●	●	*3
	20K	20UTDZ	F	Split				●	●	●	●	●	●	●	●	●	●	●	●	●		*3
	20K	20UTDZM	F	Split				●	●	●	●	●	●	●	●	●	●	●	●	●		*3
	20K	G-20UTDZ	F	Split											▲	●	●	●	●	●		*3
	20K	G-20UTDZM	F	Split											▲	●	●	●	●	▲		*3
	Class 150	150UTB2L	F	Split/3-way·2-seats					●		●	●		●	▲							23
	Class 150	150UTB2LM	F	Split/3-way·2-seats					▲		▲	▲		▲	▲							23
	Class 150	150UTB2T	F	Split/3-way·2-seats					▲		▲	▲		▲	▲							23
	Class 150	150UTB2TM	F	Split/3-way·2-seats					▲		▲	▲		▲	▲							23
	Class 150	150UTR2L	R	Split/3-way·2-seats													●					24
	Class 150	150UTR2LM	R	Split/3-way·2-seats													●					24
	Class 150	150UTR2TM	R	Split/3-way·2-seats													●					24
	Class 150	150UTB4LA	F	Split/3-way·4-seats				●	●	●		●	●	●	●	●		▲				23
	Class 150	150UTB4LAM	F	Split/3-way·4-seats				●	●	●		●	●	●	●	●		▲				23
	Class 150	G-150UTB4LA	F	Split/3-way·4-seats													●	▲				23
	Class 150	150UTR4LA	R	Split/3-way·4-seats												▲	●	▲				24
	Class 150	150UTR4LAM	R	Split/3-way·4-seats												▲	●	▲				24
	Class 150	G-150UTR4LA	R	Split/3-way·4-seats													▲	▲	▲			24
	Class 150	150UTR4TA	R	Split/3-way·4-seats												▲	●	▲				24
	Class 150	150UTR4TAM	R	Split/3-way·4-seats												▲	●	▲				24
	10K	10UTB2L	F	Split/3-way·2-seats					●		●	●	●	●	●							*3
	10K	10UTB2LM	F	Split/3-way·2-seats					●		●	●	●	●	●							*3
	10K	10UTB2T	F	Split/3-way·2-seats					●		●	●	●	●	●							*3
	10K	10UTB2TM	F	Split/3-way·2-seats					●		●	●	●	●	●							*3
	10K	10UTR2L	R	Split/3-way·2-seats													●					*3
	10K	10UTR2LM	R	Split/3-way·2-seats													●					*3
	10K	10UTR2T	R	Split/3-way·2-seats													●					*3
	10K	10UTR2TM	R	Split/3-way·2-seats													●					*3
	10K	10UTB4LA	F	Split/3-way·4-seats				●	●	●		●	●	●	●	●	▲	▲				*3
	10K	10UTB4LAM	F	Split/3-way·4-seats				●	●	●		●	●	●	●	●	▲	▲				*3
	10K	G-10UTB4LA	F	Split/3-way·4-seats													▲	▲				*3
	10K	G-10UTB4LAM	F	Split/3-way·4-seats													▲	▲				*3
	10K	10UTB4TA	F	Split/3-way·4-seats				●	●	●		●	●	●	●	●	●	●				*3
	10K	10UTB4TAM	F	Split/3-way·4-seats				●	●	●		●	●	●	●	●	●	●				*3
	10K	G-10UTB4TA	F	Split/3-way·4-seats												▲	▲	▲	▲			*3
	10K	G-10UTB4TAM	F	Split/3-way·4-seats												▲	▲	▲	▲			*3
	10K	10UTR4LA	R	Split/3-way·4-seats													●	●	●			*3
	10K	10UTR4LAM	R	Split/3-way·4-seats													●	●	●			*3
	10K	G-10UTR4LA	R	Split/3-way·4-seats													▲	▲	▲			*3
	10K	G-10UTR4LAM	R	Split/3-way·4-seats													▲	▲	▲			*3
10K	10UTR4TA	R	Split/3-way·4-seats													●	●	●			*3	
10K	10UTR4TAM	R	Split/3-way·4-seats													●	●	●			*3	
10K	G-10UTR4TA	R	Split/3-way·4-seats													▲	●	●			*3	
10K	G-10UTR4TAM	R	Split/3-way·4-seats													▲	▲	▲			*3	
Class 150	150UTBP	F	Split/Pocketless				●	●	●		●	●	●	●	●	●	●	●			22	
Class 150	150UTBPM	F	Split/Pocketless				●	●	●		●	●	●	●	●	●	●	●			22	
Class 150	G-150UTBP	F	Split/Pocketless														▲	▲			22	
Class 150	G-150UTBPM	F	Split/Pocketless														▲	▲			22	
Class 150	150UTBJ	F	Jacketed				●	●	●		●	●	●								22	
Class 150	150UTBJM	F	Jacketed				●	●	●		●	●	●								22	
10K	10UTBJ	F	Jacketed				●	●	●		●	●	●	●							*3	

\*1 Bore design: F=Full bore, R=Reduced bore  
 \*2 Worm gear operation in standard for the Products with the prefix "G-"  
 \*3 Please contact KITZ Corporation for details.  
 ▲: Custom orders. Please contact KITZ Corporation.





# Product Range

## Flanged Ball Valves

Shell Material	Nominal Pressure	KITZ Product Code	Bore *1	Nominal Size Body Design	NPS DN	1/2	3/4	1	1 1/4	1 1/2	2	2 1/2	3	4	5	6	8	10	12	14	Page		
						15	20	25	32	40	50	65	80	100	125	150	200	250	300	350			
^-port Stainless Steel	Class 150	L-150UVC *2	F	Split/For control				▲		●	●	●	●	●	●	●					53		
	Class 150	L-150UVCM *2	F	Split/For control				▲		▲	▲	▲	▲	▲	▲	▲	▲					53	
	Class 150	L-150UVCT *2	F	Split/For control				●		●	●	●	●	●	●	●	●					53	
	Class 150	L-150UVCTM *2	F	Split/For control				▲		▲	▲	▲	▲	▲	▲	▲	▲					53	
	Class 150	G-150UVC *2	F	Split/For control													▲	▲	●	▲		53	
	Class 150	G-150UVCM *2	F	Split/For control													▲	▲	▲	▲		53	
	Class 150	G-150UVCT *2	F	Split/For control													▲	▲	●	▲		53	
	Class 150	G-150UVCTM *2	F	Split/For control													▲	▲	▲	▲		53	
	Class 300	L-300UVC *2	F	Split/For control					●		●	●	●	●	●	●	●	●					54
	Class 300	L-300UVCM *2	F	Split/For control					●		●	●	●	●	●	●	●	●					54
	Class 300	L-300UVCT *2	F	Split/For control					●		●	●	●	●	●	●	●	●					54
	Class 300	L-300UVCTM *2	F	Split/For control					●		●	●	●	●	●	●	●	●					54
	Class 300	G-300UVC *2	F	Split/For control													●	●	●				54
	Class 300	G-300UVCM *2	F	Split/For control													●	●	●				54
	Class 300	G-300UVCT *2	F	Split/For control													●	●	●				54
	Class 300	G-300UVCTM *2	F	Split/For control													●	●	●				54
	10K	L-10UVC *2	F	Split/For control					●		●	●	●	●	●	●	●	●					53
	10K	L-10UVCM *2	F	Split/For control					●		●	●	●	●	●	●	●	●					53
	10K	L-10UVCT *2	F	Split/For control					●		●	●	●	●	●	●	●	●					53
	10K	L-10UVCTM *2	F	Split/For control					●		●	●	●	●	●	●	●	●					53
	10K	G-10UVC *2	F	Split/For control													▲	●	●	●	▲	▲	53
	10K	G-10UVCM *2	F	Split/For control													▲	▲	▲	▲	▲	▲	53
	10K	G-10UVCT *2	F	Split/For control													▲	●	●	●	▲	▲	53
	10K	G-10UVCTM *2	F	Split/For control													▲	▲	▲	▲	▲	▲	53
	20K	L-20UVC *2	F	Split/For control					●		●	●	●	●	●		▲						54
	20K	L-20UVCM *2	F	Split/For control					●		▲	▲	▲	▲	▲		▲						54
	20K	L-20UVCT *2	F	Split/For control					▲		▲	●	▲	▲	▲		▲						54
	20K	L-20UVCTM *2	F	Split/For control					▲	▲	▲	▲	▲	▲	▲		▲						54
	20K	G-20UVC *2	F	Split/For control													▲		▲				54
	20K	G-20UVCM *2	F	Split/For control													▲		▲				54
20K	G-20UVCT *2	F	Split/For control													▲		▲				54	
FILLTITE® Seated Carbon and Stainless Steel	Class 150	150SCTDZ1H	F	Split/Max. 300°C		●	●	●		●	●	●	●	●								15	
	Class 150	G-150SCTDZ1H	F	Split/Max. 300°C												●	●	●	●			15	
	Class 150	150UTDZ1H	F	Split/Max. 300°C		●	●	●	●	●	●	●	●	●									15
	Class 150	150UTDZ1HM	F	Split/Max. 300°C		●	●	●	●	●	●	●	●	●									15
	Class 150	G-150UTDZ1H	F	Split/Max. 300°C												●	●	●	●				15
	Class 150	G-150UTDZ1HM	F	Split/Max. 300°C												●	●	●	●				15
	Class 300	300SCTDZ1H	F	Split/Max. 300°C		●	●	●		●	●	●	●										15
	Class 300	G-300SCTDZ1H	F	Split/Max. 300°C											●	▲	●	●					15
	Class 300	300UTDZ1H	F	Split/Max. 300°C		●	●	●	▲	●	●	●	●										15
	Class 300	300UTDZ1HM	F	Split/Max. 300°C		●	●	●	▲	●	●	●	●										15
	Class 300	G-300UTDZ1H	F	Split/Max. 300°C											●	▲	●	●					15
	Class 300	G-300UTDZ1HM	F	Split/Max. 300°C											●	▲	●	●					15
	10K	10SCTDZ1H	F	Split/Max. 300°C		●	●	●		●	●	●	●	●									*4
	10K	G-10SCTDZ1H	F	Split/Max. 300°C												●	●	●	●				*4
	10K	10UTDZ1H	F	Split/Max. 300°C		●	●	●	●	●	●	●	●	●									*4
	10K	10UTDZ1HM	F	Split/Max. 300°C		●	●	●	●	●	●	●	●	●									*4
	10K	G-10UTDZ1H	F	Split/Max. 300°C												●	●	●	●				*4
	10K	G-10UTDZ1HM	F	Split/Max. 300°C												●	●	●	●				*4
	20K	20SCTDZ1H	F	Split/Max. 300°C		●	●	●		●	●	●	●										*4
	20K	G-20SCTDZ1H	F	Split/Max. 300°C												●	●	●	●				*4
20K	20UTDZ1H	F	Split/Max. 300°C		●	●	●	●	●	●	●	●	●									*4	
20K	20UTDZ1HM	F	Split/Max. 300°C		●	●	●	●	●	●	●	●	●									*4	
20K	G-20UTDZ1H	F	Split/Max. 300°C												●	●	●	●				*4	
20K	G-20UTDZ1HM	F	Split/Max. 300°C												●	●	●	●				*4	

\*1 Bore design: F=Full bore  
 \*2 Operation: L=Lever, G=Gear  
 \*3 Worm gear operation in standard for the Products with the prefix "G."  
 \*4 Please contact KITZ Corporation for details.  
 ▲: Custom orders. Please contact KITZ Corporation.

# Product Range

## Flanged Ball Valves

Shell Material	Nominal Pressure	KITZ Product Code	Bore *1	Body Design	Nominal Size	NPS DN	1/2	3/4	1	1 1/4	1 1/2	2	2 1/2	3	4	5	6	8	10	12	14	Page	
							15	20	25	32	40	50	65	80	100	125	150	200	250	300	350		
Graphite Seated Carbon and Stainless Steel	Class 150	150SCTDZ3H	F		Split/Max. 500°C		●	●	●		●	●	●	●	●							16	
	Class 150	G-150SCTDZ3H	F		Split/Max. 500°C											●	●	●				16	
	Class 150	150UTDZ3H	F		Split/Max. 500°C		●	●	●	●	●	●	●	●	●								16
	Class 150	150UTDZ3HM	F		Split/Max. 500°C		●	●	●	●	●	●	●	●	●								16
	Class 150	G-150UTDZ3H	F		Split/Max. 500°C										▲	●	●	●					16
	Class 150	G-150UTDZ3HM	F		Split/Max. 500°C										▲	●	●	●					16
	Class 300	300SCTDZ3H	F		Split/Max. 500°C		●	●	●		●	●	●	●									17
	Class 300	G-300SCTDZ3H	F		Split/Max. 500°C										●	▲	●	●					17
	Class 300	300UTDZ3H	F		Split/Max. 500°C		●	●	●	▲	●	●	●	●									17
	Class 300	300UTDZ3HM	F		Split/Max. 500°C		●	●	●	▲	●	●	●	●									17
	Class 300	G-300UTDZ3H	F		Split/Max. 500°C										●	▲	●	●					17
	Class 300	G-300UTDZ3HM	F		Split/Max. 500°C										●	▲	●	●					17
	10K	10SCTDZ3H	F		Split/Max. 300°C		●	●	●		●	●	●	●	●								16
	10K	G-10SCTDZ3H	F		Split/Max. 300°C											●	●	●					16
	10K	10UTDZ3H	F		Split/Max. 300°C		●	●	●	●	●	●	●	●	●								16
	10K	10UTDZ3HM	F		Split/Max. 300°C		●	●	●	●	●	●	●	●	●								16
	10K	G-10UTDZ3H	F		Split/Max. 300°C											●	●	●					16
	10K	G-10UTDZ3HM	F		Split/Max. 300°C											●	●	●					16
	20K	20SCTDZ3H	F		Split/Max. 425°C		●	●	●		●	●	●	●									17
	20K	G-20SCTDZ3H	F		Split/Max. 425°C											●	●	●	●				17
20K	20UTDZ3H	F		Split/Max. 425°C		●	●	●	●	●	●	●	●									17	
20K	20UTDZ3HM	F		Split/Max. 425°C		●	●	●	●	●	●	●	●									17	
20K	G-20UTDZ3H	F		Split/Max. 425°C										●	●	●	●					17	
20K	G-20UTDZ3HM	F		Split/Max. 425°C										●	●	●	●					17	
Metal Seated Carbon and Stainless Steel	Class 150	150SCTDZ5H	F		Split/Max. 300°C		●	●	●		●	●	●	●	●								18
	Class 150	G-150SCTDZ5H	F		Split/Max. 300°C											●	●	●					18
	Class 150	150UTDZ5H	F		Split/Max. 300°C		●	●	●	●	●	●	●	●	●								18
	Class 150	150UTDZ5HM	F		Split/Max. 300°C		●	●	●	●	●	●	●	●	●								18
	Class 150	G-150UTDZ5H	F		Split/Max. 300°C											●	●	●					18
	Class 150	G-150UTDZ5HM	F		Split/Max. 300°C											●	●	●					18
	Class 300	300SCTDZ5H	F		Split/Max. 300°C		●	●	●		●	●	●	●									19
	Class 300	G-300SCTDZ5H	F		Split/Max. 300°C										●	▲	●	●					19
	Class 300	300UTDZ5H	F		Split/Max. 300°C		●	●	●	▲	●	●	●	●		▲							19
	Class 300	300UTDZ5HM	F		Split/Max. 300°C		●	●	●	▲	●	●	●	●		▲							19
	Class 300	G-300UTDZ5H	F		Split/Max. 300°C										●	▲	●	●					19
	Class 300	G-300UTDZ5HM	F		Split/Max. 300°C										●	▲	●	●					19
	10K	10SCTDZ5H	F		Split/Max. 300°C		●	●	●		●	●	●	●	●								18
	10K	G-10SCTDZ5H	F		Split/Max. 300°C											●	●	●					18
	10K	10UTDZ5H	F		Split/Max. 300°C		●	●	●	●	●	●	●	●	●								18
	10K	10UTDZ5HM	F		Split/Max. 300°C		●	●	●	●	●	●	●	●	●								18
	10K	G-10UTDZ5H	F		Split/Max. 300°C											●	●	●					18
	10K	G-10UTDZ5HM	F		Split/Max. 300°C											●	●	●					18
	20K	20SCTDZ5H	F		Split/Max. 300°C		●	●	●		●	●	●	●									19
	20K	G-20SCTDZ5H	F		Split/Max. 300°C											●	●	●	●				19
20K	20UTDZ5H	F		Split/Max. 300°C		●	●	●	●	●	●	●	●									19	
20K	20UTDZ5HM	F		Split/Max. 300°C		●	●	●	●	●	●	●	●									19	
20K	G-20UTDZ5H	F		Split/Max. 300°C										●	●	●	●					19	
20K	G-20UTDZ5HM	F		Split/Max. 300°C										●	●	●	●					19	

\*1 Bore design: F=Full bore  
 \*2 Worm gear operation in standard for the Products with the prefix "G-"  
 ▲: Custom orders. Please contact KITZ Corporation.

# Product Range

## Flanged Ball Valves

Shell Material	Nominal Pressure	KITZ Product Code	Bore *1	Nominal Size Body Design	NPS DN	1/2	3/4	1	1 1/4	1 1/2	2	2 1/2	3	4	5	6	8	10	12	14	Page	
						15	20	25	32	40	50	65	80	100	125	150	200	250	300	350		
Metal Seated Carbon and Stainless Steel	Class 150	150SCTDZ6H	F	Split/Max. 500°C		●	●	●		●	●	●	●	●							20	
	Class 150	G-150SCTDZ6H	F	Split/Max. 500°C											●	●	●				20	
	Class 150	150UTDZ6H	F	Split/Max. 500°C		●	●	●	●	●	●	●	●	●								20
	Class 150	150UTDZ6HM	F	Split/Max. 500°C		●	●	●	●	●	●	●	●	●								20
	Class 150	G-150UTDZ6H	F	Split/Max. 500°C											▲	●	●	●				20
	Class 150	G-150UTDZ6HM	F	Split/Max. 500°C											▲	●	●	●				20
	Class 300	300SCTDZ6H	F	Split/Max. 500°C		●	●	●		●	●	●	●									21
	Class 300	G-300SCTDZ6H	F	Split/Max. 500°C											●	▲	●	●				21
	Class 300	300UTDZ6H	F	Split/Max. 500°C		●	●	●	▲	●	●	●	●									21
	Class 300	300UTDZ6HM	F	Split/Max. 500°C		●	●	●	▲	●	●	●	●									21
	Class 300	G-300UTDZ6H	F	Split/Max. 500°C											●	▲	●	●				21
	Class 300	G-300UTDZ6HM	F	Split/Max. 500°C											●	▲	●	●				21
	10K	10SCTDZ6H	F	Split/Max. 300°C		●	●	●		●	●	●	●	●								20
	10K	G-10SCTDZ6H	F	Split/Max. 300°C												●	●	●				20
	10K	10UTDZ6H	F	Split/Max. 300°C		●	●	●	●	●	●	●	●	●	●							20
	10K	10UTDZ6HM	F	Split/Max. 300°C		●	●	●	●	●	●	●	●	●	●							20
	10K	G-10UTDZ6H	F	Split/Max. 300°C												●	●	●				20
	10K	G-10UTDZ6HM	F	Split/Max. 300°C												●	●	●				20
	20K	20SCTDZ6H	F	Split/Max. 425°C		●	●	●		●	●	●	●									21
	20K	G-20SCTDZ6H	F	Split/Max. 425°C											●	●	●	●				21
20K	20UTDZ6H	F	Split/Max. 425°C		●	●	●	●	●	●	●	●	●								21	
20K	20UTDZ6HM	F	Split/Max. 425°C		●	●	●	●	●	●	●	●	●								21	
20K	G-20UTDZ6H	F	Split/Max. 425°C											●	●	●	●				21	
20K	G-20UTDZ6HM	F	Split/Max. 425°C											●	●	●	●				21	

\* 1 Bore design: F=Full bore

\* 2 Worm gear operation in standard for the Products with the prefix "G-"

▲: Custom orders. Please contact KITZ Corporation.

## Flanged Trunnion Mounted Ball Valves

Shell Material	Nominal Pressure	KITZ Product Code	Bore *1	Nominal Size Body Design	NPS DN	2	3	4	6	8	10	12	14	16	18	20	22	24	Page	
						50	80	100	150	200	250	300	350	400	450	500	550	600		
Carbon Steel	Class 150	T60S/150SF3TCS	F	3-Piece/Fire-safe		●	●	●	●											60
	Class 150	T60S/G-150SF3TCS	F	3-Piece/Fire-safe						●	●	●	●	●	●	●	●	●	●	60
	Class 300	T60S/300SF3TCS	F	3-Piece/Fire-safe		●	●	●	●											61
	Class 300	T60S/G-300SF3TCS	F	3-Piece/Fire-safe						●	●	●	●	●	●	●	●	●	●	61
	Class 600	T60S/600SF3TCS	F	3-Piece/Fire-safe		●	●	●												62
	Class 600	T60S/G-600SF3TCS	F	3-Piece/Fire-safe					●	●	●	●	●	●	●	●	●	●	●	62
	Class 150	T60S/150SF3TCRS	R	3-Piece/Fire-safe			●	●	●	●										60
	Class 150	T60S/G-150SF3TCRS	R	3-Piece/Fire-safe							●	●	●	●	●	●	●	●	●	60
	Class 300	T60S/300SF3TCRS	R	3-Piece/Fire-safe			●	●	●	●										61
	Class 300	T60S/G-300SF3TCRS	R	3-Piece/Fire-safe							●	●	●	●	●	●	●	●	●	61
	Class 600	T60S/600SF3TCRS	R	3-Piece/Fire-safe			●	●	●	●										62
	Class 600	T60S/G-600SF3TCRS	R	3-Piece/Fire-safe							●	●	●	●	●	●	●	●	●	62
Stainless Steel	Class 150	T60S/150UF3TCSM	F	3-Piece/Fire-safe		●	●	●	●											60
	Class 150	T60S/G-150UF3TCSM	F	3-Piece/Fire-safe						●	●	●	●	●	●	●	●	●	●	60
	Class 300	T60S/300UF3TCSM	F	3-Piece/Fire-safe		●	●	●	●											61
	Class 300	T60S/G-300UF3TCSM	F	3-Piece/Fire-safe						●	●	●	●	●	●	●	●	●	●	61
	Class 600	T60S/600UF3TCSM	F	3-Piece/Fire-safe		●	●	●												62
	Class 600	T60S/G-600UF3TCSM	F	3-Piece/Fire-safe					●	●	●	●	●	●	●	●	●	●	●	62
	Class 150	T60S/150UF3TCRSM	R	3-Piece/Fire-safe			●	●	●	●										60
	Class 150	T60S/G-150UF3TCRSM	R	3-Piece/Fire-safe							●	●	●	●	●	●	●	●	●	60
	Class 300	T60S/300UF3TCRSM	R	3-Piece/Fire-safe			●	●	●	●										61
	Class 300	T60S/G-300UF3TCRSM	R	3-Piece/Fire-safe							●	●	●	●	●	●	●	●	●	61
	Class 600	T60S/600UF3TCRSM	R	3-Piece/Fire-safe			●	●	●											62
	Class 600	T60S/G-600UF3TCRSM	R	3-Piece/Fire-safe							●	●	●	●	●	●	●	●	●	62

\* 1 Bore design: F=Full bore, R: Reduced Bore

\* 2 Worm gear operation in standard for the Products with the prefix "G-"

\* 3 Non fire-safe types are also available.



## Product Range

### Flanged Trunnion Mounted Ball Valves

Shell Material	Nominal Pressure	KITZ Product Code	Bore *1	Body Design	Nominal Size	NPS DN	2	3	4	6	8	10	12	14	16	18	20	22	24	Page
							50	80	100	150	200	250	300	350	400	450	500	550	600	
Metal Seated Carbon and Stainless Steel	Class 150	T60M/150SF3TC6H	F	3-Piece/Max. 525°C			●													63
	Class 150	T60M/G-150SF3TC6H	F	3-Piece/Max. 525°C			●	●	●	●	●	●	●	●	●	●	●	●	●	63
	Class 150	T60M/150UF3TC6HM	F	3-Piece/Max. 525°C			●													63
	Class 150	T60M/G-150UF3TC6HM	F	3-Piece/Max. 525°C			●	●	●	●	●	●	●	●	●	●	●	●	●	63
	Class 300	T60M/300SF3TC6H	F	3-Piece/Max. 525°C			●													64
	Class 300	T60M/G-300SF3TC6H	F	3-Piece/Max. 525°C			●	●	●	●	●	●	●	●	●	●	●	●	●	64
	Class 300	T60M/300UF3TC6HM	F	3-Piece/Max. 525°C			●													64
	Class 300	T60M/G-300UF3TC6HM	F	3-Piece/Max. 525°C			●	●	●	●	●	●	●	●	●	●	●	●	●	64
	Class 600	T60M/G-600SF3TC6H	F	3-Piece/Max. 525°C			●	●	●	●	●	●	●	●	●	●	●	●	●	65
	Class 600	T60M/G-600UF3TC6HM	F	3-Piece/Max. 525°C			●	●	●	●	●	●	●	●	●	●	●	●	●	65
	Class 150	T60M/150SF3TCR6H	R	3-Piece/Max. 525°C			●													63
	Class 150	T60M/G-150SF3TCR6H	R	3-Piece/Max. 525°C			●	●	●	●	●	●	●	●	●	●	●	●	●	63
	Class 150	T60M/150UF3TCR6HM	R	3-Piece/Max. 525°C			●													63
	Class 150	T60M/G-150UF3TCR6HM	R	3-Piece/Max. 525°C			●	●	●	●	●	●	●	●	●	●	●	●	●	63
	Class 300	T60M/300SF3TCR6H	R	3-Piece/Max. 525°C			●													64
	Class 300	T60M/G-300SF3TCR6H	R	3-Piece/Max. 525°C			●	●	●	●	●	●	●	●	●	●	●	●	●	64
	Class 300	T60M/300UF3TCR6HM	R	3-Piece/Max. 525°C			●													64
	Class 300	T60M/G-300UF3TCR6HM	R	3-Piece/Max. 525°C			●	●	●	●	●	●	●	●	●	●	●	●	●	64
Class 600	T60M/G-600SF3TCR6H	R	3-Piece/Max. 525°C			●	●	●	●	●	●	●	●	●	●	●	●	●	65	
Class 600	T60M/G-600UF3TCR6HM	R	3-Piece/Max. 525°C			●	●	●	●	●	●	●	●	●	●	●	●	●	65	

\* 1 Bore design: F=Full bore, R: Reduced Bore

\* 2 Worm gear operation in standard for the Products with the prefix "G-"

### Threaded or Welded Ball Valves

Shell Material	Nominal Pressure	KITZ Product Code	Bore *1	Body Design	Nominal Size	NPS DN	1/4	3/8	1/2	3/4	1	1 1/4	1 1/2	2	2 1/2	3	Page
							8	10	15	20	25	32	40	50	65	80	
Carbon Steel	Type 600	SCTK *2	R	Uni/Threaded ends			●	●	●	●	●	●	●	●			70
	Class 800	800SCTK *3	R	Seal welded/Threaded or Socket welded ends			●	●	●	●	●	●	●	●			71,72
	Type 1500/2000	AKSCTHZM *4	R	Split/Threaded ends			●	●	●	●	●	●	●	●			70
	Type 1500/2000	AKSCTHWZM *4	R	Seal welded/Threaded ends			●	●	●	●	●	●	●	●			71
	Type 3000	3000SCTK *3	R	Seal welded/Threaded or Socket welded ends			●	●	●	●	●	●	●	●			71,72
Stainless Steel	Type 600	UTKM *2	R	Uni/Threaded ends			●	●	●	●	●	●	●	●			72
	Type 800	UTHM *2	R	Split/Threaded ends					●	●	●	●	●	●			73
	Type 1000	UTFM *2	F	Split/Threaded ends					●	●	●	●	●	●			73
	Type 800	UTH4LM/4TM	R	Split/3-way·4-seat/Threaded ends					●	●	●	●	●	●			76
	Type 1000	U3TZFM *3	F	3-piece/Threaded or Socket welded ends			●	●	●	●	●	●	●	●			75
	Type 1000	U3TZM *3	R	3-piece/Threaded or Socket welded ends					●	●	●	●	●	●			75
	Type 1500/2000	AKUTHZM *4	R	Split/Threaded ends			●	●	●	●	●	●	●	●			74
	Type 1500/2000	AKUTHWZM *4	R	Seal welded/Threaded ends			●	●	●	●	●	●	●	●			74
10K	10UTM	F	Split/Threaded ends					▲	▲	▲	▲	▲	▲	▲	▲	▲	76
Ductile Iron	20K	20ST	R	Split/Threaded ends					●	●	●	●	●	●			77
	Type 400	STZ	R	Split/Threaded ends			●	●	●	●	●	●	●	●			77
Cast Iron	10K	10FCT	R	Split/Threaded ends				●	●	●	●	●	●	●	●	●	77

\* 1 Bore design: F=Full bore, R=Reduced bore

\* 2 Rc threaded ends are standard. Prefix "AK" means NPT threaded end.

\* 3 Rc threaded ends are standard. Prefix "AK" means NPT threaded ends and "AW" means socket welded ends.

\* 4 NPT threaded ends are only available.

# Product Range

## Threaded or Solder Joint Ball Valves

Shell Material	Class	KITZ Product Code	Bore *1	Design Body	Nominal Size	NPS DN	1/8	1/4	3/8	1/2	3/4	1	1 1/4	1 1/2	2	2 1/2	3	4	Page	
							6	8	10	15	20	25	32	40	50	65	80	100		
Bronze and Brass	600	AKTAF *2	F	2-Piece/Threaded ends			●	●	●	●	●	●	●	●					78	
	600	CTAF	F	2-Piece/Solder Joint ends				▲	▲	▲	▲	▲	▲	▲	▲	▲			78	
	600	AKTFLL *2	F	2-Piece/Threaded ends			●	●	●	●	●	●	●	●	●				78	
	600	CTFLL	F	2-Piece/Solder Joint ends					●	●	●	●	●	●	●				78	
	600	AKTAFM *2	F	2-Piece/Threaded ends				●	●	●	●	●	●	●	●				79	
	600	AKTAFP *2	F	2-Piece/Threaded ends				●	●	●	●	●	●	●	●	●	●	●		79
	600	AKTAFPM *2	F	2-Piece/Threaded ends				●	●	●	●	●	●	●	●	●	●	●		79
	600	AKTAFM *2	F	2-Piece/Threaded ends						●	●								80	
	600	CTAFM	F	2-Piece/Solder Joint ends						●	●								80	
	600	AKTAFO	F	2-Piece/Threaded ends (M&F)				●	●	●	●	●							80	
	600	AKTAFU *2	F	2-Piece/Threaded ends (F&Union)				●	●	●	●	●	●	●	●				80	
	600	AKTAFS *2	F	2-Piece/Threaded ends				●	●	●	●	●	●	●	●				81	
	400	TH	S	2-Piece/Threaded ends				●	●	●	●	●	●	●	●				81	
	600	CTH	S	2-Piece/Solder Joint ends				●	●	●	●	●	●	●	●	●	●		81	
	400	T	S	2-Piece/Threaded ends				●	●	●	●	●	●	●	●	●	●	●		81
	400	TT	S	2-Piece/Threaded ends				●	●	●	●	●	●	●	●				81	
	400	AKT *2	S	2-Piece/Solder Joint ends				●	●	●	●	●	●	●	●	●	●	●		81
	400	TO	S	2-Piece/Threaded ends (M&F)				●	●	●	●	●							82	
	400	TM	S	Split/Threaded ends					●	●	●	●	●	●	●	●	●		82	
	600	TK	R	Uni/Threaded ends			●	●	●	●	●	●	●	●	●				82	
	600	TKT	R	Uni/Threaded ends			●	●	●	●	●	●	●	●	●				82	
	600	AKTK *2	R	Uni/Threaded ends				●	●	●	●	●	●	●	●				82	
	600	TKW	R	Uni/Threaded ends			●	●	●	●	●	●	●	●	●				83	
	400	TF	F	2-Piece/Threaded ends					●	●	●	●	●	●	●				83	
	150	TFJ	F	2-Piece/Threaded ends						●	●	●	●	●	●				83	
	400	TL	S	2-Piece/Threaded ends						●	●	●	●	●	●				84	
	400	CTL	S	2-Piece/Solder Joint ends						●	●	●	●	●	●				84	
	400	TLT	S	2-Piece/Threaded ends						●	●	●	●	●	●				84	
	400	CTLTU	S	2-Piece/Solder Joint end & Union						●	●	●							84	
	600	AK3TM *2	F	2-Piece/Threaded ends				▲	▲	▲	▲	▲	▲	▲	▲				84	
	600	C3TM	F	3-Piece/Solder Joint ends					▲	▲	▲	▲	▲	▲	▲				84	
	600	ZO	F	2-Piece/Threaded ends (M&F)				●	●	●	●	●							85	
	400	ZS	S	2-Piece/Threaded ends				●	●	●	●	●	●	●	●				85	
	600	ZET	F	2-Piece/Threaded ends				●	●	●	●	●	●	●	●				85	
	600	AKSZA *2	F	2-Piece/Threaded ends				●	●	●	●	●	●	●	●	●	●	●		86
	600	CSZA	F	2-Piece/Solder Joint ends					▲	▲	▲	▲	▲	▲	▲	▲	▲	▲		86
	600	SZA	F	2-Piece/Threaded ends				●	●	●	●	●	●	●	●	●	●	●		86
	600	AKSZAW *2	F	2-Piece/Threaded ends				●	●	●	●	●	●	●	●				86	
	400	CSZAW	F	2-Piece/Solder Joint ends					●	●	●	●	●	●	●				86	
	400	TN	S	3-Way/Threaded ends				●	●	●	●	●	●	●	●	●	●	●		87
	400	AKTN *2	S	3-Way/Threaded ends				●	●	●	●	●	●	●	●	●	●	●		87
	400	T4T	S	3-Way/Threaded ends						●	●	●	●	●	●				87	
400	T4L	S	3-Way/Threaded ends						●	●	●	●	●	●				87		
400	AKTNP *2	S	3-Way/Threaded ends						●	●	●	●	●	●				87		
	TG	S	2-Piece/Threaded ends				●	●	●	●	●	●	●	●	●	●	●		88	

\*1 Bore design: F=Full bore, S=Standard (Regular) bore, R=Reduced bore  
 \*2 Rc threaded ends are standard. Prefix "AK" means NPT threaded end.

# Floating Ball Valves

## KITZ 150/300SCTDZ/UTDZM Series Full Bore, Split Body, Side Entry Ball Valves

This is an illustrated cross-section of a typical KITZ split body floating type full bore ball valve to exhibit the basic design concept. The actual design of a valve may be slightly different from this illustration, depending on its sizes and pressure classes.

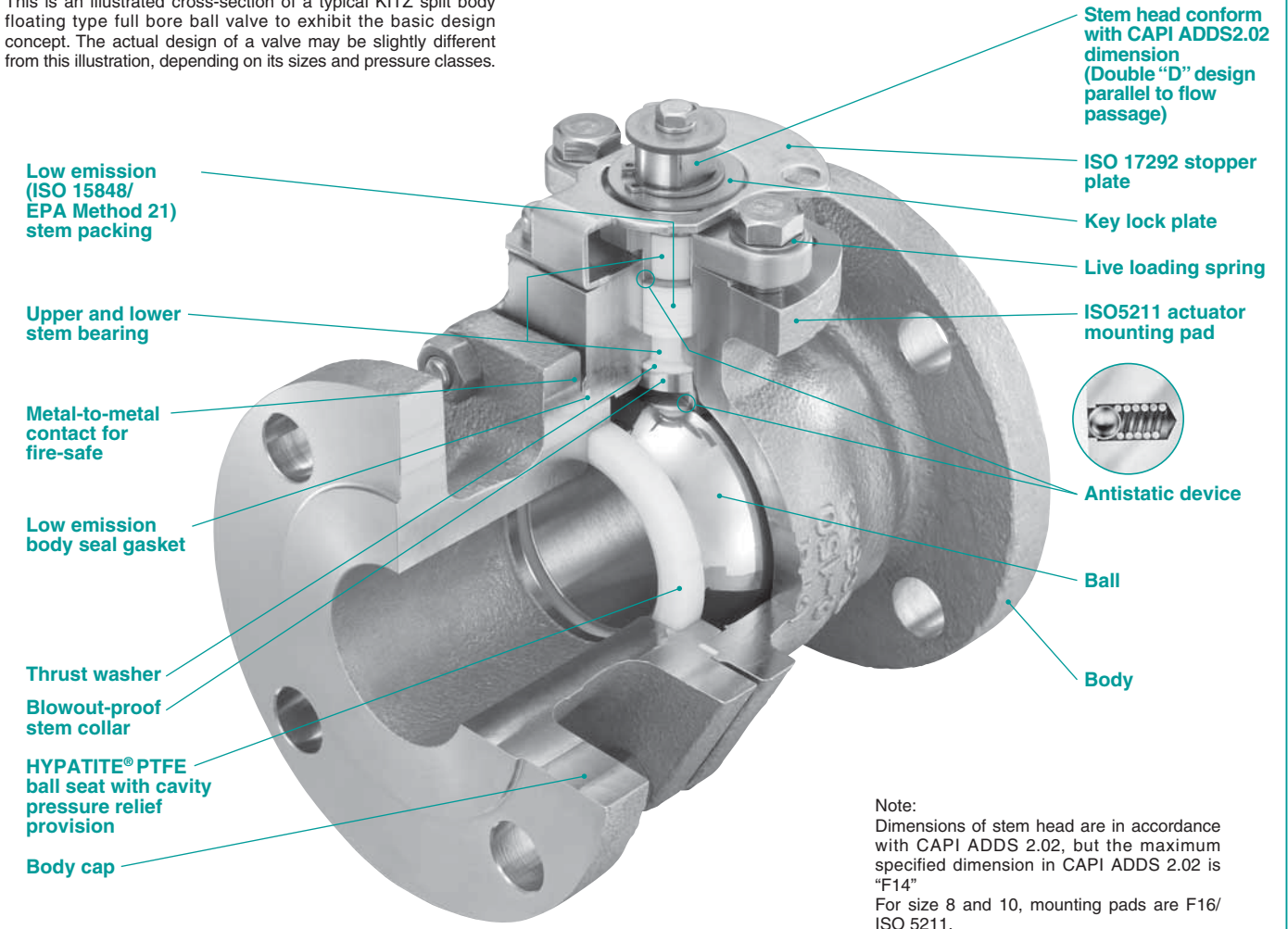

150UTDZ Size 2

### Bubble-tight sealing performance with HYPATITE® PTFE ball seats

HYPATITE® PTFE ball seats, standard stem seals of KITZ ball valves, are made of denatured PTFE, a molecularly reinforced PTFE copolymer, and specifically engineered for high **bidirectional** sealing performance and prolonged service life of valves. Its resistance to high or low temperature, creep or compression, abrasion and corrosion is all outstanding. As an option, KITZ **SWELLESS®** ball seats principally made of PFA are recommended specifically for monomer service. This epoch-making new seat maximizes resistance to the permeation of monomer into its molecular structure (generally known as a “swelling” problem) which causes seat deformation and seriously affects shut-off function of valves in styrene and butadiene monomer service.

### Simplified actuator mounting

For 150/300SCTDZ/UTDZM and SCTAZ/UTAZ(M) Series ball valves, **ISO 5211** actuator mounting pad is integrally provided for uniformly simplified mounting of any actuators provided with valve mounting flanges designed to ISO 5211 dimensional requirement. 150UTBM Series ball valves are provided with KITZ standard integral actuator mounting pad.

### Easy maintenance

Split body design for KITZ SCTDZ/UTDZM Series provides the convenience of very easy maintenance critically required for process plants. In order to provide maintenance to KITZ 150/300SCTAZ/UTAZM, a uni-body side entry floating ball valve, its insert can be removed from the body by unscrewing it.

## KITZ 150/300SCTAZ/UTAZM Series Reduced Bore, Uni-body, End Entry Ball Valves

This is an illustrated cross-section of a typical KITZ uni-body floating type reduced bore ball valve to exhibit the basic design concept. The actual design of a valve may be slightly different from this illustration, depending on its sizes and pressure classes.

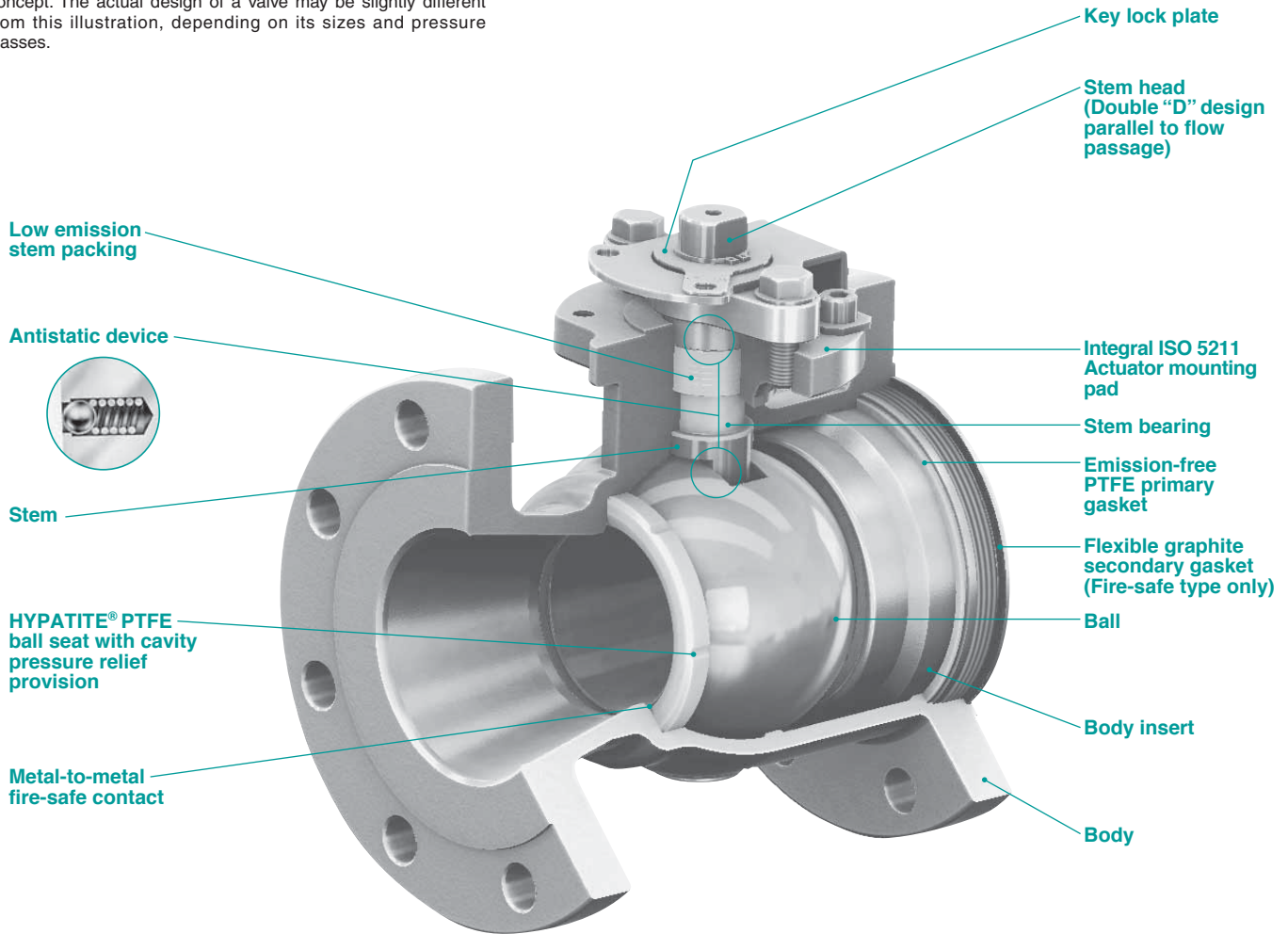

150SCTAZ Size 1 1/2

### Extensive safety considerations

KITZ ball valves are designed with extensive safety considerations for users. Blow-out proof stems, provision of locking devices and prevention of misalignment of lever handles provide safe operation in the field and trouble-free operation in the plant. Antistatic devices, fire-safe design and cavity pressure relief features all assure the economic benefits of smooth, steady plant operation. KITZ advancements in low emission design features contribute to the global battle against fugitive emissions while greatly reducing costs caused by product loss.

### For sour service

Hardness of body, body cap/insert, ball and stem material of KITZ Class 150/300 steel ball valves is controlled by appropriate heat treatment and conformed to the hardness requirements in NACE MR0175, as standard. In addition to the above, following requirements are optionally available.

- Bolting for valves exposed to sour environment.
  - NACE requirements for Class 600 and higher steel ball valves.
- Please contact KITZ for those requirements.

## Seven Safety Considerations for KITZ 150/300SCTDZ/UTDZ(M) 150UTB(M) and 150/300SCTAZ/UTAZ(M) Series Ball Valves

1. **Double “D” stem head design** provides mounting of the lever handle always in parallel to the flow passage. This feature prevents the lever handle from being installed in a wrong orientation. (Fig. 1)
2. The lower end of the stem is designed with an integral collar to be **blowout-proof**. (Fig. 2)
3. An **antistatic feature** is provided to ensure electrical continuity between ball, stem, and body. (Fig. 2)
4. Facility for mounting a **locking device** for prevention of accidental valve operation is provided.
5. **Plant fires** are a serious concern for soft-seated ball valves because of possible fluid leakage by deterioration of resilient sealing materials.

KITZ ball valves are engineered for fire-safety and successfully **fire tested** to minimize both external and internal fluid leakage after plant fires. They have **post-fire metal-to-metal contact** of all sealing areas such as:

- Contact between ball and valve shell (Fig. 3 and 4)
- Contact between stem and valve shell (Fig. 5 and 6)
- Valve shell coupling flanges of split body design (Fig. 7 and 8)
- Contact between valve body and insert of uni-body design (Fig. 9)

The problem of external fluid leakage is more serious than internal leakage through the valve bore because of the fear of fueling the fire. To prevent this, KITZ ball valves may be ordered with **flexible graphite packing** and **gaskets**, which are extremely heat resistant, and not affected by the fire.

6. The surface of stem and stuffing box, and interface clearance of stem-to-gland, stem-to-body and gland-to-stuffing box are precisely controlled on machining and assembly for **low emission service**. A Belleville spring washer is employed for live loading on gland bolts, to minimize need of retightening the bolts for **low emission service**.
7. Some line fluid is usually left trapped inside the ball-body cavity. This fluid can expand under the influence of high ambient or line temperature. An excessive cavity pressure rise may sometimes damage the valve seats or balls, unless the valve has an adequate cavity pressure relief mechanism. **Trunnion mounted ball valves generally provide perfect protection from this problem**. Please contact KITZ Corporation for details.

In case of floating ball valves, however, their rather simple seating principle requires some special protection from excessive cavity pressure rise **when highly volatile liquid in service is subject to frequent and large temperature variation, while the valve is not frequently operated**. KITZ 150/300 SCTDZ/UTDZ(M) and 150/300 SCTAZ/UTAZ(M) Series ball valves offer **self-relieving of excessive cavity pressure** as a standard feature engineered in **HYPATITE® PTFE ball seats**.

Other general solutions for floating ball valves include employment of automatic pressure relief valves or drilling pressure equalization holes on the ball. If the requirement of automatic cavity pressure relief is as critical as in chlorine service, be sure to contact KITZ Corporation or its distributors for technical advice.

This capability is influenced by many variables including: fluid characteristics, variations in pressure, temperature and thermal cycles.

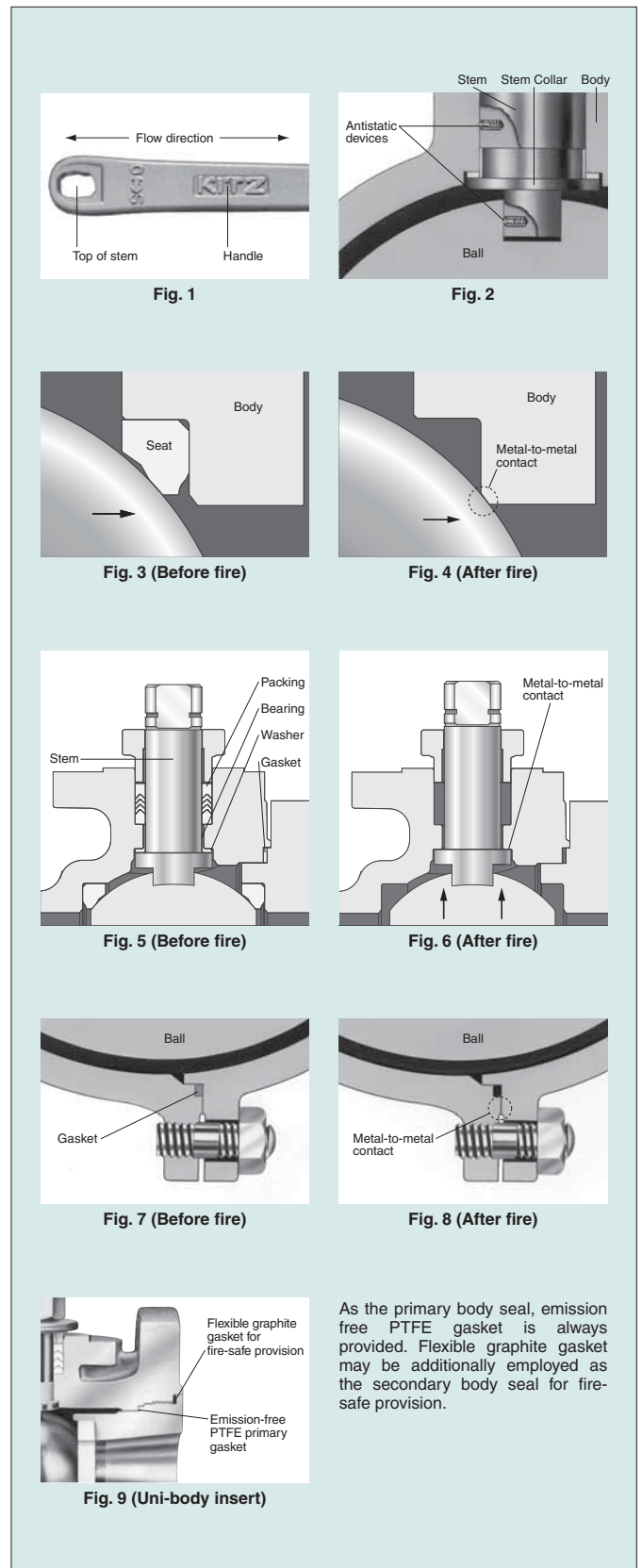



# Class 150 Stainless Steel Ball Valves

## Full bore, Split body, Side entry design

### Features

- Antistatic device
- Blowout-proof stem
- Double "D" stem head
- High performance **HYPATITE® PTFE** ball seats

Page 99 for Pressure-Temperature Ratings.

Page 44 for Construction and Materials.

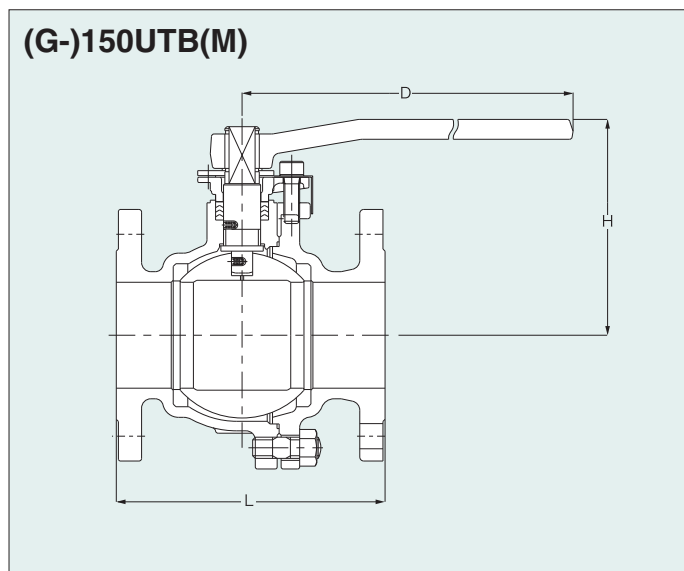

### Dimensions of 150UTB(M)

Unit: mm

Nominal Size	NPS	1/2	3/4	1	1 1/2	2	2 1/2	3	4	5	6	8	10
	DN	15	20	25	40	50	65	80	100	125	150	200	250
Ball bore		15	20	25	40	50	65	80	100	125	150	200	250
L		108	117	127	165	178	190	203	229	356	394	457	533
H		102	105	124	115	120	155	165	200	220	295	355	Gear operation
D		130	130	160	230	230	400	400	460	460	1000	1500	Gear operation

### Valve operator

NPS 1/2 to 8: Lever operation  
 NPS 5 to 8: Optional gear operation  
 NPS 10: Standard gear operation

### Gear Operation

Unit: mm

Nominal Pressure	Class 150	Gear Operator			
		H	D	C	A
Nominal size (NPS)	5	312	310	165	65.5
	6	337	310	165	65.5
	8	414	360	210	88.5
	10	477	500	363	93.5

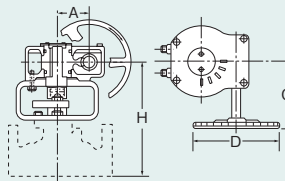

Worm gear operators may be mounted on KITZ ball valves at your option for the smoothest valve operation. Electric or pneumatic actuators are also optionally available. Contact KITZ distributors for appropriate choice and sizing of valve actuators.

Refer to "Product Range" on Page 1.

# Class 600/1500 Stainless Steel/Carbon Steel Ball Valves

## Full bore, Split body, Side entry design

### Features

- Antistatic device
- Blowout-proof stem
- Fire test certification★ (API 607) ...Carbon Steel only
- Double "D" stem head
- Ball seats: Reinforced PTFE with MoS<sub>2</sub> for Class 600  
Nylon with MoS<sub>2</sub> for Class 1500

Page 100 for Pressure-Temperature Ratings.

Page 46 to 49 for Construction and Materials.

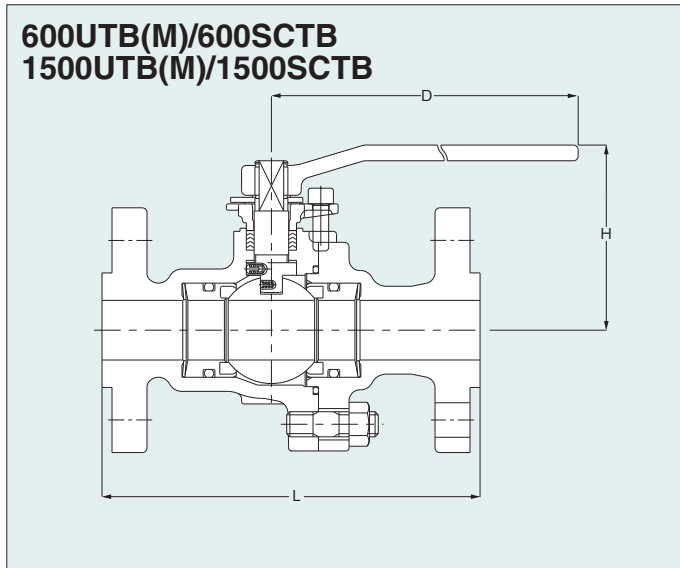

### Dimensions of 600UTB(M), 600SCTB

Unit: mm

Nominal Size	NPS	1/2	3/4	1	1 1/2
	DN	15	20	25	40
Ball bore		13	19	25	38
L		165	190	216	241
H		105	108	130	118
D		130	130	160	230

### Valve operator

Lever operation

### Options

- ★ Flexible graphite packing and flexible graphite spiral wound gasket (See Pages 11, 46 and 47)
- Ball and stem to 316ss available in carbon steel valves upon request

### Dimensions of 1500UTB(M), 1500SCTB

Unit: mm

Nominal Size	NPS	1/2	3/4	1	1 1/2
	DN	15	20	25	40
Ball bore		13	19	25	38
L		216	229	254	305
H		134	117	123	148
D		160	230	230	400

### Valve operator

Lever operation

### Options

- ★ Flexible graphite packing and flexible graphite spiral wound gasket (See Pages 11, 48 and 49)
- Ball and stem to 316ss available in carbon steel valves upon request

# Class 150/300 Stainless Steel/Carbon Steel Ball Valves

## Full bore, Split body, Side entry design

### Features

- Antistatic device
- Blowout-proof stem
- Fire test certification★(API 607, ISO 10497)
- Stem head conform to CAPI ADDS 2.02 dimensions
- High performance **HYPATITE® PTFE** ball seats
- Actuator mounting pad to ISO 5211
- Conform to NACE MR0175 for hardness of body, body cap, stem and ball.

Page 96 for Pressure-Temperature Ratings.

Page 43 for Construction and Materials.

Page 93 for Dimension of Actuator Mounting Pad.

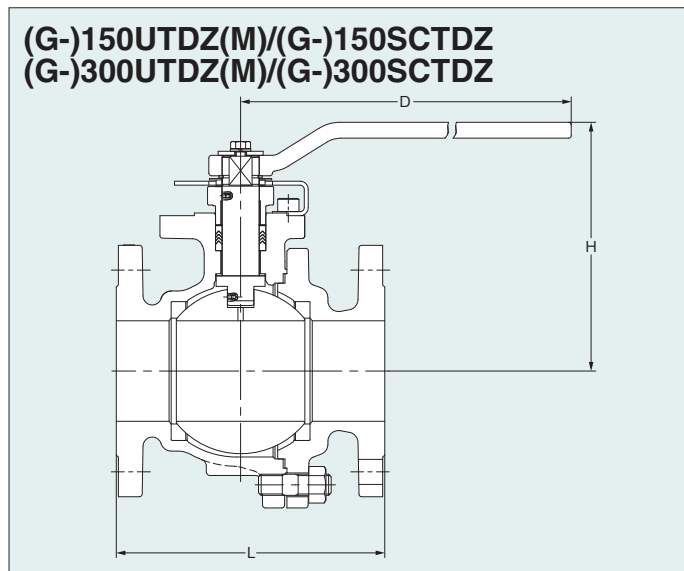

**(G-)150UTDZ(M)/(G-)150SCTDZ**  
**(G-)300UTDZ(M)/(G-)300SCTDZ**

### Dimensions of 150UTDZ(M), 150SCTDZ

Unit: mm

Nominal Size	NPS	1/2	3/4	1	1 1/4*	1 1/2	2	2 1/2	3	4	5	6	8	10
	DN	15	20	25	32*	40	50	65	80	100	125	150	200	250
Ball bore		14	19	24	32	38	50	64	76	100	123	151	202	253
L		108	117	127	140	165	178	190	203	229	356	394	457	533
H		108	111	124	128	134	143	179	189	224	240	315	406	Gear operation
D		130	130	160	160	230	230	400	400	460	460	1000	1500	Gear operation

### Valve operator

NPS 1/2 to 8: Lever operation  
 NPS 5 to 8: Optional gear operation  
 NPS 10: Standard gear operation

### Option

- ★ Flexible graphite packing and gasket (See Pages 11 and 43)
- Ball and stem to 316ss available in carbon steel valves upon request

### Dimensions of 300UTDZ(M), 300SCTDZ

Unit: mm

Nominal Size	NPS	1/2	3/4	1	1 1/4*	1 1/2	2	2 1/2	3	4	5	6	8
	DN	15	20	25	32*	40	50	65	80	100	125	105	200
Ball bore		14	19	24	32	38	50	64	76	100	123	151	202
L		140	152	165	178	190	216	241	283	305	381	403	502
H		108	111	124	128	134	143	179	189	251	267	315	406
D		130	130	160	160	230	230	400	400	750	750	1000	1500

### Valve operator

NPS 1/2 to 8: Lever operation  
 NPS 6 to 8: Optional gear operation

### Option

- ★ Flexible graphite packing and gasket (See Pages 11 and 43)
- Ball and stem to 316ss available in carbon steel valves upon request

### Gear Operation

Unit: mm

Nominal Pressure	Class 150	Class 300	Gear Operator										
			H		D		C		A				
			150	300	150	300	150	300	150	300			
		4	258	310	165	65.5							
Nominal size (NPS)	5		274	254	165	65.5							
	6	6	322	335	310	360	165	210	66.5	88.5			
	8	8	412	412	360	360	210	210	88.5	88.5			
	10		448	—	500	—	363	—	93.5	—			

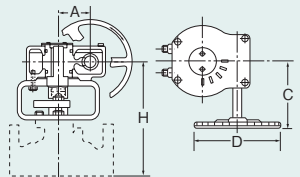

Worm gear operators may be mounted on KITZ ball valves at your option for the smoothest valve operation. Electric or pneumatic actuators are also optionally available. Contact KITZ distributors for appropriate choice and sizing of valve actuators.

Refer to "Product Range" on Page 1.

# Class 150/300 Stainless Steel/Carbon Steel Ball Valves

## Full bore, Split body, Side entry design

### Features

- FILLTITE® ball seats. Temperature range: -29°C to 300°C
- Antistatic device
- Blowout-proof stem
- Fire test certification (API 607, ISO 10497)
- Stem head conform to CAPI ADDS2.02 dimensions
- Actuator mounting pad to ISO 5211
- Conform to NACE MR0175 for hardness of body, body cap, stem and ball

Page 97 for Pressure-Temperature Ratings.

Page 37 for Construction and Materials.

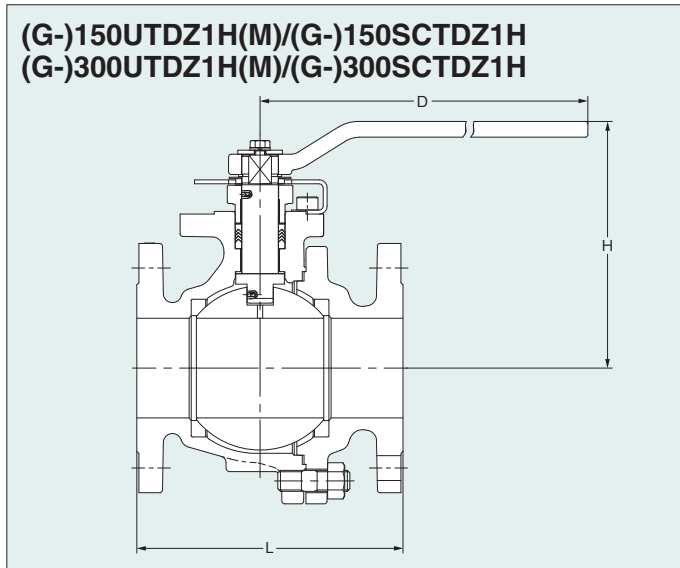

### Dimensions of 150UTDZ1H(M), 150SCTDZ1H

Unit: mm

Nominal Size	NPS	1/2	3/4	1	1 1/4	1 1/2	2	2 1/2	3	4	5	6	8	10
	DN	15	20	25	32	40	50	65	80	100	125	150	200	250
Ball bore		14	19	24	32	38	50	64	76	100	123	151	202	253
L		108	117	127	140	165	178	190	203	229	356	394	457	533
H		108	111	124	128	134	143	179	189	251	Gear operation	Gear operation	Gear operation	Gear operation
D		130	130	160	160	230	230	400	400	750	Gear operation	Gear operation	Gear operation	Gear operation

### Valve operator

NPS 1/2 to 4: Lever operation  
NPS 5 to 10: Standard gear operation

### Dimensions of 300UTDZ1H(M), 300SCTDZ1H

Unit: mm

Nominal Size	NPS	1/2	3/4	1	1 1/2	2	2 1/2	3	4	6	8
	DN	15	20	25	40	50	65	80	100	150	200
Ball bore		14	19	24	38	50	64	76	100	151	202
L		140	152	165	190	216	241	283	305	403	502
H		108	111	124	134	143	179	189	Gear operation	Gear operation	Gear operation
D		130	130	160	230	230	400	400	Gear operation	Gear operation	Gear operation

### Valve operator

NPS 1/2 to 3: Lever operation  
NPS 4 to 8: Standard gear operation

### Options

- Ball and stem to 316ss available in carbon steel valves upon request

### Gear Operation

Unit: mm

Nominal Pressure	Class 150	Class 300	Gear Operator							
			H		D		C		A	
			150	300	150	300	150	300	150	300
Valve size (NPS)	4		274	258	310	310	165	165	65.5	65.5
	5	4	274	258	310	310	165	165	65.5	65.5
	6	6	335	332	360	500	210	363	88.5	93.5
	8	8	409	417	500	500	363	377	93.5	134.0
	10		456		500		377		134.0	

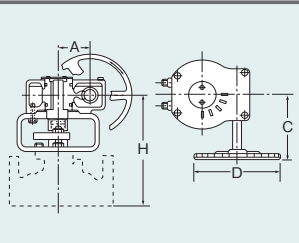

Electric or pneumatic actuators are also optionally available. Contact KITZ distributors for appropriate choice and sizing of valve actuators.

Refer to "Product Range" on Page 4.

# Hard Graphite Seated Floating Ball Valve (Trim 3H)

**(G-)150/10UTDZ3H(M)**  
**(G-)150/10SCTDZ3H**

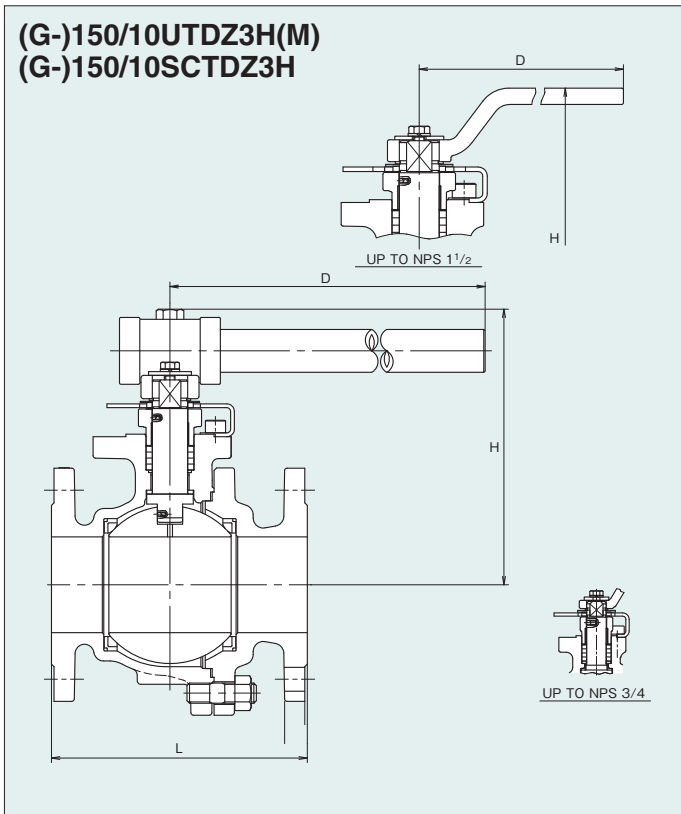

Page 97 for Pressure-Temperature Ratings.  
Page 39 for Construction and Materials.

## Dimensions of 150UTDZ3H(M), 150SCTDZ3H

Unit: mm

Nominal Size	NPS	1/2	3/4	1	1 1/4*	1 1/2	2	2 1/2	3	4	5	6	8
	DN	15	20	25	32	40	50	65	80	100	125	150	200
L		108	117	127	140	165	178	190	203	229	356	394	457
H		108	111	124	128	134	148	209	219	251	Gear operation	Gear operation	Gear operation
D		130	130	160	160	230	300	600	600	1000	Gear operation	Gear operation	Gear operation

\* 150UTDZ3H only.

## Dimensions of 10UTDZ3H(M), 10SCTDZ3H

Unit: mm

Nominal Size	NPS	1/2	3/4	1	1 1/4*	1 1/2	2	2 1/2	3	4	5	6	8
	DN	15	20	25	32	40	50	65	80	100	125	150	200
L		108	117	127	140	165	178	190	203	229	356	394	457
H		108	111	124	128	134	148	209	219	251	Gear operation	Gear operation	Gear operation
D		130	130	160	160	230	300	600	600	1000	Gear operation	Gear operation	Gear operation

\* 10UTDZ3H only.

## Gear Operation

Unit: mm

Nominal Pressure	Class	10K	Gear Operator			
			H	D	C	A
Nominal size (NPS)	5	5	247	310	165	66.5
	6	6	335	360	210	88.5
	8	8	417	500	377	134.0

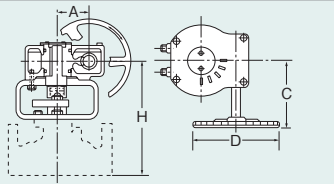

## Valve operator

NPS 1/2 to 4: Lever operation  
NPS 5 to 8: Standard gear operation

Worm gear operators may be mounted on KITZ ball valves at your option for the smoothest valve operation. Electric or pneumatic actuators are also optionally available. Contact KITZ distributors for appropriate choice and sizing of valve actuators.

Refer to "Product Range" on Page 5.



# Hard Graphite Seated Floating Ball Valve (Trim 3H)

(G-)300/20UTDZ3H(M)  
(G-)300/20SCTDZ3H

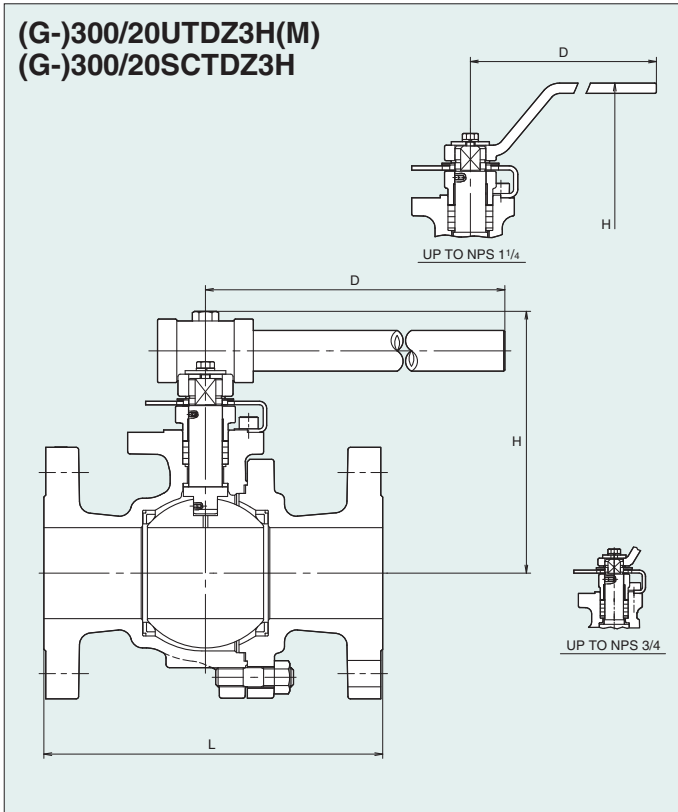

Page 97 for Pressure-Temperature Ratings.  
Page 39 for Construction and Materials.

## Dimensions of 300UTDZ3H(M), 300SCTDZ3H

Unit: mm

Nominal Size	NPS	1/2	3/4	1	1 1/4*	1 1/2	2	2 1/2	3	4	5	6	8
	DM	15	20	25	32	40	50	65	80	100	125	150	200
L		140	152	165	178	190	216	241	283	305	381	403	502
H		108	111	124	128	139	148	209	219	Gear operation	Gear operation	Gear operation	Gear operation
D		130	130	160	160	600	600	1000	1000	Gear operation	Gear operation	Gear operation	Gear operation

\* 300UTDZ3H only.

## Valve operator

NPS 1/2 to 3: Lever operation  
NPS 4 to 8: Standard gear operation

## Dimensions of 20UTDZ3H(M), 20SCTDZ3H

Unit: mm

Nominal Size	NPS	1/2	3/4	1	1 1/4*	1 1/2	2	2 1/2	3	4	5	6	8
	DM	15	20	25	32	40	50	65	80	100	125	150	200
L		140	152	165	178	190	216	241	283	305	381	403	502
H		108	111	124	128	139	148	209	219	Gear operation	Gear operation	Gear operation	Gear operation
D		130	130	160	160	600	600	1000	1000	Gear operation	Gear operation	Gear operation	Gear operation

\* 20UTDZ3H only.

## Gear Operation

Unit: mm

Nominal Pressure	Class	20K	Gear Operator			
			H	D	C	A
Valve size (NPS)	4	4	286	360	210	88.5
	5	5	302	360	210	88.5
	6	6	360	500	377	134.0
	8	8	489	500	377	213.0

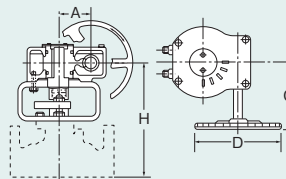

Worm gear operators may be mounted on KITZ ball valves at your option for the smoothest valve operation. Electric or pneumatic actuators are also optionally available. Contact KITZ distributors for appropriate choice and sizing of valve actuators.

Refer to "Product Range" on Page 5.

# Metal Seated Floating Ball Valve (Trim 5H)

(G-)150/10UTDZ5H(M)  
(G-)150/10SCTDZ5H

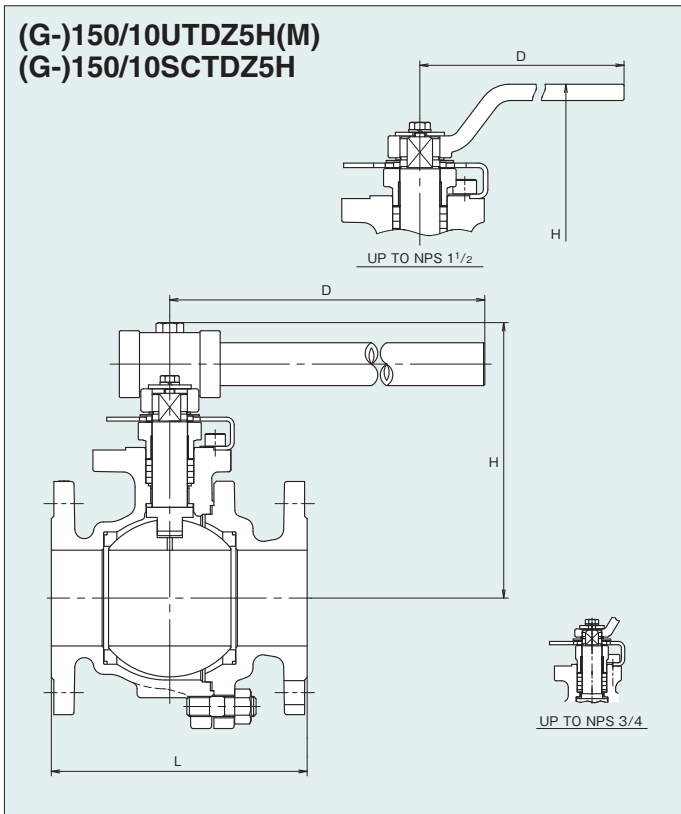

Page 98 for Pressure-Temperature Ratings.

Page 40 for Construction and Materials.

## Dimensions of 150UTDZ5H(M), 150SCTDZ5H

Unit: mm

Nominal Size	NPS	1/2	3/4	1	1 1/4*	1 1/2	2	2 1/2	3	4	5	6	8
	DM	15	20	25	32	40	50	65	80	100	125	150	200
L		108	117	127	140	165	178	190	203	229	356	394	457
H		108	111	124	128	134	148	209	219	251	Gear operation	Gear operation	Gear operation
D		130	130	160	160	230	300	600	600	1000	Gear operation	Gear operation	Gear operation

\* 150UTDZ5H only.

## Dimensions of 10UTDZ5H(M), 10SCTDZ5H

Unit: mm

Nominal Size	NPS	1/2	3/4	1	1 1/4*	1 1/2	2	2 1/2	3	4	5	6	8
	DM	15	20	25	32	40	50	65	80	100	125	150	200
L		108	117	127	140	165	178	190	203	229	356	394	457
H		108	111	124	128	134	148	209	219	251	Gear operation	Gear operation	Gear operation
D		130	130	160	160	230	300	600	600	1000	Gear operation	Gear operation	Gear operation

\* 10UTDZ5H only.

## Gear Operation

Unit: mm

Nominal Pressure	Class 150	10K	Gear Operator			
			H	D	C	A
Nominal size (NPS)	5	5	302	360	210	88.5
	6	6	335	360	210	88.5
	8	8	417	500	377	134.0

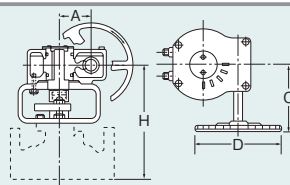

## Valve operator

NPS 1/2 to 4: Lever operation

NPS 5 to 8: Standard gear operation

Worm gear operators may be mounted on KITZ ball valves at your option for the smoothest valve operation. Electric or pneumatic actuators are also optionally available. Contact KITZ distributors for appropriate choice and sizing of valve actuators.

# Metal Seated Floating Ball Valve (Trim 5H)

**(G-)300/20UTDZ5H(M)**  
**(G-)300/20SCTDZ5H**

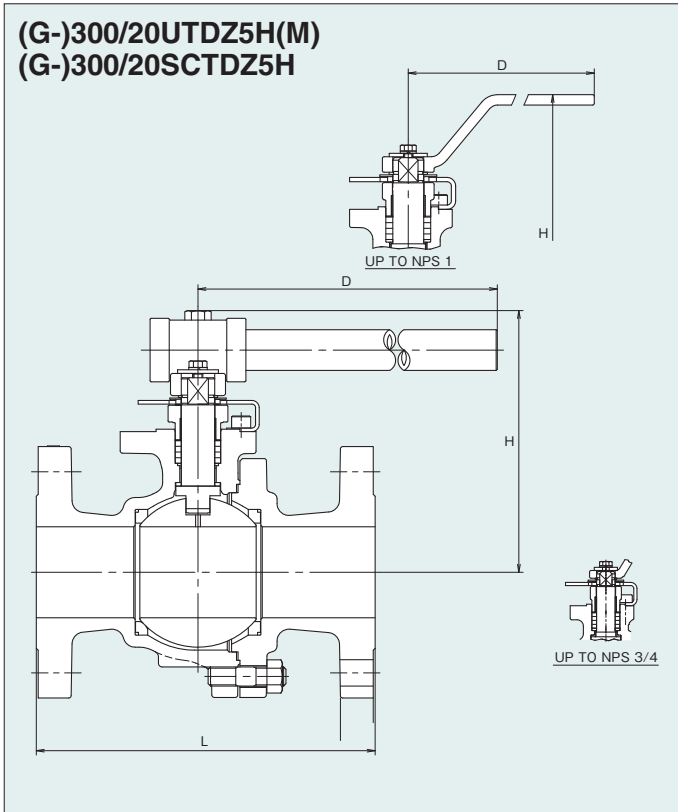

Page 98 for Pressure-Temperature Ratings.  
 Page 40 for Construction and Materials.

## Dimensions of 300UTDZ5H(M), 300SCTDZ5H

Unit: mm

Nominal Size	NPS	1/2	3/4	1	1 1/4	1 1/2	2	2 1/2	3	4	5	6	8
	DN	15	20	25	32	40	50	65	80	100	125	150	200
L		140	152	165	178	190	216	241	283	305	381	403	502
H		108	111	124	128	139	148	209	219	Gear operation	Gear operation	Gear operation	Gear operation
D		130	130	160	160	600	600	1000	1000	Gear operation	Gear operation	Gear operation	Gear operation

### Valve operator

NPS 1/2 to 3: Lever operation  
 NPS 4 to 8: Standard gear operation

## Dimensions of 20UTDZ5H(M), 20SCTDZ5H

Unit: mm

Nominal Size	NPS	1/2	3/4	1	1 1/4	1 1/2	2	2 1/2	3	4	5	6	8
	DN	15	20	25	32	40	50	65	80	100	125	150	200
L		140	152	165	178	190	216	241	283	305	381	403	502
H		108	111	124	128	139	148	209	219	Gear operation	Gear operation	Gear operation	Gear operation
D		130	130	160	160	600	600	1000	1000	Gear operation	Gear operation	Gear operation	Gear operation

## Gear Operation

Unit: mm

Nominal Pressure	Class	20K	Gear Operator			
			H	D	C	A
Nominal size (NPS)	4	4	286	360	210	88.5
	5	5	299	500	363	93.5
	6	6	360	500	377	134.0
	8	8	489	500	377	213.0

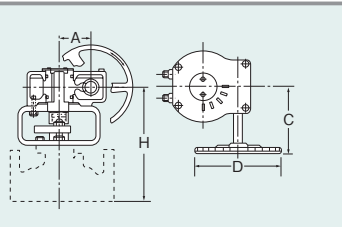

Worm gear operators may be mounted on KITZ ball valves at your option for the smoothest valve operation. Electric or pneumatic actuators are also optionally available. Contact KITZ distributors for appropriate choice and sizing of valve actuators.

Refer to "Product Range" on Page 5.

# Metal Seated Floating Ball Valve (Trim 6H)

**(G-)150/10UTDZ6H(M)**  
**(G-)150/10SCTDZ6H**

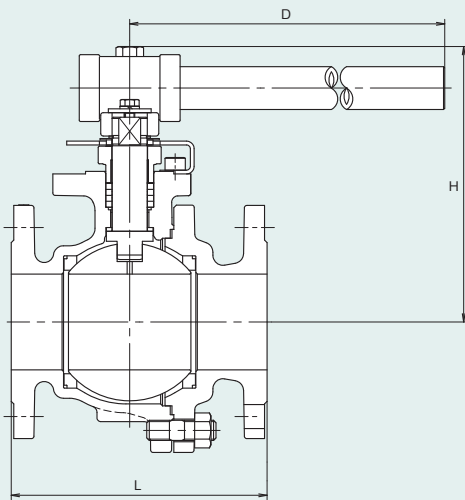
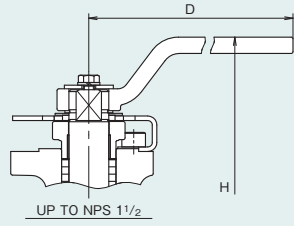

Page 98 for Pressure-Temperature Ratings.

Page 41 for Construction and Materials.

### Dimensions of 150UTDZ6H(M), 150SCTDZ6H

Unit: mm

Nominal Size	NPS	1/2	3/4	1	1 1/4*	1 1/2	2	2 1/2	3	4	5	6	8
	DN	15	20	25	32	40	50	65	80	100	125	150	200
L		108	117	127	140	165	178	190	203	229	356	394	457
H		108	111	124	128	134	148	209	219	251	Gear operation	Gear operation	Gear operation
D		130	130	160	160	230	300	600	600	1000	Gear operation	Gear operation	Gear operation

\* 150UTDZ6H only.

### Dimensions of 10UTDZ6H(M), 10SCTDZ6H

Unit: mm

Nominal Size	NPS	1/2	3/4	1	1 1/4*	1 1/2	2	2 1/2	3	4	5	6	8
	DN	15	20	25	32	40	50	65	80	100	125	150	200
L		108	117	127	140	165	178	190	203	229	356	394	457
H		108	111	124	128	134	148	209	219	251	Gear operation	Gear operation	Gear operation
D		130	130	160	160	230	300	600	600	1000	Gear operation	Gear operation	Gear operation

\* 10UTDZ6H only.

### Gear Operation

Unit: mm

Nominal Pressure	Class 150	10K	Gear Operator			
			H	D	C	A
Nominal size (NPS)	5	5	302	360	210	88.5
	6	6	335	360	210	88.5
	8	8	417	500	377	134.0

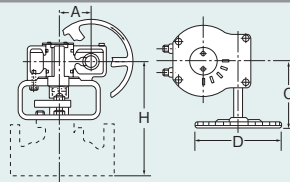

### Valve operator

NPS 1/2 to 4: Lever operation  
 NPS 5 to 8: Standard gear operation

Worm gear operators may be mounted on KITZ ball valves at your option for the smoothest valve operation. Electric or pneumatic actuators are also optionally available. Contact KITZ distributors for appropriate choice and sizing of valve actuators.

# Metal Seated Floating Ball Valve (Trim 6H)

(G-)300/20UTDZ6H(M)  
(G-)300/20SCTDZ6H

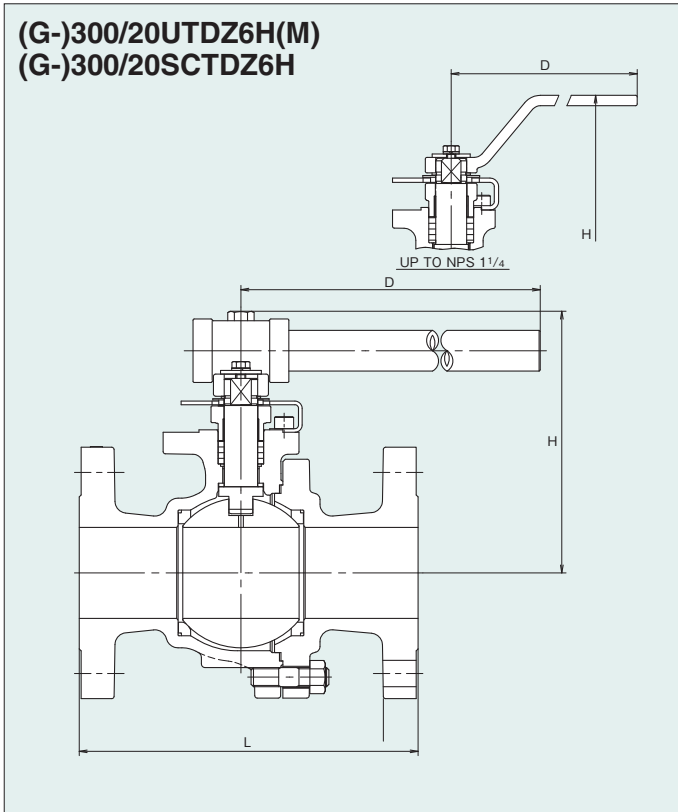

Page 98 for Pressure-Temperature Ratings.  
Page 41 for Construction and Materials.

## Dimensions of 300UTDZ6H(M), 300SCTDZ6H

Unit: mm

Nominal Size	NPS	1/2	3/4	1	1 1/4*	1 1/2	2	2 1/2	3	4	5	6	8
	DN	15	20	25	32	40	50	65	80	100	125	150	200
L		140	152	165	178	190	216	241	283	305	381	403	502
H		108	111	124	128	139	148	209	219	Gear operation	Gear operation	Gear operation	Gear operation
D		130	130	160	160	600	600	1000	1000	Gear operation	Gear operation	Gear operation	Gear operation

\* 300UTDZ6H only.

## Valve operator

NPS 1/2 to 3: Lever operation  
NPS 4 to 8: Standard gear operation

## Dimensions of 20UTDZ6H(M), 20SCTDZ6H

Unit: mm

Nominal Size	NPS	1/2	3/4	1	1 1/4*	1 1/2	2	2 1/2	3	4	5	6	8
	DN	15	20	25	32	40	50	65	80	100	125	150	200
L		140	152	165	178	190	216	241	283	305	381	403	502
H		108	111	124	128	139	148	209	219	Gear operation	Gear operation	Gear operation	Gear operation
D		130	130	160	160	600	600	1000	1000	Gear operation	Gear operation	Gear operation	Gear operation

\* 20UTDZ6H only.

## Gear Operation

Unit: mm

Nominal Pressure	Class 300	20K	Gear Operator			
			H	D	C	A
Nominal size (NPS)	4	4	286	360	210	88.5
	5	5	299	500	363	93.5
	6	6	360	500	377	134.0
	8	8	489	500	377	213.0

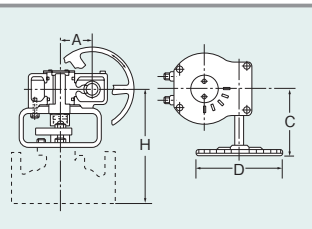

Worm gear operators may be mounted on KITZ ball valves at your option for the smoothest valve operation. Electric or pneumatic actuators are also optionally available. Contact KITZ distributors for appropriate choice and sizing of valve actuators.

Refer to "Product Range" on Page 6.



## Class 150 Stainless Steel Pocketless Ball Valves

### Full bore, Split body, Side entry design

Page 99 for Pressure-Temperature Ratings.

#### Features

- Unique filled cavity provides excellent resistance to media build up and/or stagnation between seats
- Antistatic device
- Blowout-proof stem
- Double "D" stem head
- High performance **HYPATITE®** PTFE ball seats
- Actuator mounting pad to KITZ standard

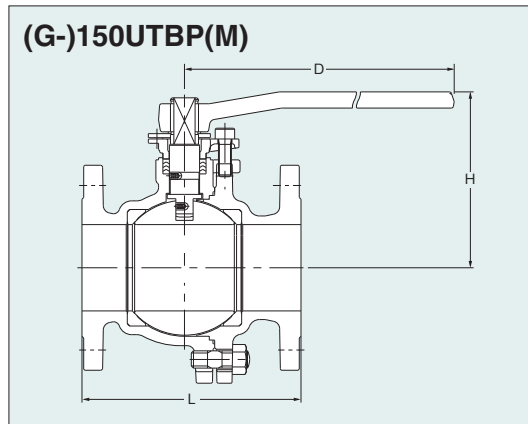

#### Valve operator

NPS 1/2 to 8: Lever operation  
NPS 5 to 8: Optional gear operation

#### Dimensions of 150UTBP(M)

Unit: mm

Nominal Size	NPS	1/2	3/4	1	1 1/2	2	2 1/2	3	4	5	6	8
	DN	15	20	25	40	50	65	80	100	125	150	200
Ball bore		15	20	25	40	50	65	80	100	125	150	200
L		108	117	127	165	178	190	203	229	356	394	457
H		102	105	124	115	120	155	165	200	220	295	355
D		130	130	160	230	230	400	400	460	460	1000	1500

※Please contact KITZ or KITZ distributors for details about gear operated products.

## Class 150 Stainless Steel Jacketed Ball Valves

### Full bore

Page 99 for Pressure-Temperature Ratings.

#### Features

- Fully jacketed to maintain media temperature
- Antistatic device
- Double "D" stem head
- High performance **HYPATITE®** PTFE ball seats
- Actuator mounting pad to KITZ standard

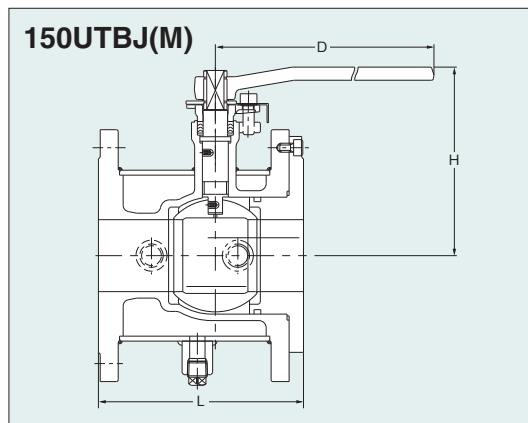

#### Valve operator

NPS 1/2 to 6: Lever operation  
NPS 6: Optional gear operation

#### Note

- Maximum allowable pressure is 1.4 MPa (200 psi) at 260°C (500°F).
- 10K type is also available.

#### Dimensions of 150UTBJ(M)

Unit: mm

Nominal Size	NPS	1/2	3/4	1	1 1/2	2	2 1/2	3*	4*	6*
	DN	15	20	25	40	50	65	80	100	150
Ball bore		15	20	25	40	50	65	65	80	125
L		110	120	130	165	180	190	200	230	270
H		131	135	150	150	157	188	188	213	258
D		130	130	160	230	230	400	400	400	460

\* 150UTRJM

# Class 150 Stainless Steel 3-way Ball Valves

## Full bore, 2-seated or 4-seated, Split body, Side entry design

### Features

- Used for diverting or mixing process media
- One 3-way valve can replace several other valves plus the associated piping pieces
- Antistatic device
- Blowout-proof stem
- Double "D" stem head
- High performance **HYPATITE® PTFE** ball seats
- Actuator mounting pad to KITZ standard

150UTB2L/2T: Page 96 for Pressure-Temperature Ratings. (See UTDZ Series)

150UTB4LA/4TA: Page 100 for Pressure-Temperature Ratings.

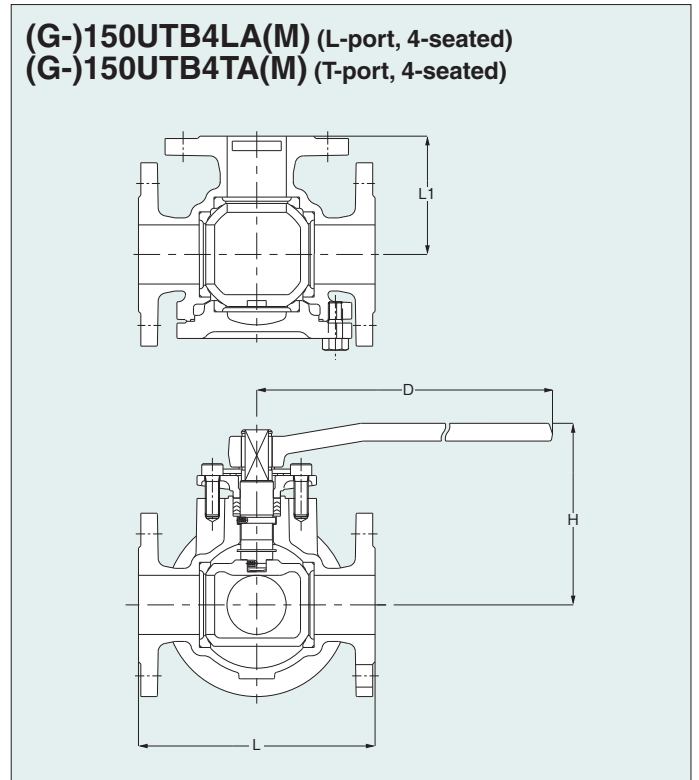
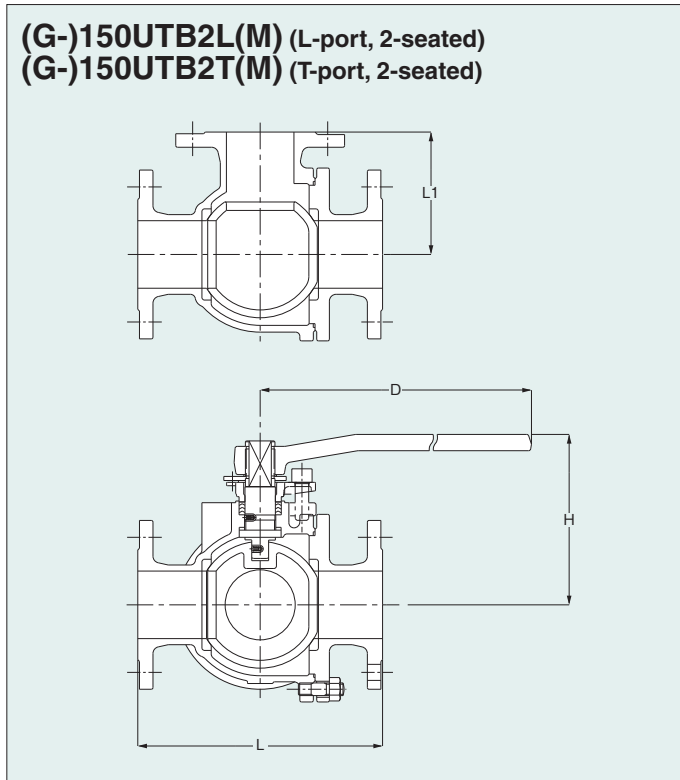

### Dimensions of 150UTB2L(M), 150UTB2T(M)

Unit: mm

Nominal Size	NPS	1	1½	2	2½	3	4	6*
	DN	25	40	50	65	80	100	150
Ball bore		25	38	51	65	76	102	127
L		165	210	220	250	262	342	437
L1		82.5	105	110	125	131	171	218.5
H		124	115	123	155	165	200	220
D		160	230	230	400	400	460	460

### Valve operator

NPS 1 to 6: Lever operation  
 NPS 6: Optional gear operation

### Note

· 10K type is also available.

### Dimensions of 150UTB4LA(M), 150UTB4TA(M)

Unit: mm

Nominal Size	NPS	½	¾	1	1½	2	2½	3	4
	DN	15	20	25	40	50	65	80	100
Ball bore		15	19	25	38	51	64	76	102
L		120	135	154	177	200	240	262	342
L1		65	67.5	77	88.5	100	120	131	171
H		128	132	135	146	155	185	198	267
D		160	160	160	400	400	460	460	1000

### Valve operator

NPS ½ to 8: Lever operation  
 NPS 5 to 8: Optional gear operation

### Note

· 10K type is also available.

Refer to "Product Range" on Page 2.

### Gear Operation

Unit: mm

Nominal Pressure	Class 150	Gear Operator			
		H	D	C	A
	6	399	360	210	88.5
8	467	500	363	93.5	

# Class 150 Stainless Steel 3-way Ball Valves

## Reduced bore, 2-seated or 4-seated, Split body, Side entry design

### Features

- Used for diverting or mixing process media
- One 3-way valve can replace several other valves plus the associated piping pieces
- Antistatic device
- Blowout-proof stem
- Double "D" stem head
- High performance **HYPATITE® PTFE** ball seats
- Actuator mounting pad to KITZ standard

150UTR2L/2T: Page 96 for Pressure-Temperature Ratings. (See UTDZ Series)

150UTR4LA/4TA: Page 100 for Pressure-Temperature Ratings.

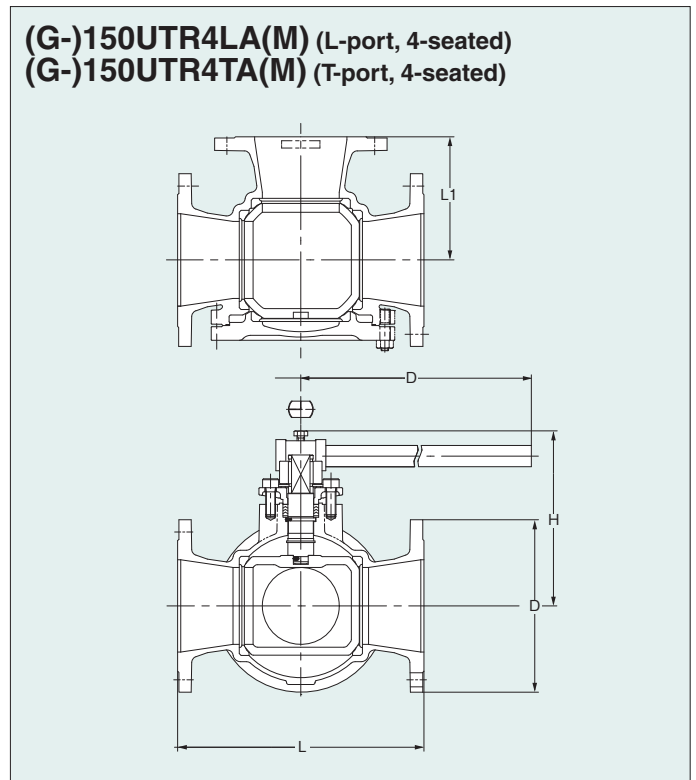
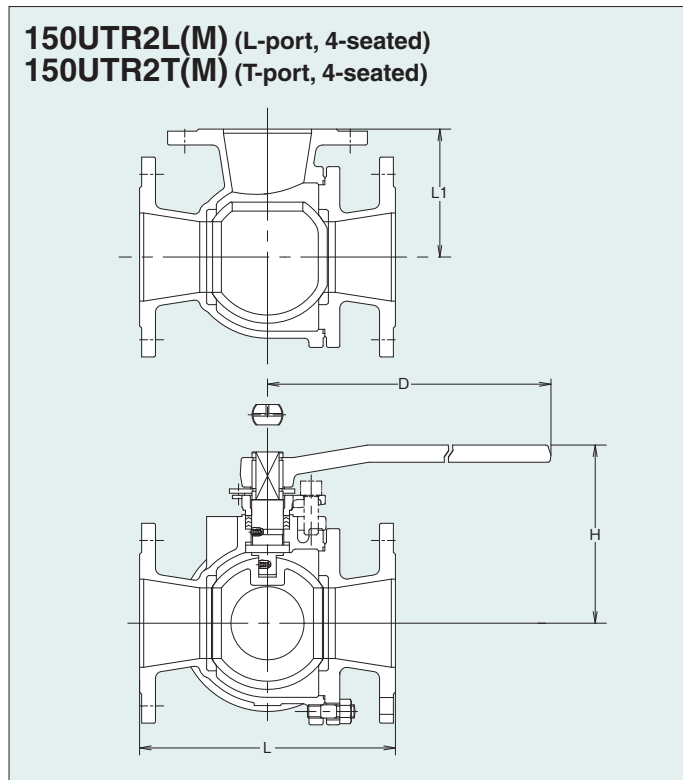

### Dimensions of 150UTR2L(M), 150UTR2T(M)

Unit: mm

Nominal Size	NPS	6
	DN	150
Ball bore		127
L		437
L1		218.5
H		220
D		460

### Valve operator

NPS 1 to 6: Lever operation  
 NPS 6: Optional gear operation

### Note

·10K type is also available.

### Dimensions of 150UTR4LA(M), 150UTR4TA(M)

Unit: mm

Nominal Size	NPS	5	6	8
	DN	125	150	200
Ball bore		100	125	150
L		348	407	463
L1		174	203.5	231.5
H		267	289	335
D		1000	1000	1500

### Valve operator

NPS 5 to 8: Lever operation  
 NPS 5 to 8: Optional gear operation

### Note

·10K type is also available.

Refer to "Product Range" on Page 2.

※Please contact KITZ or KITZ distributors for details about gear operated products.

## Class 150 Stainless Steel Tank Ball Valves

### Full bore, Split body, Side entry design

Page 99 for Pressure-Temperature Ratings.

#### Features

- Direct mounting to tank bottom
- Churning media evenly
- Antistatic device
- Blowout-proof stem
- Double "D" stem head
- High performance **HYPATITE®** PTFE ball seats
- Actuator mounting pad to KITZ standard

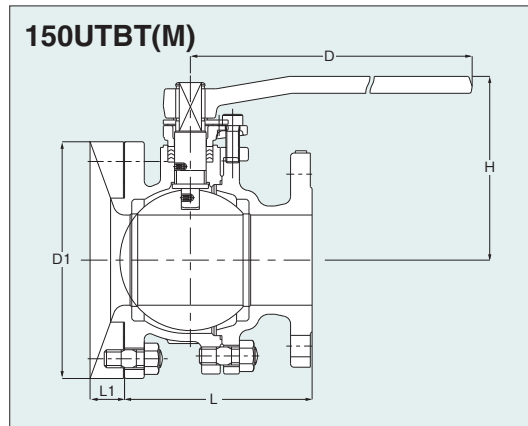

#### Valve operator

NPS 1 to 6: Lever operation

#### Note

- Maximum allowable temperature is 200°C (392°F).
- Class 300 and 10K/20K types are also available.

#### Dimensions of 150UTBT(M)

Unit: mm

Nominal Size	NPS DN	1	1½	2	2½	3	4	5	6	8	10
		25	40	50	65	80	100	125	150	200	250
Ball bore		25	40	50	65	80	100	125	150	For these sizes, please contact KITZ Corporation.	
L		102	125	142	160	171	176	255	292		
H		150	134	143	177	187	222	242	312		
D		160	230	230	400	400	460	460	1000		
L1		35	35	41	43	45	53	53	53		
D1		135	155	175	185	210	280	305	330		

## 10K Stainless Steel PFA Lined Ball Valves

### Full bore, Split body, Side entry design

Page 100 for Pressure-Temperature Ratings.

#### Features

- Highly corrosion-resistant PFA lining
- Fine lining without a pinhole
- Highly heat-resistant PFA
- No additives or paints are included
- Double "D" stem head
- High performance **HYPATITE®** PTFE ball seats
- Actuator mounting pad to KITZ standard

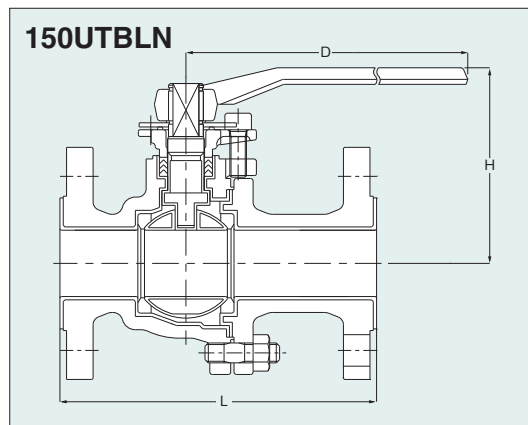

#### Valve operator

NPS ½ to 4: Lever operation

#### Dimensions of 150UTBLN

Unit: mm

Nominal Size	NPS DN	½	¾	1	1½	2	2½	3	4
		15	20	25	40	50	65	80	100
Ball bore		15	20	25	40	50	65	80	100
L		140	152	165	191	216	240	250	280
H		104	106	129	118	124	157	166	204
D		130	130	160	230	230	400	400	460

# Class 150/300 Stainless Steel/Carbon Steel Ball Valves

## Reduced bore, Uni-body, End entry design

### Features

- Antistatic device
- Blowout-proof stem
- Fire test certification\* (API 607)
- Double "D" stem head
- High performance **HYPATITE® PTFE** ball seats
- Actuator mounting pad to ISO 5211

- Conform to NACE MR0175 for hardness of body, body insert, stem and ball.

Page 96 for Pressure-Temperature Ratings.

Page 45 for Construction and Materials.

Page 94 for Dimension of Actuator Mounting Pad.

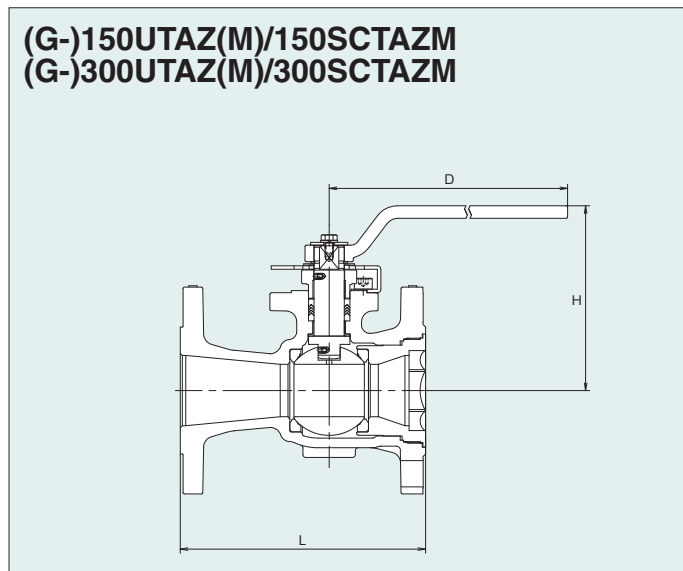

### Dimensions of 150UTAZ(M)/150SCTAZM

Unit: mm

Nominal Size	NPS	1/2	3/4	1	1 1/2	2	3	4	6	8	10
	DN	15	20	25	40	50	80	100	150	200	250
Ball bore		10	12.5	17.5	30	38	58	76	100	151	187
L		108	117	127	165	178	203	229	267	292	330
H		92	95	110	127	134	173	189	224	315	392
D		130	130	130	160	230	400	400	460	1000	1500

### Dimensions of 300UTAZ(M)/300SCTAZM

Unit: mm

Nominal Size	NPS	1/2	3/4	1	1 1/2	2	3	4	6	8	10
	DN	15	20	25	40	50	80	100	150	200	250
Ball bore		10	12.5	17.5	30	38	58	76	100	151	187
L		140	152	165	190	216	283	305	403	419	457
H		92	95	110	127	134	173	189	251	315	392
D		130	130	130	160	230	400	400	750	1000	1500

### Valve operator

NPS 1/2 to 10: Lever operation  
NPS 6 to 10: Optional gear operation

### Options

- ★ Flexible graphite packing and gasket (See Pages 11 and 45)
- Ball and stem to CF8M (316) (150SCTAZM)

### Valve operator

NPS 1/2 to 10: Lever operation  
NPS 6 to 10: Optional gear operation

### Options

- ★ Flexible graphite packing and gasket (See Pages 11 and 45)
- Ball and stem to CF8M (316) (300SCTAZM)

### Gear Operation

Unit: mm

Nominal Pressure	Class 150	Class 300	Gear Operator			
			H	D	C	A
Nominal size (NPS)	6	6	267	300	283	71
	8	8	336	300	283	71
	10	10	400	400	337	86

Refer to "Product Range" on Page 1.

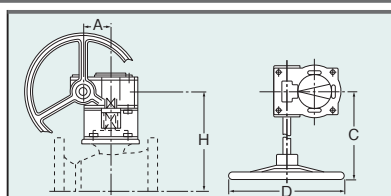

Worm gear operators may be mounted on KITZ ball valves at your option for the smoothest valve operation. Electric or pneumatic actuators are also optionally available. Contact KITZ distributors for appropriate choice and sizing of valve actuators.

\* The position of hand wheel may differ depending on sizes and classes. Please consult KITZ for more details on the specifications.



## Class 150/300 Stainless Steel Floating Ball Valve (Reduced Bore)

### (G-)150/300UTAZL(M)

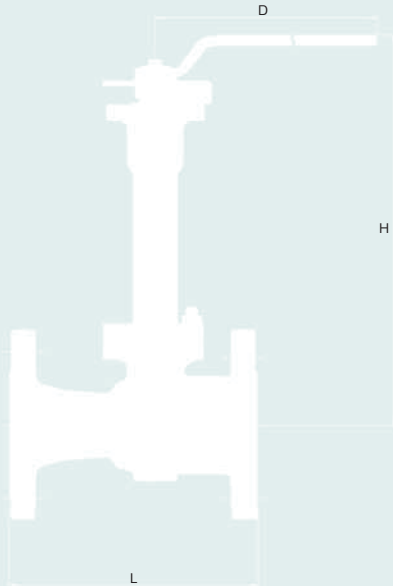

Page 104 for Pressure-Temperature Ratings.

#### Design Specifications

Items	
Wall thickness	ASME B16.34
Face to face dimensions	ASME B16.10
Flange	ASME B16.5

#### Materials

Name of Parts	Materials
Body	CF8 (CF8M)
Bonnet	316SS
Insert	316SS
Stem	316SS/XM-19H
Seat spring	INCONEL <sup>®</sup> X-750 (NPS 3 & larger)
Ball	316SS
Gland	CF8M
Gland packing	Flexible graphite
Ball seat (Body side)	PCTFE (NPS 2 and smaller) HYPATITE <sup>®</sup> PTFE (NPS 3 and larger)
Ball seat (insert side)	HYPATITE <sup>®</sup> PTFE
Gasket	Flexible graphite spiral wound PTFE+Flexible graphite
Bonnet bolt	A320 Gr. B8M
Bonnet nut	A194 Gr. 8M

#### Dimensions of Class 150 RF-flanged 150UTAZL(M)

Unit: mm

Nominal Size	NPS	1/2	3/4	1	1 1/2	2	3	4	6	8	10
	DN	15	20	25	40	50	80	100	150	200	250
L		108	117	127	165	178	203	229	267	292	330
H		307	309	331.7	405	421	549.6	565.6	※	※	※
D		130	130	130	160	230	700	700	※	※	※

#### Dimensions of Class 300 RF-flanged 300UTAZL(M)

Unit: mm

Nominal Size	NPS	1/2	3/4	1	1 1/2	2	3	4	6	8	10
	DN	15	20	25	40	50	80	100	150	200	250
L		140	152	165	190	216	283	305	403	419	457
H		307	309	331.7	405	421	549.6	※	※	※	※
D		130	130	130	160	400	700	※	※	※	※

※Gear operation only. Please contact KITZ Corporation for details.

# Class 150 10K Stainless Steel Floating Ball Valve (Full Bore)

## (G-)150/10UTDZL(M)

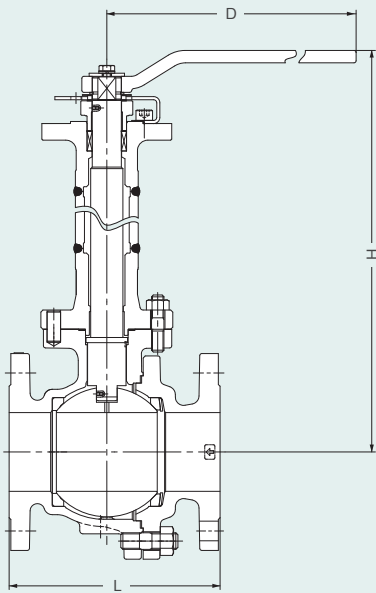

Page 105 for Pressure-Temperature Ratings.

### Design Specifications

Items	
Wall thickness	ASME B16.34
Face to face dimensions	ASME B16.10
Flange	JIS B 2220 (10K/20K)
	ASME B16.5 (150/300)

### Materials

Name of Parts	Materials
Body	CF8 (CF8M <sup>*1</sup> )
Body cap	CF8 (CF8M <sup>*1</sup> )
Bonnet	Type304 (316 <sup>*1</sup> )
Stem	Type304 (316 <sup>*1 *2</sup> )
Seat spring	Type304 <sup>*3</sup> (NPS 2 & larger)
Ball	304SS (316 <sup>*1</sup> )
Ball seat (Body cap side)	HYPATITE <sup>®</sup> PTFE
Ball seat (Body side)	PCTFE (NPS 1 1/2 & smaller)
Gasket	Flexible graphite spiral wound
	Flexible graphite sheet
Cap & bonnet bolt	A193 Gr.B8
Cap & bonnet nut	A194 Gr.8
Gland packing	Flexible graphite

<sup>\*1</sup>CF8M/316 are available for (M).

<sup>\*2</sup>A638 Gr.660 are available for NPS 10 and 20K/  
Class300 NPS 2 and larger.

<sup>\*3</sup>INCONEL<sup>®</sup> X-750 are available for (M).

### Dimensions of Class 150 RF-flanged 150UTDZL(M)

Unit: mm

Nominal Size	NPS	1/2	3/4	1	1 1/4	1 1/2	2	2 1/2	3	4	5	6	8	10
	DN	15	20	25	32	40	50	65	80	100	125	150	200	250
L		108	117	127	140	165	178	190	203	229	356	394	457	533
H		330	333	354	358	421	430	526	536	619	635	758	849	937
D		130	130	160	160	230	230	400	400	Gear operation	Gear operation	Gear operation	Gear operation	Gear operation

### Dimensions of Class 10K RF-flanged 10UTDZL(M)

Unit: mm

Nominal Size	NPS	1/2	3/4	1	1 1/4	1 1/2	2	2 1/2	3	4	5	6	8	10
	DN	15	20	25	32	40	50	65	80	100	125	150	200	250
L		108	117	127	140	165	178	190	203	229	356	394	457	533
H		330	333	354	358	421	430	526	536	619	635	758	841	937
D		130	130	160	160	230	230	400	400	Gear operation	Gear operation	Gear operation	Gear operation	Gear operation

### Gear Operation

Unit: mm

Nominal Pressure	Class 150	10K	Gear Operator			
			H	D	C	A
Nominal size (NPS)	4	4	619	310	165	65.5
	5	5	635	310	165	65.5
	6	6	758	360	210	88.5
	8		849	500	377	134
	10	10	937	500	377	134

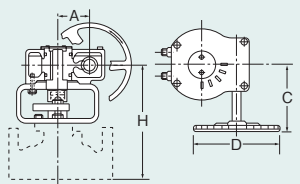

Refer to "Product Range" on Page 1.

# Class 300 20K Stainless Steel Floating Ball Valve (Full Bore)

## (G-)300/20UTDZL(M)

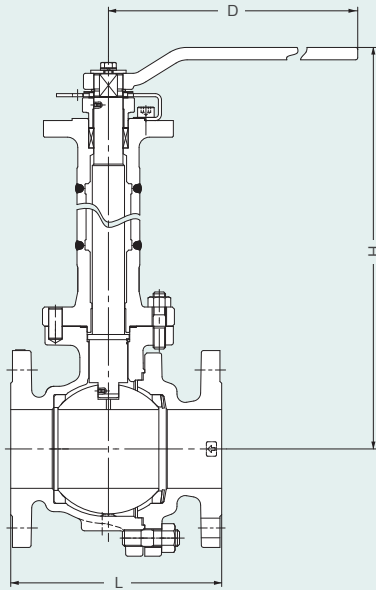

Page 105 for Pressure-Temperature Ratings.

### Design Specifications

Items	
Wall thickness	ASME B16.34
Face to face dimensions	ASME B16.10
Flange	JIS B 2220 (10K/20K)
	ASME B16.5 (150/300)

### Standard Materials

Name of Parts	Materials
Body	CF8 (CF8M <sup>*1</sup> )
Body cap	CF8 (CF8M <sup>*1</sup> )
Bonnet	Type304 (316 <sup>*1</sup> )
Stem	Type304 (316 <sup>*1</sup> * <sup>2</sup> )
Seat spring	Type304 <sup>*3</sup> (NPS 2 & larger)
Ball	304SS (316 <sup>*1</sup> )
Ball seat A (Body cap side)	HYPATITE <sup>®</sup> PTFE
Ball seat B (Body side)	PCTFE (NPS 1½ & smaller)
Gasket	Flexible graphite spiral wound Flexible graphite sheet
Cap& bonnet bolt	B8/8
Cap& bonnet nut	B8/8
Gland packing	Flexible graphite

<sup>\*1</sup>CF8M/316 are available for (M).

<sup>\*2</sup>A638 Gr.660 are available for NPS 10 and 20K/Class300 NPS 2 and larger.

<sup>\*3</sup>INCONEL<sup>®</sup> X-750 are available for (M).

### Dimensions of Class 300 RF-flanged 300UTDZL(M)

Unit: mm

Nominal Size	NPS	1/2	3/4	1	1¼	1½	2	2½	3	4	5	6	8
	DN	15	20	25	32	40	50	65	80	100	125	150	200
L		140	152	165	—	190	216	241	283	305	—	403	502
H		330	333	354	—	421	435	557	557	619	—	755	849
D		130	130	160	—	230	300	600	Gear operation	Gear operation	—	Gear operation	Gear operation

### Dimensions of Class 20K RF-flanged 20UTDZL(M)

Unit: mm

Nominal Size	NPS	1/2	3/4	1	1¼	1½	2	2½	3	4	5	6	8
	DN	15	20	25	32	40	50	65	80	100	125	150	200
L		140	152	165	178	190	216	241	283	305	381	403	502
H		330	333	354	358	421	435	557	557	619	663	755	849
D		130	130	160	160	230	300	600	Gear operation	Gear operation	Gear operation	Gear operation	Gear operation

### Gear Operation

Unit: mm

Nominal Pressure	Class 300	20K	Gear Operator			
			H	D	C	A
Nominal size (NPS)	3	3	557	310	165	65.5
	4	4	619	310	165	65.5
	6	6	755	500	363	93.5
	8	8	849	500	377	134

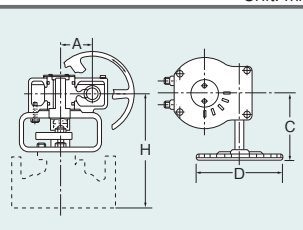

Refer to "Product Range" on Page 1.

# Class 150 Low Temperature Service Ball Valves

## Full bore, Split body, Side entry design

### Features

- Extended bonnet for assured stem seal and freezing prevention.
- Bolted bonnet with body seal gasket.
- Protection of stem alignment by means of two bearings built on top and bottom of stem extension.

Page 100 for Pressure-Temperature Ratings.

### Lowest working temperature: -104°C

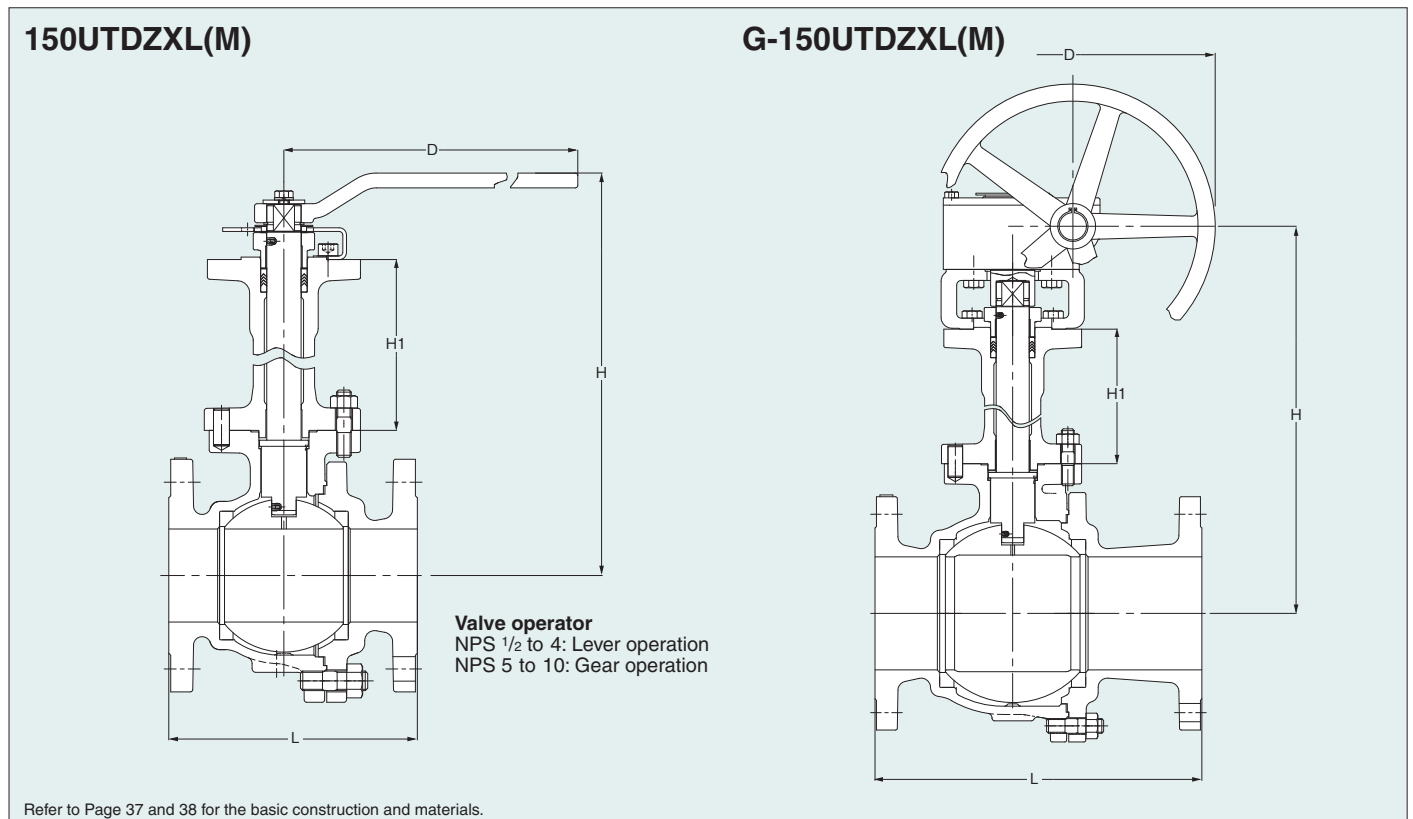

Refer to Page 37 and 38 for the basic construction and materials.

### Dimensions of 150UTDZXL(M)

Unit: mm

Nominal Size	NPS	1/2	3/4	1	1 1/4	1 1/2	2	2 1/2	3	4
	DN	15	20	25	32	40	50	65	80	100
Ball bore		14	19	24	32	38	50	64	76	100
L		108	117	127	140	165	178	190	203	229
H		228	231	268	272	300	309	373	383	458
H1		120	120	143	143	165	165	194	194	207
D		130	130	160	160	230	230	400	400	750

### Dimensions of G-150UTDZXL(M)

Unit: mm

Nominal Size	NPS	5	6	8	10
	DN	125	150	200	250
Ball bore		123	151	202	253
L		356	394	457	533
H		482	572	685	724
H1		207	236	268	268
D		310	360	500	500

Refer to "Product Range" on Page 1.

### Materials

Parts	Materials
Body	CF8 (CF8M*)
Body cap	CF8 (CF8M*)
Bonnet	CF8 (CF8M*)
Stem	Type304 (316*)
Ball	Type304(316*)/CF8(CF8M*)
Gland	CF8
Gland packing	PTFE
Ball seat	HYPATITE® PTFE
Gasket	Flexible graphite spiral wound Ceramic filled PTFE
Cap& bonnet bolt	A193 Gr.B8
Cap&bonnet nut	A194 Gr.8

\* CF8M/316 are available for (M).

# Class 300 Low Temperature Service Ball Valves

## Full bore, Split body, Side entry design

### Features

- Extended bonnet for assured stem seal and freezing prevention.
- Bolted bonnet with body seal gasket.
- Protection of stem alignment by means of two bearings built on top and bottom of stem extension.

Page 100 for Pressure-Temperature Ratings.

**Lowest working temperature: -104°C**

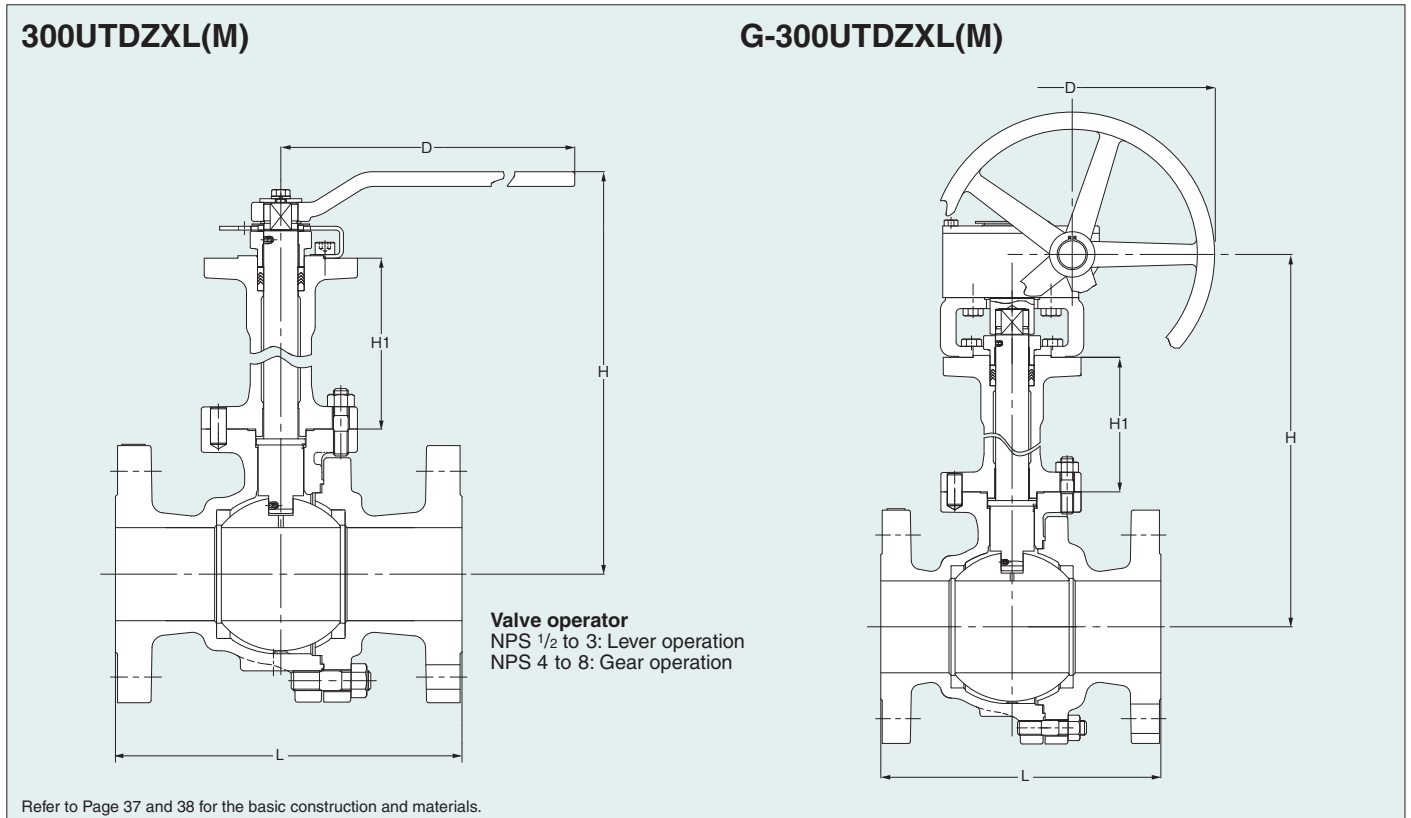

### Dimensions of 300UTDZXL(M)

Nominal Size	NPS	1/2	3/4	1	1 1/2	2	2 1/2	3
	DN	15	20	25	40	50	65	80
Bore size		14	19	24	38	50	64	76
L		140	152	165	190	216	241	283
H		228	231	268	300	309	373	383
H1		120	120	143	165	165	194	194
D		130	130	160	230	230	400	400

### Dimensions of G-300UTDZXL(M)

Nominal Size	NPS	4	6	8
	DN	100	150	200
Bore size		100	151	202
L		305	403	502
H		466	569	685
H1		207	236	268
D		310	500	500

※Nominal size NPS 1 1/4 and 5 are available.  
Refer to "Product Range" on Page 1.

### Materials

Parts	Materials
Body	CF8 (CF8M*)
Body cap	CF8 (CF8M*)
Bonnet	CF8 (CF8M*)
Stem	Type304 (316*)
Ball	Type304(316*)/CF8(CF8M*)
Gland	CF8
Gland packing	PTFE
Ball seat	HYPATITE® PTFE
Gasket	Flexible graphite spiral wound Ceramic filled PTFE
Cap& bonnet bolt	A193 Gr.B8
Cap&bonnet nut	A194 Gr.8

\* CF8M/316 are available for (M).

## 10K Ball Valve (Full Bore)

### (G)-10STBF (G)-10STLBF (Gas service)

FF-flanged

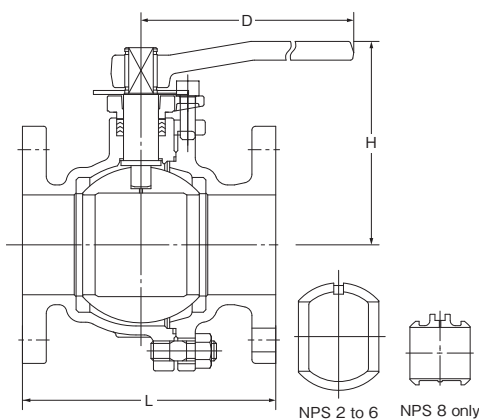

Face to face dimensions : ASME B16.10  
End flanges : JIS B 2239 10K (FF)

#### Dimensions of 10STBF, 10STLBF

Unit: mm

Nominal Size	NPS	1/2	3/4	1	1 1/4	1 1/2	2	2 1/2	3	4	5	6	8
	DN	15	20	25	32	40	50	65	80	100	125	150	200
L		108	117	127	140	165	178	190	203	229	356	394	457
H		106	109	130	135	115	120	153	162	199	219	293	352
D		130	130	160	160	230	230	400	400	460	460	1000	1500

※RF-flanged ends are optionally available.

#### Gear Operation

Unit: mm

Nominal Pressure	10K	Gear Operator			
		H	D	C	A
Nominal size (NPS)	2 1/2	260	175	140	65.5
	3	269	185	150	65.5
	4	292	210	175	65.5
	5	312	250	210	65.5
	6	337	280	240	65.5
	8	414	330	290	88.5

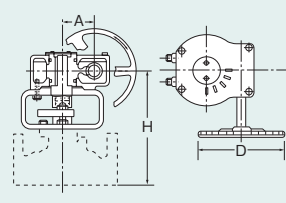

#### Maximum Service Pressure

Code	Valve Size	Temperature	Pressure
10STBF	All size	-10~120°C W.O.G.	1.4 MPa
10STLBF	All size	-10~80°C gas	1.2 MPa

●Use for lubricating or hydraulic oil is acceptable.

#### Materials

Parts	JIS Material
Body	FCD-S
Body cap	FCD-S
Stem	SUS 403
Ball	SUS 304 / SCS 13A / SUS 304TP
Gland	FCD-S
Gland packing	PTFE
Gasket	PTFE
Packing washer	SUS 304 (1/2 to 1 1/4)
Ball seat	HYPATITE® PTFE*1
Cap bolt/nut	SS 400*2
Gland bolt	Alloy steel
O ring*3	NBR
Stopper	SUS 430
Name plate*3	SUS 304

\*1 PTFE or C/F PTFE is optionally available.

\*2 Different bolt/nut material is required for service exceeding temperature range of 0 to 225°C .  
Contact KITZ Corporation for technical advice.

\*3 for 10STLB only

Contact KITZ Corporation for use of valve actuators.

## 20K Ball Valve for Gas Service (Full Bore)

### (G)- 20STLB

RF-flanged

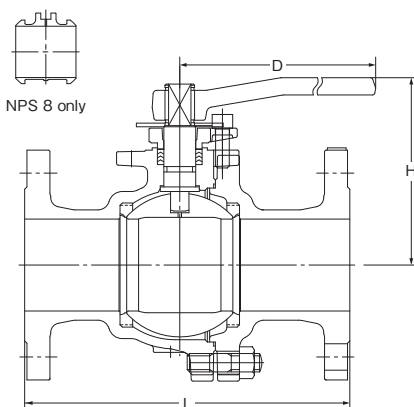

Face to face dimensions : ASME B16.10  
End flanges : JIS B 2239 20K

-10~80°C Gas ..... 2.4 MPa

#### Materials

Parts	JIS Material
Body	FCD-S
Body cap	FCD-S
Stem	SUS 403
Ball	SUS 304 / SCS 13A
Gland	FCD-S
Gland packing	PTFE
Gasket	PTFE
Packing washer	SUS 304 (NPS 1 1/4 & smaller)
Ball seat	HYPHTITE® PTFE
O-ring	NBR
Cap bolt/nut	Carbon steel
Stopper	SUS 430
Snap ring	SK5

#### Dimensions of 20STLB

Unit: mm

Nominal Size	NPS	1/2	3/4	1	1 1/4	1 1/2	2	2 1/2	3	4	6	8
	DN	15	20	25	32	40	50	65	80	100	150	200
L		140	152	165	178	190	216	241	283	305	403	502
H		106	109	130	135	115	120	153	162	241	293	352
D		130	130	160	160	230	230	400	400	750	1000	1500

Refer to "Product Range" on Page 3.

※Please contact KITZ or KITZ distributors for details about gear operated products.

# 10K Ball Valve 3-way 4-seat

## 10STB4LAF

(L-port. Full Bore NPS 1½ to 4)

## 10STB4TAF

(T-port. Full Bore NPS 1½ to 4)

## 10STR4LAF

(L-port. Reduced Bore NPS 5 and larger)

## 10STR4TAF

(T-port. Reduced Bore NPS 5 and larger)

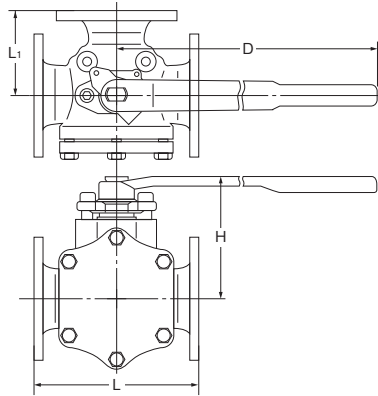

End to end dimensions : KITZ Std.  
End flanges : JIS B 2239 10K (FF)

-10~90°C W.O.G. .... 1.4 MPa

### Materials

Code	JIS Material
Body	FCD-S
Body cap	FCD-S
Ball	SCS 13A or SUS304
Stem	SUS 304
Ball seat	HYPATITE® PTFE
Gland packing	PTFE

Gear operators may be optionally used for NPS 6 and 8.

● Page 107 for Allowable Port Orientation.

### Dimensions of 10STB4LAF, 10STB4TAF, 10STR4LAF, 10STR4TAF

Unit: mm

Nominal Size	NPS	1½	2	2½	3	4	5	6	8
	DN	40	50	65	80	100	125	150	200
L	(STB)	180	200	240	260	330	—	—	—
	(STR)	—	—	—	—	—	340	400	450
L <sub>1</sub>	(STB)	90	100	120	130	165	—	—	—
	(STR)	—	—	—	—	—	170	200	225
H	(STB)	143	152	183	190	259	—	—	—
	(STR)	—	—	—	—	—	267	289	334
D	(STB)	400	400	460	460	1000	—	—	—
	(STR)	—	—	—	—	—	1000	1000	1500

※RF-flanged ends are optionally available.



## CLASS 125 Iron Ball Valves (Full Bore)

### (G-)125FCTB

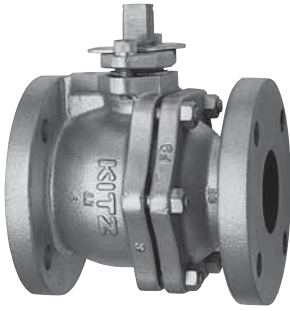

Blowout-proof stem

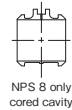
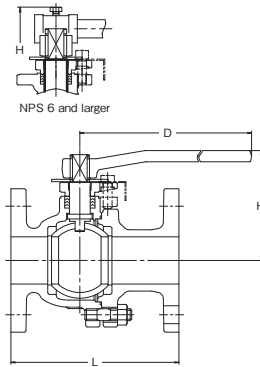

NPS 8 only  
cored cavity

#### Materials

Page 99 for Pressure-Temperature Ratings.

Parts	Material	ASTM Spec.
Body	Cast iron	A126 CL. B
Body cap	Cast iron	A126 CL. B
Stem	Stainless steel	A276 Type403
Ball	Stainless steel	A276 Type 304 or A312 Gr.TP304 or A351 Gr.CF8
Grand packing		PTFE
Gasket		PTFE
Ball seat		PTFE
Cap bolt		Carbon steel

#### Design Specifications

Items	
Shell wall thickness and general valve design	KITZ standard
Face to face dimensions End to end dimensions	ASME B16.10 Class 150
End flange dimensions Gasket contact facing	ASME B16.1 Class 125

#### Dimensions of 125FCTB

Unit: mm

Nominal Size	NPS	2	2½	3	4	6	8
	DN	50	65	80	100	150	200
L		178	190	203	229	394	457
H		120	155	165	200	295	355
D		230	400	400	460	1000	1500

※Please contact KITZ or KITZ distributors for details about gear operated products.

## CLASS 125 Iron Ball Valves (Reduced Bore)

### 125FCTR

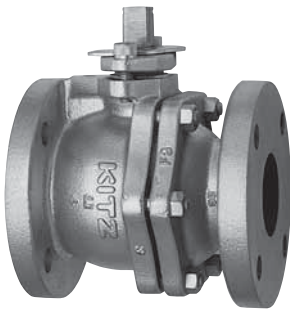

Blowout-proof stem

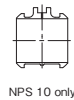
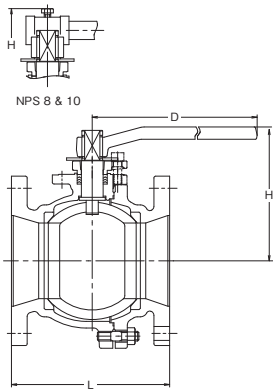

NPS 10 only

#### Materials

Page 99 for Pressure-Temperature Ratings.

Parts	Material	ASTM Spec.
Body	Cast iron	A126 CL. B
Body cap	Cast iron	A126 CL. B
Stem	Stainless steel	A276 Type 403
Ball	Stainless steel	A312 Gr.TP304 or A351 Gr.CF8
Grand packing		PTFE
Gasket		PTFE
Ball seat		PTFE
Cap bolt		Carbon steel

#### Design Specifications

Items	
Shell wall thickness and general valve design	KITZ standard
Face to face dimensions End to end dimensions	ASME B16.10 Class 150
End flange dimensions Gasket contact facing	ASME B16.1 Class 125

#### Dimensions of 125FCTR

Unit: mm

Nominal Size	NPS	6	8	10
	DN	150	200	250
L		267	292	330
H		220	295	355
D		460	1000	1500

# 10K Iron Ball Valves (Full Bore)

## (G)-10FCTB

Page 99 for Pressure-Temperature Ratings.

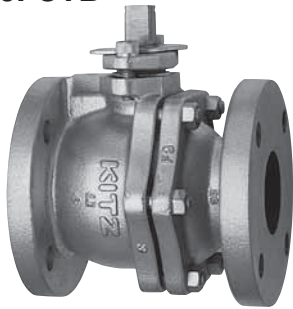

Blowout-proof stem

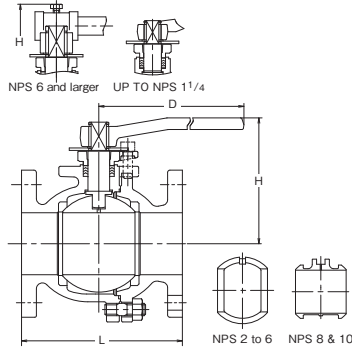

### Materials

Parts	Material	JIS Spec.
Body	Cast iron	FC200
Body cap	Cast iron	FC200
Stem	Stainless steel	SUS403
Ball	Stainless steel	SCS13A or SUS304 or SUS304TP
Grand packing		PTFE
Gasket		PTFE
Ball seat		PTFE
Cap bolt	Carbon steel	SS400

### Design Specifications

Items	
Shell wall thickness and general valve design	KITZ standard
Face to face dimensions	KITZ standard
End flange dimensions Gasket contact facing	JIS B2239 10K (FF)

### Gear Operation

Unit: mm

Nominal Pressure	10K	Gear Operator			
		H	D	C	A
Nominal size (NPS)	5	312	310	165	65.5
	6	337	310	165	65.5
	8	414	360	210	88.5
	10	477	500	363	93.5

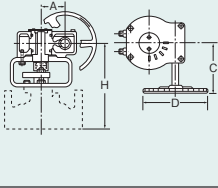

### Dimensions of 10FCTB

Unit: mm

Nominal Size	NPS DN	1/2	3/4	1	1 1/4	1 1/2	2	2 1/2	3	4	5	6	8	10
				15	20	25	32	40	50	65	80	100	125	150
L		110	120	130	140	165	180	190	200	230	300	340	450	533
H		102	105	124	128	114	121	154	163	199	219	292	352	477
D		130	130	160	160	230	230	400	400	460	460	1000	1500	—

Refer to "Product Range" on Page 3.

# JIS 10K Iron Ball Valves (Reduced Bore)

## (G)-10FCTR

Page 99 for Pressure-Temperature Ratings.

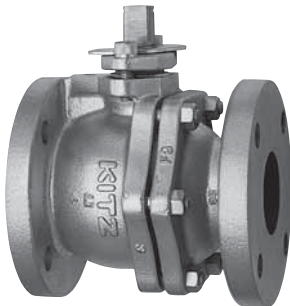

Blowout-proof stem

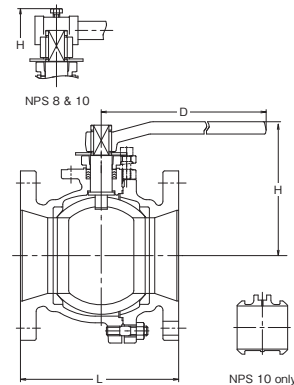

### Materials

Parts	Material	JIS Spec.
Body	Cast iron	FC200
Body cap	Cast iron	FC200
Stem	Stainless steel	SUS403
Ball	Stainless steel	SCS13A or SUS304 or SUS304TP
Grand packing		PTFE
Gasket		PTFE
Ball seat		PTFE
Cap bolt	Carbon steel	SS400

### Design Specifications

Items	
Shell wall thickness and general valve design	KITZ standard
Face to face dimensions	JIS B2002*
End flange dimensions Gasket contact facing	JIS B2239 10K (FF)

\* For NPS 5=KITZ standard

### Gear Operation

Unit: mm

Nominal Pressure	10K	Gear Operator			
		H	D	C	A
Nominal size (NPS)	5	292	310	165	65.5
	6	312	310	165	65.5
	8	337	310	165	65.5
	10	414	360	210	88.5

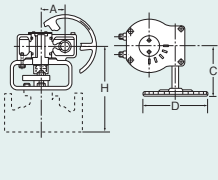

### Dimensions of 10FCTR

Unit: mm

Nominal Size	NPS DN	5	6	8	10
				125	150
L		250	270	290	330
H		200	220	295	355
D		460	460	1000	1500

Refer to "Product Range" on Page 3.

## 10K Iron Ball Valves 3-way (Full or Reduced Bore)

Page 99 for Pressure-Temperature Ratings.

### 10FCTB2L

• Full Bore: NPS 1 1/2 to 4

### 10FCTR2L

• Reduced Bore: NPS 5 to 8

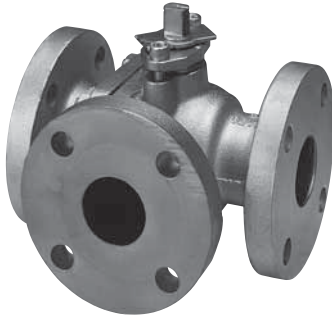

Blowout-proof stem

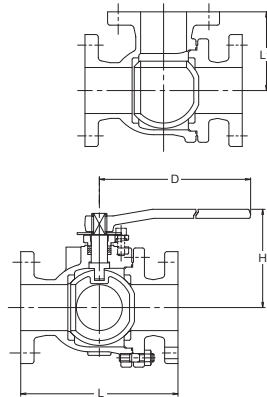

### Materials

Parts	Material	JIS Spec.
Body	Cast iron	FC200
Body cap	Cast iron	FC200
Stem	Stainless steel	SUS403
Ball	Stainless steel	SCS13
Grand packing	PTFE	
Gasket	PTFE	
Ball seat	PTFE	
Cap bolt/nut	Carbon steel	SS400

• Page 107 for Allowable Port Orientation.

### Design Specifications

Items	
Shell wall thickness	JIS B2031
Face to face dimensions	KITZ standard
End flange dimensions Gasket contact facing	JIS B2239 10K (FF)

### Dimensions of 10FCTB2L, 10FCTR2L

Unit: mm

Nominal Size	NPS	1 1/2	2	2 1/2	3	4	5	6	8
	DN	40	50	65	80	100	125	150	200
L		210	220	250	260	330	370	430	540
L <sub>1</sub>		105	110	125	130	165	185	215	270
H		115	120	155	165	200	205	225	295
D		230	230	400	400	460	460	460	1000

※Please contact KITZ or KITZ distributors for details about gear operated products.

## Bronze Ball Valves

W.O.G. non-shock 1.4 MPa

W.O.G. 150°C 0.7 MPa

Bolted body cap, Full bore  
Flanged ends to JIS B2240 10K

### TB

• Flanged ends to JIS 10K

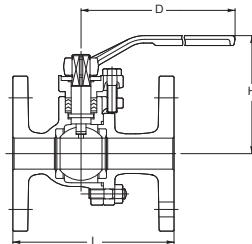

### Materials

Parts	Material
Body	Bronze
Body cap	Bronze
Stem	Dezincification resistant brass
Ball	Brass <sup>*1</sup> /SCS13A <sup>*2</sup> /SUS304 <sup>*3</sup>
Ball seat	PTFE
Grand packing	PTFE

<sup>\*1</sup>Chrome or Nickel-chrome plated

<sup>\*2</sup>NPS 2-3

<sup>\*3</sup>NPS 4

### Dimensions of TB

Unit: mm

Nominal Size	NPS	1/2	3/4	1	1 1/4	1 1/2	2	2 1/2	3	4
	DN	15	20	25	32	40	50	65	80	100
L		110	120	130	140	165	180	190	200	230
H		85	88	95	100	115	122	153	162	190
D		130	130	160	160	230	230	400	400	460

## Construction and Materials

### Parts List :1H

No.	Parts	Standard	Fire-safe
		150/300SCTDZ	150/300SCTDZ-FS
1	Body* <sup>1</sup>	A216 Gr.WCB	
2	Body cap* <sup>1</sup>	A216 Gr.WCB	
3	Stem	A276 Type 304	
4	Ball* <sup>2</sup>	A276 Type 304 or A351 Gr.CF8 or A182 Gr.F304	
7	Gland	A351 Gr.CF8	
8	Gland packing	PTFE	Flexible graphite
9	Handle* <sup>3</sup>	Ductile iron	
9A	Handle bar* <sup>3</sup>	Carbon steel	
9B	Handle head* <sup>3</sup>	Ductile iron	
16	Name plate	Stainless steel	
19	Gasket	PTFE	Flexible graphite
20	Packing washer* <sup>4</sup>	A276 Type 316L	
30	Ball seat	HYPATITE® PTFE	
33	Cap nut	A194 Gr.2H	
35	Cap bolt	A193 Gr.B7	
36	Gland bolt	Stainless steel	
40	Key-lock plate	Stainless steel	
43	Handle-lock plate	Stainless steel	
48	Snap ring	Stainless steel	
49	Stopper	Stainless steel	
51	Stopper plate	Stainless steel	
57	Gland bush	G/F PTFE	
58	Gland washer	A276 Type 304	
67	Stem bearing	G/F PTFE	
123A	Handle-lock plate bolt	Stainless steel	
123B	Handle bolt	Stainless steel	
124	Spring & pin	A313 & A276 Type 316	
126	Stopper plate bolt	Stainless steel	
145	Coned disc spring	Stainless steel	

No.	Parts	ASTM Material Designation			JIS Material Designation		
		Stainless steel valve		Carbon steel valve	Stainless steel valve		Carbon steel valve
		150/300UTDZ1H	150/300UTDZ1HM	150/300SCTDZ1H	10/20UTDZ1H	10/20UTDZ1HM	10/20SCTDZ1H
1	Body	A351 Gr.CF8	A351 Gr.CF8M	A216 Gr.WCB	SCS13A	SCS14A	SCPH2
2	Body cap	A351 Gr.CF8	A351 Gr.CF8M	A216 Gr.WCB	SCS13A	SCS14A	SCPH2
3	Stem	A276 Type 304	A276 Type 316	A276 Type 304	SUS304	SUS316	SUS304
4	Ball	A276 Type 304 or A351 Gr.CF8 or A182 Gr.F304	A276 Type 316 or A351 Gr.CF8M or A182 Gr.F316	A276 Type 304 or A351 Gr.CF8 or A182 Gr.F304	SUS304 or SCS13A or SUS F304	SUS316 or SCS14A or SUS F316	SUS304 or SCS14A or SUS F304
7	Gland	A351 Gr.CF8			SCS13A		
8	Gland packing	Flexible graphite			Flexible graphite		
9	Handle* <sup>1</sup>	Ductile iron			FCD450-10		
9A	Handle bar* <sup>1</sup>	Carbon steel			SGP		
9B	Handle head* <sup>1</sup>	Ductile iron			FCD450-10		
16	Name plate	Stainless steel			Stainless steel		
19	Gasket	Flexible graphite			Flexible graphite		
20	Packing washer	A276 Type 316L			SUS316L		
30	Ball seat	FILLTITE® PTFE			FILLTITE® PTFE		
33	Cap nut	A194 Gr.8		A194 Gr.2H	A194 Gr.8		A194 Gr.2H
35	Cap bolt	A193 Gr.B8		A193 Gr.B7	A193 Gr.B8		A193 Gr.B7
36	Gland bolt	Stainless steel			Stainless steel		
40	Key-lock plate	Stainless steel			Stainless steel		
43	Handle-lock plate	Stainless steel			Stainless steel		
47	Thrust washer	Carbon (size 1 & over)			Carbon		
48	Snap ring	Stainless steel			Stainless steel		
49	Stopper	Stainless steel			Stainless steel		
51	Stopper plate	A276 Type 304			Stainless steel		
57	Gland bush	Carbon			Carbon		
58	Gland washer	A276 Type 304			SUS304		
67	Stem bearing	Carbon			Carbon		
123A	Handle-lock plate bolt	Stainless steel			Stainless steel		
123B	Handle bolt	Stainless steel			Stainless steel		
124	Spring & pin	A313 & A276 Type 316			SUS316-WPA & SUS316		
126	Stopper plate bolt	Stainless steel			Stainless steel		
145	Coned disc spring	Stainless steel			SUS304-CSP		

\*1 A352 Gr. LCC low-temperature service materials are optionally available.

\*2 CF8M or Type 316 is optionally available for balls and stems.

\*3 Class 150: Bar type handle used for NPS 6 and 8.  
Class 300: Bar type handle used for NPS 4 and 8.

\*4 Up to NPS 1

All part numbers are corresponding with those shown in valve assembly drawings.

\*1) Refer to the following table \*2) Equivalent to AISI Type 329

\* The substitutional equivalent materials may be used for valve part materials where ASTM A276 and/or A564 is stated on the material descriptions in this catalog.

Operation (Standard)	Class 150/10K	Class 300/20K
Lever type	NPS 1/2 to 3	NPS 1/2 to 3
Bar type	NPS 4	
Gear	NPS 5 to 8	NPS 4 to 8

Refer to illustration on Page 38.

## Construction and Materials

### ■ Class 150/300 10/20K Floating Ball Design Valve

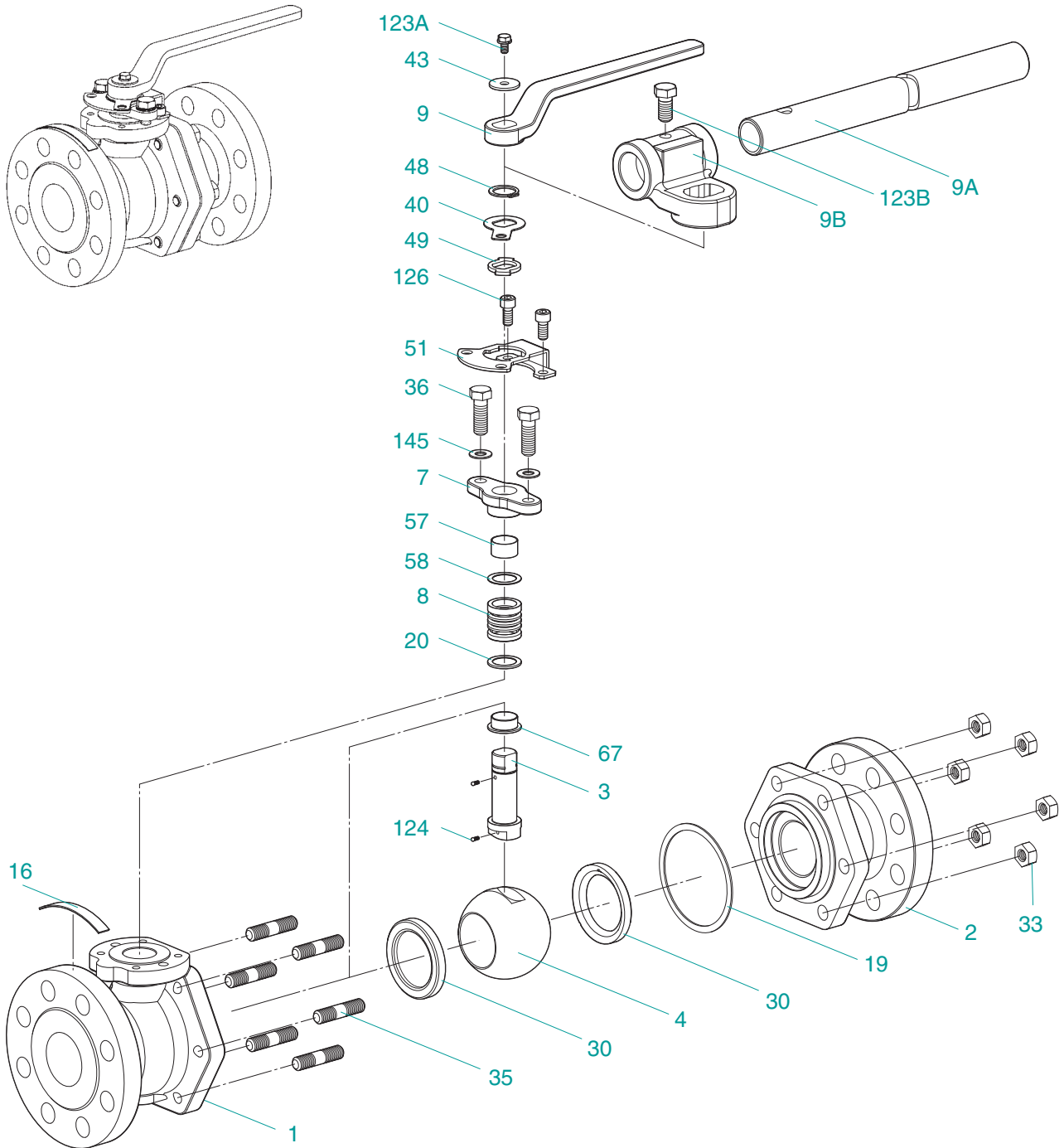

Illustration shows NPS 4 design.

## Construction and Materials

### ■ Class 150/300, 10/20K Metal Seated Floating Ball Valve (Trim 3H)

No.	Parts	ASTM Material Designation (Trim 3H)			JIS Material Designation (Trim 3H)		
		Stainless steel valve		Carbon steel valve	Stainless steel valve		Carbon steel valve
		150/300UTDZ3H	150/300UTDZ3HM	150/300SCTDZ3H	10/20UTDZ3H	10/20UTDZ3HM	10/20SCTDZ3H
1	Body	A351 Gr.CF8	A351 Gr.CF8M	A216 Gr.WCB	SCS13A	SCS14A	SCPH2
2	Body cap	A351 Gr.CF8	A351 Gr.CF8M	A216 Gr.WCB	SCS13A	SCS14A	SCPH2
3	Stem	A276 Type 304	A276 Type 316	A276 Type 304	SUS304	SUS630	SUS304
4	Ball	A276 Type 304 or A182 Gr.F304	A276 Type 316 or A182 Gr.F316	A276 Type 304 or A182 Gr.F304	SUS304 or SUS F304	SUS316 or SUS F316	SUS304 or SUS F304
7	Gland	A351 Gr.CF8			SCS13A		
8	Gland packing	Flexible graphite			Flexible graphite		
9	Handle <sup>*1</sup>	Ductile iron			FCD450-10		
9A	Handle bar <sup>*1</sup>	Carbon steel			SGP		
9B	Handle head <sup>*1</sup>	Ductile iron			FCD450-10		
16	Name plate	Stainless steel			Stainless steel		
19	Gasket	Flexible graphite			Flexible graphite		
20	Packing washer	A276 Type 316L			SUS316L		
30	Ball seat	Carbon + JIS SUS329J1 <sup>*2</sup>			Carbon + SUS329J1		
33	Cap nut	A194 Gr.8		A194 Gr.2H	A194 Gr.8		A194 Gr.2H
35	Cap bolt	A193 Gr.B8		A193 Gr.B7	A193 Gr.B8		A193 Gr.B7
36	Gland bolt	Stainless steel			Stainless steel		
40	Key-lock plate	Stainless steel			Stainless steel		
43	Handle-lock plate	Stainless steel			Stainless steel		
47	Thrust washer	Carbon			Carbon		
48	Snap ring	Stainless steel			Stainless steel		
49	Stopper	Stainless steel			Stainless steel		
51	Stopper plate	Stainless steel			Stainless steel		
57	Gland bush	Carbon			Carbon		
58	Gland washer	A276 Type 304			SUS304		
67	Stem bearing	Carbon			Carbon		
123A	Handle-lock plate bolt	Stainless steel			Stainless steel		
123B	Handle bolt	Stainless steel			Stainless steel		
124	Spring & pin	A313 & A276 Type 316			SUS316-WPA & SUS316		
126	Stopper plate bolt	Stainless steel			Stainless steel		
145	Coned disc spring	Stainless steel			SUS304-CSP		
176	Seat packing	Flexible graphite			Flexible graphite		

\*1 Refer to the following table.

\*2 Equivalent to AISI Type 329

• The substitutional equivalent materials may be used for valve part materials where ASTM A276 and/or A564 is stated on the material descriptions in this catalog.

Operation (Standard)	Class 150/10K	Class 300/20K
Lever type	NPS 1/2 to 11/2	NPS 1/2 to 11/4
Bar type	NPS 2 to 4	NPS 11/2 to 3
Gear	NPS 5 to 8	NPS 4 to 8

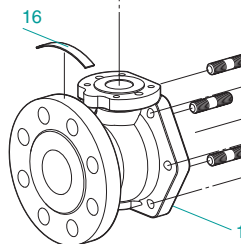
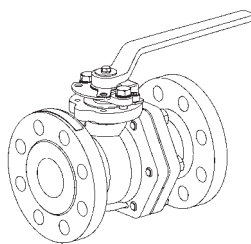
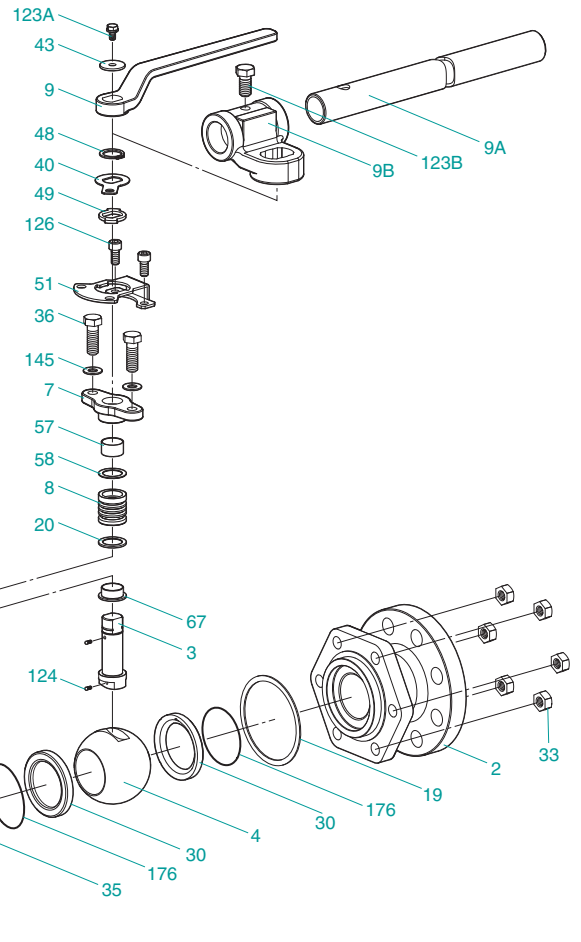

## Construction and Materials

No.	Parts	ASTM Material Designation (Trim 5H)			JIS Material Designation (Trim 5H)		
		Stainless steel valve		Carbon steel valve	Stainless steel valve		Carbon steel valve
		150/300UTDZ5H	150/300UTDZ5HM	150/300SCTDZ5H	10/20UTDZ5H	10/20UTDZ5HM	10/20SCTDZ5H
1	Body	A351 Gr.CF8	A351 Gr.CF8M	A216 Gr.WCB	SCS13A	SCS14A	SCPH2
2	Body cap	A351 Gr.CF8	A351 Gr.CF8M	A216 Gr.WCB	SCS13A	SCS14A	SCPH2
3	Stem	SUS630 or A564 Type 630			SUS630 or A564 Type630		
4	Ball	A276 Type 316 or A182 Gr.F316 with Cr. plating			SUS316 (or SUS F316) with Cr. plating		
7	Gland	A351 Gr.CF8			SCS13A		
8	Gland packing	Flexible graphite			Flexible graphite		
9	Handle <sup>*1</sup>	Ductile iron			FCD450-10		
9A	Handle bar <sup>*1</sup>	Carbon steel			SGP		
9B	Handle head <sup>*1</sup>	Ductile iron			FCD450-10		
16	Name plate	Stainless steel			Stainless steel		
19	Gasket	Flexible graphite			Flexible graphite		
20	Packing washer	A276 Type 316L			SUS316L		
30	Ball seat	A276 Type 316 + Ni-Cr alloy hard facing <sup>*2</sup>			SUS 316 + Ni-Cr alloy hard facing <sup>*2</sup>		
33	Cap nut	A194 Gr.8		A194 Gr.2H	A194 Gr.8		A194 Gr.2H
35	Cap bolt	A193 Gr.B8		A193 Gr.B7	A193 Gr.B8		A193 Gr.B7
36	Gland bolt	Stainless steel			Stainless steel		
40	Key-lock plate	Stainless steel			Stainless steel		
43	Handle-lock plate	Stainless steel			Stainless steel		
47	Thrust washer	Carbon			Carbon		
48	Snap ring	Stainless steel			Stainless steel		
49	Stopper	Stainless steel			Stainless steel		
51	Stopper plate	Stainless steel			Stainless steel		
57	Gland bush	Carbon			Carbon		
58	Gland washer	A276 Type 304		SUS304	SUS304		
67	Stem bearing	Carbon			Carbon		
123A	Handle-lock plate bolt	Stainless steel			Stainless steel		
123B	Handle bolt	Stainless steel			Stainless steel		
126	Stopper plate bolt	Stainless steel			Stainless steel		
145	Coned disc spring	Stainless steel			SUS304-CSP		
176	Seat packing	Flexible graphite			Flexible graphite		

\*1 Refer to the following table.

\*2 Equivalent to METCO Type 16C

• The substitutional equivalent materials may be used for valve part materials where ASTM A276 and/or A564 is stated on the material descriptions in this catalog.

Operation (Standard)	Class 150/10K	Class 300/20K
Lever type	NPS 1/2 to 11/2	NPS 1/2 to 1
Bar type	NPS 2 to 4	NPS 11/2 to 3
Gear	NPS 5 to 8	NPS 4 to 8

### ■ Class 150/300, 10/20K Metal Seated Floating Ball Valve (Trim 5H)

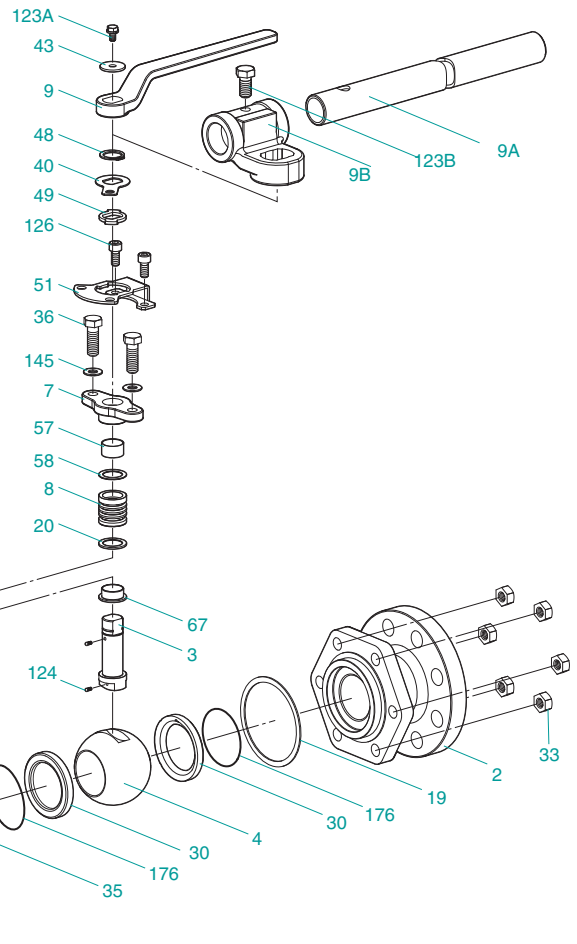



## Construction and Materials

### ■ Class 150/300, 10/20K Metal Seated Floating Ball Design Valve (Trim 6H)

No.	Parts	ASTM Material Designation (Trim 6H)			JIS Material Designation (Trim 6H)		
		Stainless steel valve		Carbon steel valve	Stainless steel valve		Carbon steel valve
		150/300UTDZ6H	150/300UTDZ6HM	150/300SCTDZ6H	10/20UTDZ6H	10/20UTDZ6HM	10/20SCTDZ6H
1	Body	A351 Gr.CF8	A351 Gr.CF8M	A216 Gr.WCB	SCS13A	SCS14A	SCPH2
2	Body cap	A351 Gr.CF8	A351 Gr.CF8M	A216 Gr.WCB	SCS13A	SCS14A	SCPH2
3	Stem	SUS630 or A564 Type 630			SUS630 or A564 Type630		
4	Ball	A276 Type 316 or A182 Gr.F316 with Ni-Cr alloy hard facing			SUS316 or SUS F316 with Ni-Cr alloy hard facing		
7	Gland	A351 Gr.CF8			SCS13A		
8	Gland packing	Flexible graphite			Flexible graphite		
9	Handle <sup>*1</sup>	Ductile iron			FCD450-10		
9A	Handle bar <sup>*1</sup>	Carbon steel			SGP		
9B	Handle head <sup>*1</sup>	Ductile iron			FCD450-10		
16	Name plate	Stainless steel			Stainless steel		
19	Gasket	Flexible graphite			Flexible graphite		
20	Packing washer	A276 Type 316L			SUS316L		
30	Ball seat	316SS + Ni-Cr alloy hard facing			316SS + Ni-Cr alloy hard facing		
33	Cap nut	A194 Gr.8	A194 Gr.2H	A194 Gr.8	A194 Gr.8	A194 Gr.2H	
35	Cap bolt	A193 Gr.B8	A193 Gr.B7	A193 Gr.B7	A193 Gr.B8	A193 Gr.B7	
36	Gland bolt	Stainless steel			Stainless steel		
40	Key-lock plate	Stainless steel			Stainless steel		
43	Handle-lock plate	Stainless steel			Stainless steel		
47	Thrust washer	Carbon			Carbon		
48	Snap ring	Stainless steel			Stainless steel		
49	Stopper	Stainless steel			Stainless steel		
51	Stopper plate	Stainless steel			Stainless steel		
57	Gland bush	Carbon			Carbon		
58	Gland washer	A276 Type 304		SUS304	SUS304		
67	Stem bearing	Carbon			Carbon		
123A	Handle-lock plate bolt	Stainless steel			Stainless steel		
123B	Handle bolt	Stainless steel			Stainless steel		
126	Stopper plate bolt	Stainless steel			Stainless steel		
145	Coned disc spring	Stainless steel			SUS304-CSP		
176	Seat packing	Flexible graphite			Flexible graphite		

\*1 Refer to the following table.

• The substitutional equivalent materials may be used for valve part materials where ASTM A276 and/or A564 is stated on the material descriptions in this catalog.

Operation (Standard)	Class 150/10K	Class 300/20K
Lever type	NPS 1/2 to 11/2	NPS 1/2 to 11/4
Bar type	NPS 2 to 4	NPS 11/2 to 3
Gear	NPS 5 to 8	NPS 4 to 8

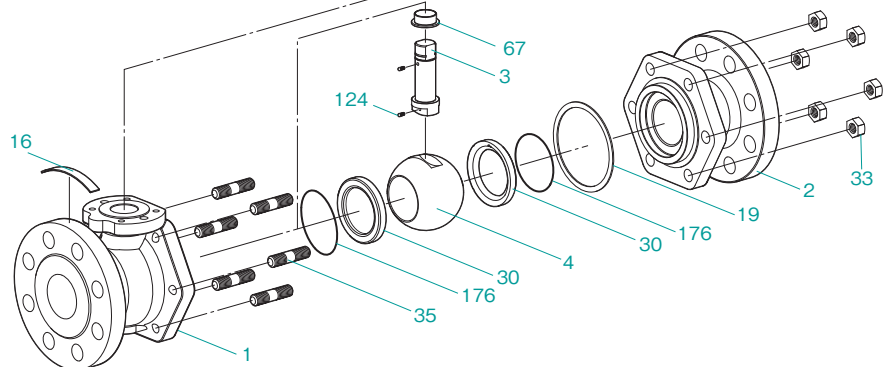
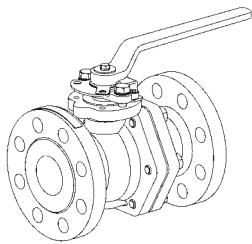
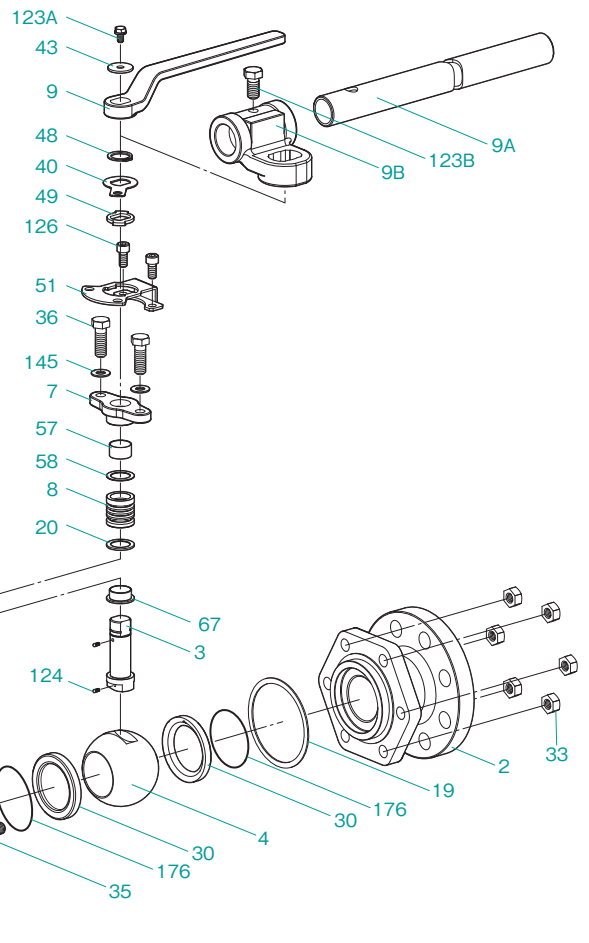

## Construction and Materials

No.	Parts	Standard	Fire-safe
		150SCTAZM 300SCTAZM	150SCTAZM-FS 300SCTAZM-FS
1	Body	A216 Gr. WCB *1	
3	Stem	A276 Type 316*2	
4	Ball	A276 Type 316 / A351 Gr. CF8M	
7	Gland	A351 Gr. CF8M	
8	Gland packing	PTFE	Flexible graphite
9	Handle*3	Ductile iron	
9A	Handle bar	Carbon steel	
9B	Handle head	Ductile iron	
16A	Name plate	Stainless steel	
16B	Lev plate	Stainless steel	
19A	Gasket	PTFE	
19B	Gasket	—	Flexible graphite
20	Packing washer	A276 Type 316L	
29	Insert	A216 Gr. WCB / A105	
30	Ball seat	HYPATITE®PTFE	
36	Gland bolt	Stainless steel	
40	Key-lock plate	Stainless steel	
43	Handle-lock plate	Stainless steel	
48	Snap ring	Stainless steel	
49	Stopper	Stainless steel	
51	Stopper plate	Stainless steel	
57	Gland bush	G/F PTFE	
58	Gland washer	A276 Type 304	
67	Stem bearing	G/F PTFE	
123A	Handle-lock plate bolt	Stainless steel	
123B	Handle bolt	Stainless steel	
124	Spring + pin	A313 & A276 Type 316	
126	Stopper plate bolt	Stainless steel	
145	Coned disc spring	Stainless steel	
216A	Ce plate	Stainless steel	
216B	Atex plate	Stainless steel	

■ Standard material configuration can be applied to sour service.

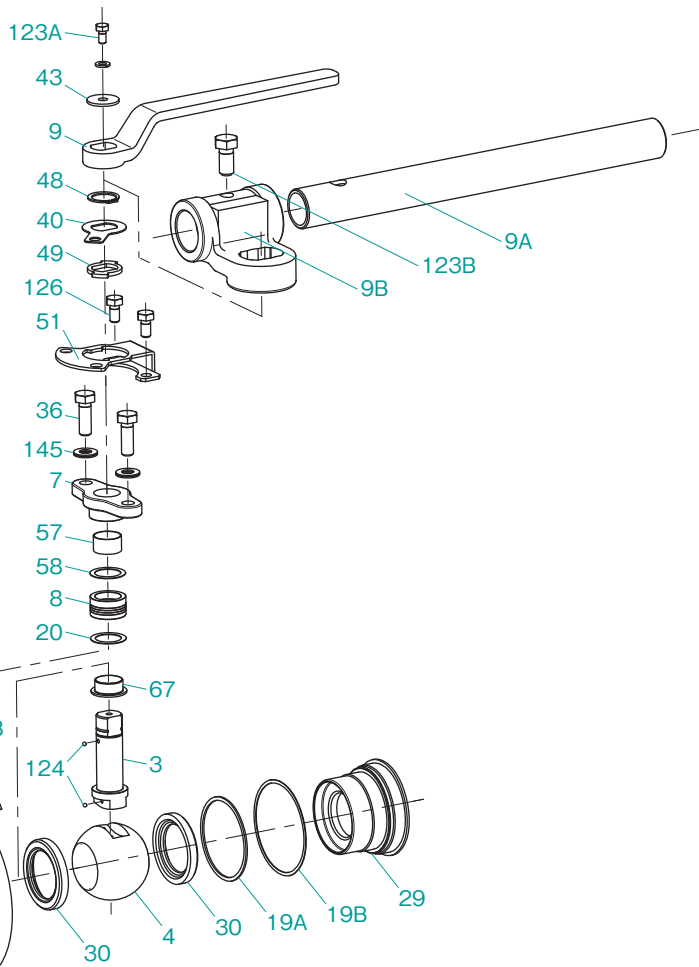

\*1 A352 low-temperature service materials are optionally available.  
 \*2 CF8M or Type 316 is optionally available for balls and stems.  
 \*3 Bar type handles are used for NPS 6 and larger.

All part numbers are corresponding with those shown in valve assembly drawings.

Regarding this specification, there are cases where it is not used. (16B, 19B, 216A, 216B)

Illustration shows NPS 1/2 design.

## Construction and Materials

■ Standard material configuration can be applied to sour service.

No.	Parts	Standard		Fire-safe	
		150UTDZ 300UTDZ	150UTDZM 300UTDZM	150UTDZ-FS 300UTDZ-FS	150UTDZM-FS 300UTDZM-FS
1	Body	A351 Gr.CF8	A351 Gr.CF8M	A351 Gr.CF8	A351 Gr.CF8M
2	Body cap	A351 Gr.CF8	A351 Gr.CF8M	A351 Gr.CF8	A351 Gr.CF8M
3	Stem	A276 Type 304	A276 Type 316	A276 Type 304	A276 Type 316
4	Ball*2	A276 Type 304 or A351 Gr.CF8 or A182 Gr.F304	A276 Type 316 or A351 Gr.CF8M or A182 Gr.F316	A276 Type 304 or A351 Gr. CF8 or A182 Gr.F304	A276 Type 316 or A351 Gr. CF8M or A182 Gr.F316
7	Gland	A351 Gr.CF8			
8	Gland packing	PTFE		Flexible graphite	
9	Handle	Ductile iron			
9A	Handle bar*2	Carbon steel			
9B	Handle head*2	Ductile iron			
16	Name plate	Stainless steel			
19	Gasket	PTFE		Flexible graphite	
20	Packing washer	A276 Type 316L (up to size 1)			
30	Ball seat	HYPATITE® PTFE			
33	Cap nut	A194 Gr.8			
35	Cap bolt	A193 Gr.B8			
36	Gland bolt	Stainless steel			
40	Key-lock plate	Stainless steel			
43	Handle-lock plate	Stainless steel			
48	Snap ring	Stainless steel			
49	Stopper	Stainless steel			
51	Stopper plate	Stainless steel			
57	Gland bush	G/F PTFE			
58	Gland washer	A276 Type 304			
67	Stem bearing	G/F PTFE			
123A	Handle-lock plate bolt	Stainless steel			
123B	Handle bolt	Stainless steel			
124	Spring & pin	A313 & A276 Type 316			
126	Stopper plate bolt	Stainless steel			
145	Coned disc spring	Stainless steel			

\*1 CF8M or Type 316 is optionally available for balls and stems.

\*2 Class 150: Bar type handle used for NPS 6 and 8.

Class 300: Bar type handle used for NPS 4 to 8.

All part numbers are corresponding with those shown in valve assembly drawings.

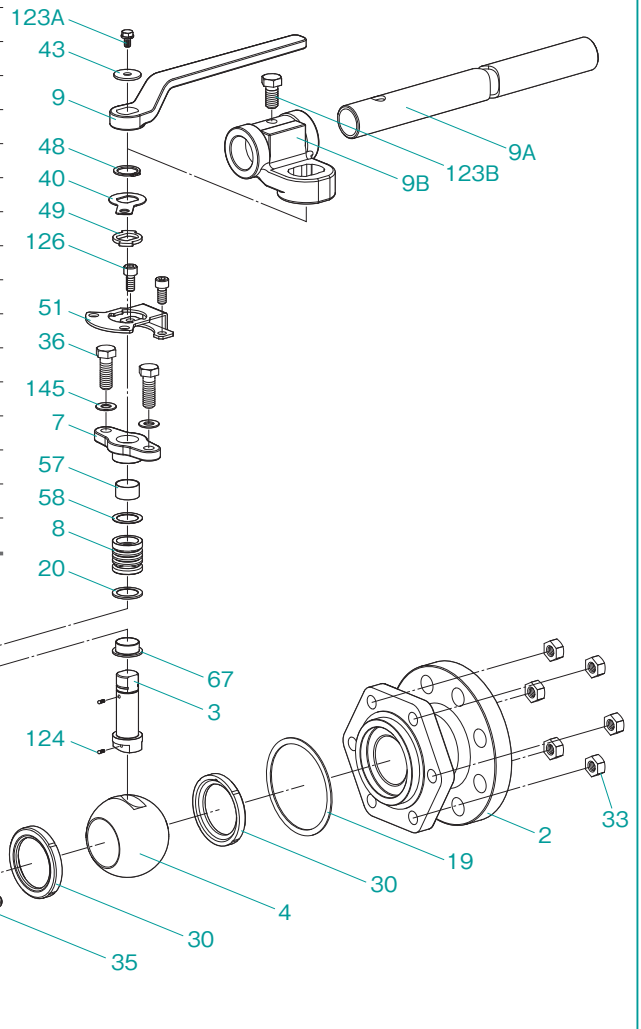

Illustration shows NPS 4 design.

## Construction and Materials

No.	Parts	Standard	
		150UTB	150UTBM
1	Body	A351 Gr. CF8	A351 Gr. CF8M
2	Body cap	A351 Gr. CF8	A351 Gr. CF8M
3	Stem	A276 Type 304	A276 Type 316
4	Ball	A276 Type 304 or A351 Gr. CF8 or A182 Gr.F304	A276 Type 316 or A351 Gr. CF8M or A182 Gr.F316
7	Gland	A351 Gr. CF8	
8	Gland packing	PTFE	
9	Handle* <sup>1</sup>	Ductile iron	
16A	Name plate	Aluminum	
16B	Washer	Carbon steel	
19	Gasket	PTFE	
20	Packing washer* <sup>2</sup>	A276 Type 316L	
30	Ball seat	HYPATITE® PTFE	
33	Cap nut	A194 Gr. 8	
35	Cap bolt	A193 Gr. B8	
36	Gland bolt	Stainless steel	
47	Thrust washer	G/F PTFE (size 4 & over)	
48	Snap ring	Stainless steel	
49	Stopper	Stainless steel	
67	Stem bearing	G/F PTFE	
123	Handle bolt	NPS 6 to 10	Carbon steel
124A	Spring & pin	NPS 2 1/2 to 10	A313 & A276 Type 316
124B	Spring	NPS 1 1/2 to 2	A313 Type 316

\*1 Bar type handles are used for NPS 6 and 8. Worm gear operations are used for NPS10.  
 \*2 Packing washers are used only for NPS 1 and smaller.

All part numbers are corresponding with those shown in valve assembly drawings.

■ Standard material configuration can be applied to sour service.

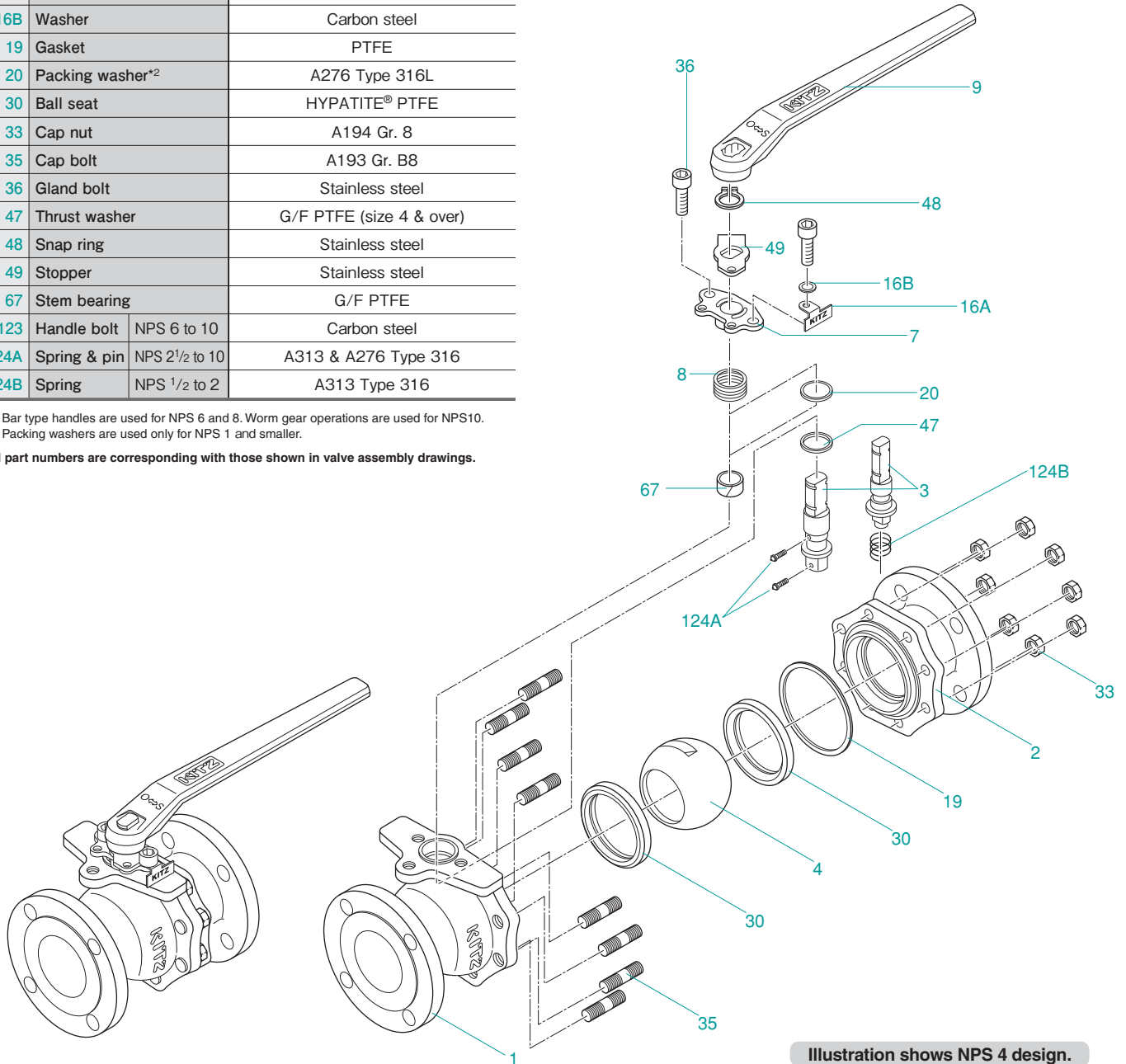

Illustration shows NPS 4 design.

## Construction and Materials

■ Standard material configuration can be applied to sour service.

No.	Parts	Standard	Fire-safe
		150UTAZM 300UTAZM	150UTAZM-FS 300UTAZM-FS
1	Body	A351 Gr. CF8M	
3	Stem	A276 Type 316	
4	Ball	A276 Type 316/A351 Gr. CF8M	
7	Gland	A351 Gr. CF8M	
8	Gland packing	PTFE	Flexible graphite
9	Handle*	Ductile iron	
9A	Handle bar	Carbon steel	
9B	Handle head	Ductile iron	
16A	Name plate	Stainless steel	
16B	Lev plate	Stainless steel	
19A	Gasket	PTFE	
19B	Gasket	—	Flexible graphite
20	Packing washer	A276 Type 316L	
29	Insert	A351 Gr. CF8M/A182 Gr. F316/A276 Type 316	
30	Ball seat	HYPATITE® PTFE	
36	Gland bolt	Stainless steel	
40	Key-lock plate	Stainless steel	
43	Handle-lock plate	Stainless steel	
48	Snap ring	Stainless steel	
49	Stopper	Stainless steel	
51	Stopper plate	Stainless steel	
57	Gland bush	G/F PTFE	
58	Gland washer	A276 Type 304	
67	Stem bearing	G/F PTFE	
123A	Handle lock plate bolt	Stainless steel	
123B	Handle bolt	Stainless steel	
124	Spring & pin	A313 & A276 Type 316	
126	Stopper plate bolt	Stainless steel	
145	Coned disc spring	Stainless steel	
216A	Ce plate	Stainless steel	
216B	Atex plate	Stainless steel	

\* Bar type handles are used for NPS 6 and larger.

All part numbers are corresponding with those shown in valve assembly drawings.

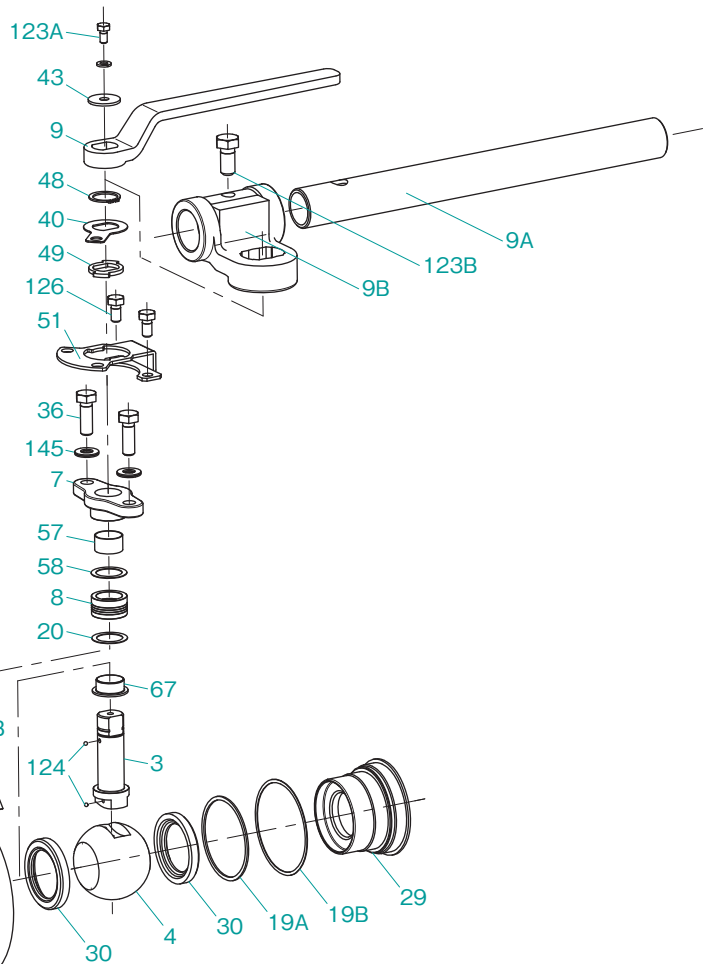

Regarding this specification, there are cases where it is not used. (16B, 19B, 216A, 216B)

Illustration shows NPS 1/2 design.

## Construction and Materials

No.	Parts	Standard		Fire-safe
		600UTB	600UTBM	600UTBS/UTBSM
1	Body	A351 Gr. CF8*2	A351 Gr. CF8M*2	A351 Gr. CF8/ CF8M*2
2	Body cap			
3	Stem			
4	Ball	A276 Type 304*2	A276 Type 316*2	A276 Type 304/316*2
7	Gland	A351 Gr. CF8		
8	Gland packing	PTFE		Flexible graphite
9	Handle	Ductile iron		
16	Name plate	Stainless steel		
19	Gasket*1	—		Flexible graphite spiral wound
20	Packing washer NPS 1/2 to 1	A276 Type 316L		
30	Ball seat	Reinforced PTFE with MoS2		
33	Cap nut	A194 Gr. 8		
35	Cap bolt	A193 Gr. B8		
36	Gland bolt	Stainless steel		
45A	O-ring	FKM		—
45B	O-ring	FKM		
47	Thrust washer	Metal-backed PTFE		
48	Snap ring	Stainless steel		
49	Stopper	Stainless steel		
67	Stem bearing	G/F PTFE		
124	Spring & pin	A313 & A276 Type 316		
143	Seat spring	A276 Type 304	INCONEL® X-750	A276 Type 304/ INCONEL® X-750
150	Seat retainer	A276 Type 304	A276 Type 316	A276 Type 304/316
155	Spacer*1	—		PTFE
175	Retainer gland*1	—		A276 Type 304
176	Retainer packing*1	—		Flexible graphite

\*1 This parts are used only for super-firesafe provision.

\*2 Other stainless steel are optionally available.

All part numbers are corresponding with those shown in valve assembly drawings.

■ Standard material configuration can be applied to sour service.

No.	Parts	Standard	Fire-safe
		600SCTB	600SCTBS
1	Body	A105*1	
2	Body cap		
3	Stem	A276 Type 304*2	
4	Ball		
7	Gland	A351 Gr. CF8	
8	Gland packing	PTFE	Flexible graphite
9	Handle	Ductile iron	
16	Name plate	Stainless steel	
19	Gasket*3	—	Flexible graphite spiral wound
20	Packing washer NPS 1/2 to 1	A276 Type 316L	
30	Ball seat	Reinforced PTFE with MoS2	
33	Cap nut	A194 Gr. 2H	
35	Cap bolt	A193 Gr. B7	
36	Gland bolt	Cr-Mo steel	
45A	O-ring	NBR	—
45B	O-ring	NBR	
47	Thrust washer	Metal-backed PTFE	
48	Snap ring	Carbon steel	
49	Stopper	Stainless steel	
67	Stem bearing	G/F PTFE	
124	Spring & pin	A313 & A276 Type 316	
143	Seat spring	A276 Type 304	
150	Seat retainer	A105 Zn plating	
155	Spacer*3	—	PTFE
175	Retainer gland*3	—	A105
176	Retainer packing*3	—	Flexible graphite

\*1 A350 low-temperature service materials are optionally available.

\*2 Type 316 and other stainless steels are optionally available for ball and stem.

\*3 These parts are used only for super-firesafe provision.

All part numbers are corresponding with those shown in valve assembly drawings.

■ An optional material configuration is available for sour service.

Refer to the illustration on Page 47.

## Construction and Materials

### ■ Class 600 Floating Ball Valve

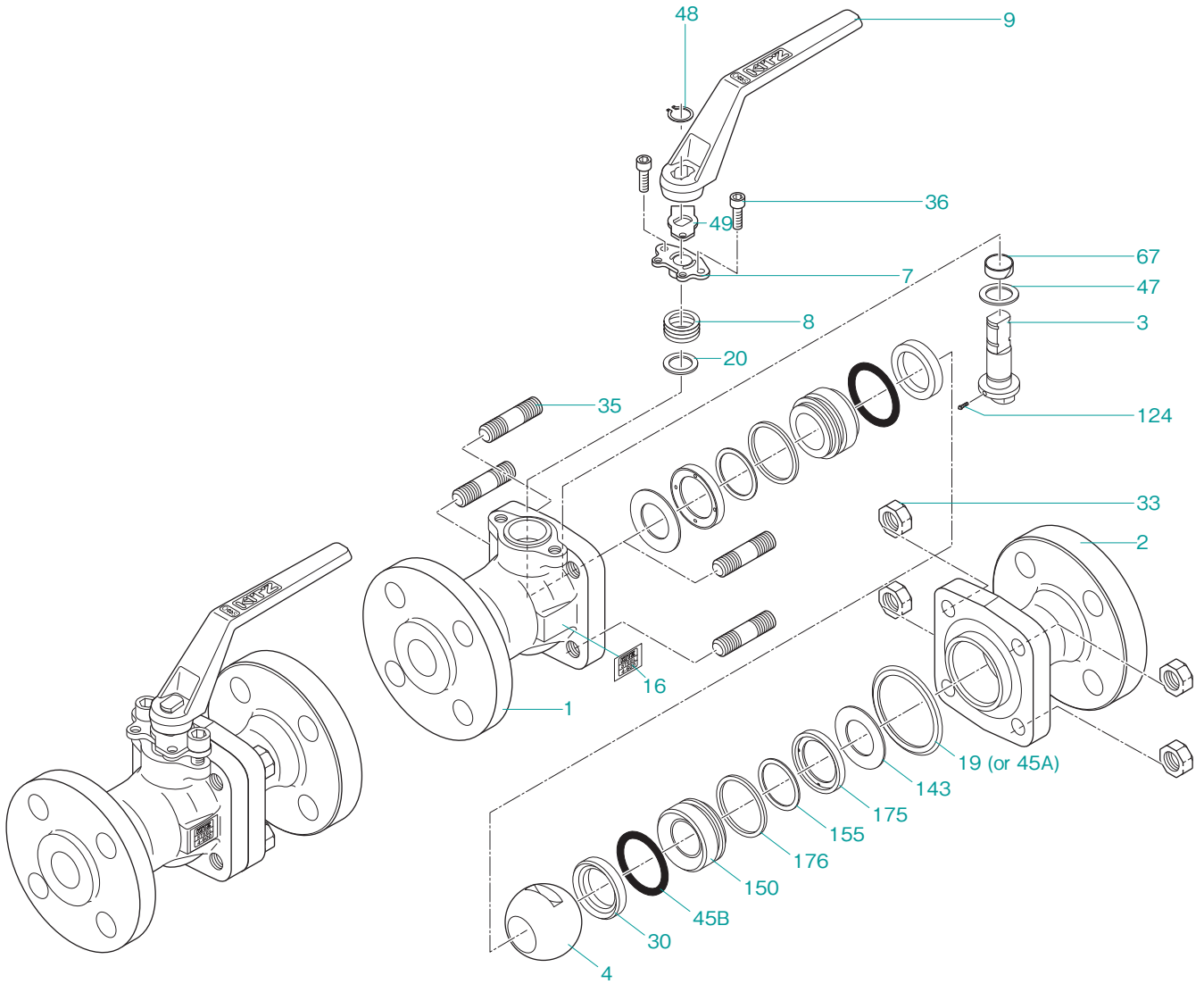

Illustration shows NPS 1/2 design.



## Construction and Materials

No.	Parts	Standard	
		1500UTB(S)	1500UTB(S)M
1	Body	A351 Gr. CF8*2	A351 Gr. CF8M*2
2	Body cap		
3	Stem	A276 Type 304*2	A276 Type 316*2
4	Ball		
7	Gland	A351 Gr. CF8	
8	Gland packing	PTFE	
9	Handle	Ductile iron	
19	Gasket*1	—	
30	Ball seat	Nylon with MoS2	
31	Stem washer	A276 Type 316	
33	Cap nut	A194 Gr. 8	
35	Cap bolt	A193 Gr.B8	
36	Grand bolt	Stainless steel	
45A	O-ring	FKM	
45B	O-ring	FKM	
47	Thrust washer	Metal-backed PTFE	
48	Snap ring	A276 Type 304	
49	Stopper	A276 Type 304	
67	Stem bearing	G/F PTFE	
85	Plug	A276 Type 316	
124	Spring & pin	A313 & A276 Type 316	
143	Seat spring	A276 Type 304	INCONEL® X-750
146	Back-up ring	PTFE	
150	Seat retainer	A276 Type 304	A276 Type 316
155	Spacer*1	PTFE	
175	Retainer gland*1	A276 Type 304	A276 Type 316
176	Retainer packing*1	Flexible graphite	

\*1 These parts are used only for super-firesafe provision.  
\*2 Other stainless steel are optionally available.

All part numbers are corresponding with those shown in valve assembly drawings.

■ Standard materials can be used for to sour service.

No.	Parts	Standard	Fire-safe
		1500SCTB	1500SCTBS
1	Body	A216 Gr. WCB*1	
2	Body cap		
3	Stem	A276 Type 304*2	
4	Ball		
7	Gland	A351 Gr. CF8	
8	Gland packing	PTFE	Flexible graphite
9	Handle	Ductile iron	
19	Gasket*3	—	Flexible graphite spiral wound
30	Ball seat	Nylon with MoS2	
31	Stem washer	A276 Type 316	
33	Cap nut	A194 Gr. 2H	
35	Cap bolt	A193 Gr. B7	
36	Gland bolt	Alloy steel	
45A	O-ring	NBR	—
45B	O-ring	NBR	
47	Thrust washer	Metal-backed PTFE	
48	Snap ring	Carbon steel	
49	Stopper	Stainless steel	
67	Stem bearing	G/F PTFE	
85	Plug	A576 Gr. 1025 Zn plating	
124	Spring & pin	A313 & A276 Type 316	
143	Seat spring	A276 Type 304	
146	Back-up ring	PTFE	
150	Seat retainer	A105 Zn plating	
155	Spacer*3	—	PTFE
175	Retainer gland*3	—	A105
176	Retainer packing*3	—	Flexible graphite

\*1 A352 low-temperature service materials are optionally available.  
\*2 Type 316 is optionally available for ball and stem.  
\*3 These parts are used only for fire-safe provision.

All part numbers are corresponding with those shown in valve assembly drawings.

■ Optional materials are available for sour service.

Refer to the illustration on Page 49.

## Construction and Materials

### ■ Class 1500 Floating Ball Valve

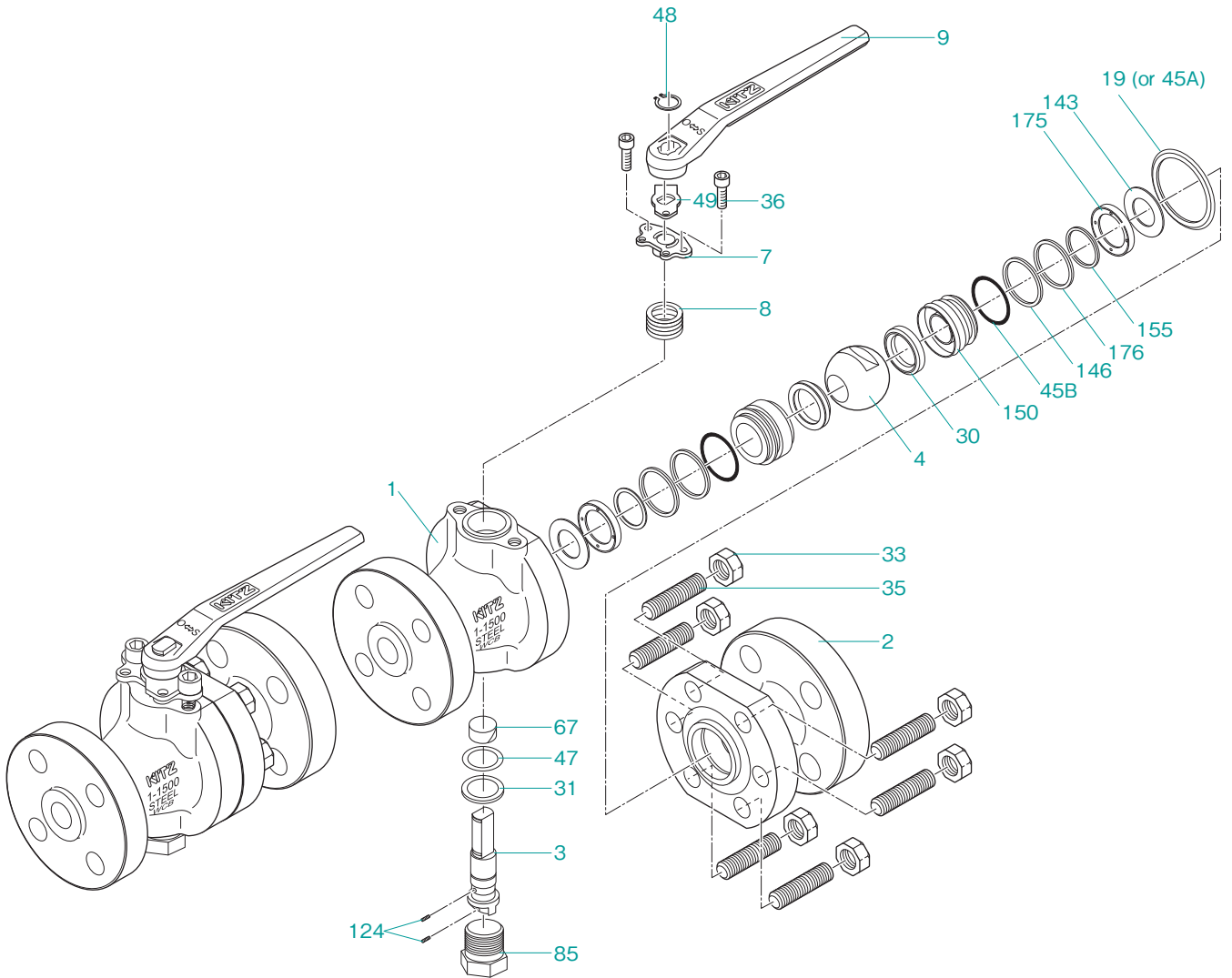

# Λ (Lambda)-Port® Control Valves

## Design Features

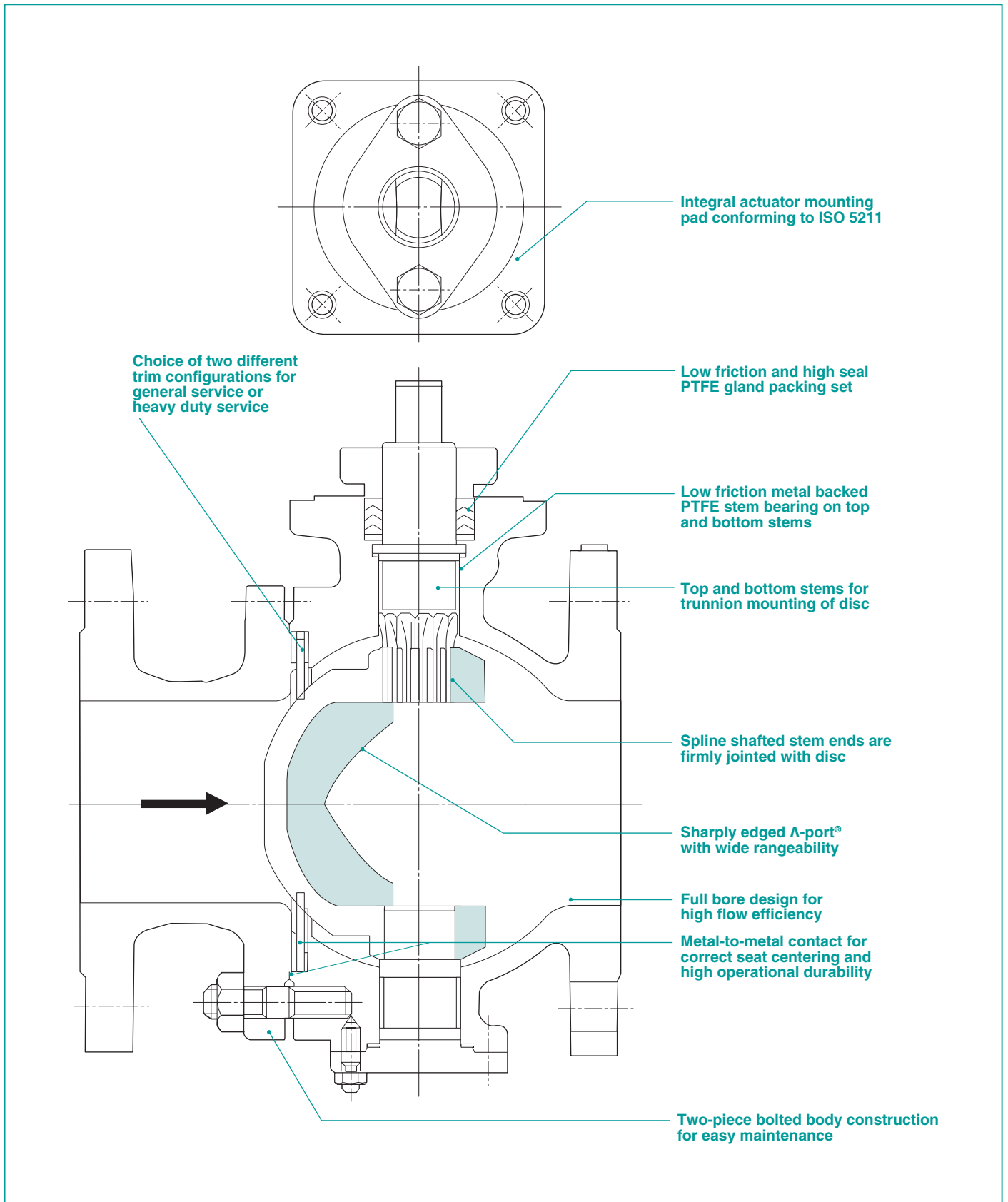

## Design Features

### 1. Sharp solid cutting

A trunnion mounted disc is sharply edged for cutting solids and fibrous objects mixed in line fluids, preventing disturbance to valve closing operation, and minimizing fluid residue within the valve bore.



### 2. Choice of trims

Choice of two different trim configurations is available, depending on the planned service condition:

**FLEKSEAT**, made of spring Steel Type 316, provides elasticity in its contact with the hard-chromium plated CF8M disc for higher sealing performance. This seat is recommended for pulp and paper mill process control and services where higher sealing performance is critically required on valve shut-off. This seat is suited for throttling service. (KITZ Fig. UVG)

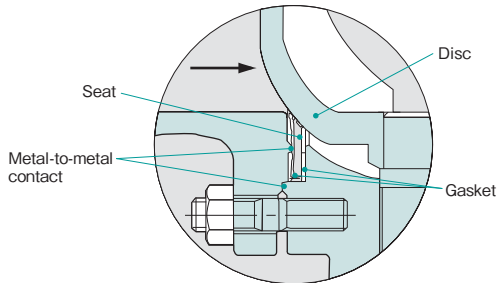

**KNIFESEAT**, made of Stellite deposited steel Type 316, contacts hard-chromium plated CF8M disc for heavy duty services. This seat is recommended for slurry service, and all other abrasion services. Also good for high viscosity services including pulp and paper mill processes. It is also recommended for throttling service. (KITZ Fig. UVCT)

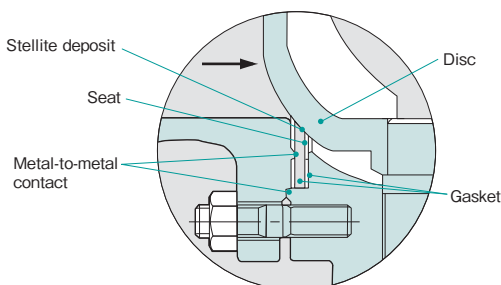

### 3. Structural reliability

Metal-to-metal contact is accommodated between body and cap, and between seat and cap, for correct seat centering and adequate depressing force. Spline shafted stem ends are firmly jointed with the disc for correct disc centering and higher operational durability. In addition, trunnion mounting of the disc on the body helps increase total structural reliability of the valve against extraordinary piping stress.

### 4. Stabilized operating torque

Metal backed PTFE stem bearings are employed on top and bottom stems for minimized and stabilized torque of valve operation. Fine finish of the disc surface and other sliding surfaces of components also helps smooth operation of the valve.

### 5. Maintenance ease

Two-Piece split body construction provides the convenience of easy maintenance which is always critically required for handling viscous or fibrous line fluids.

### 6. High flow efficiency

Full bore design guarantees maximized and linear flow characteristics with minimized pressure loss, helping viscous or fibrous line fluids pass through the valve bore smoothly.

### 7. Valve automation

Quarter-turn valve drive mechanism enables technically easier mounting of valve automation measures such as electric and pneumatic actuators. Integral pads are provided for easy, safe and assured on-the-spot actuator mounting without disassembly of valve glands, as required by ISO standard.

Note: Customers are requested to prepare mounting brackets and connectors chosen for their valve actuation as illustrated here.

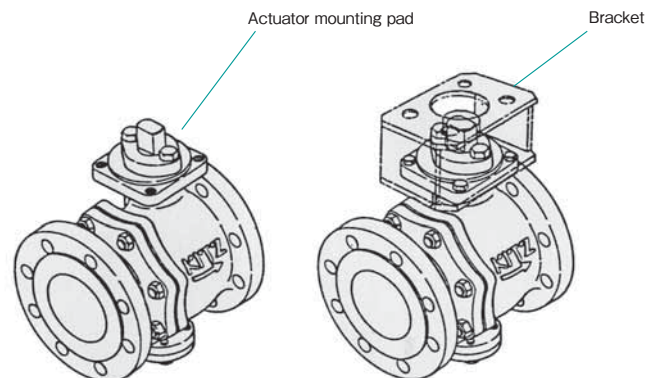

**Caution:** KITZ  $\Lambda$ -port® control valves are designed for uni-directional flow control. Be sure to mount the valve correctly so that the direction of line flow matches the direction of the arrow mark cast on the valve body.

## Design Data

### Design Specifications

Valve structure	Split body side entry, RF-flanged, full bore, trunnion mounted disc
Wall thickness	ASME B16.34 Class 150/Class 300
F-F dimensions	JIS B2002 or ASME B16.10 Class 150/Class 300 for ball valves
End connection	RF-flanged to JIS B2220 10K/20K or ASME B16.5 Class 150/Class 300
Actuator mounting pad	ISO 5211
P-T rating	JIS B2220 10K/20K or ASME B16.34 Class 150/Class 300
Operation	Quarter-turn

### Test Pressure

Seat test Hydrostatic or pneumatic at 0.39 MPa (4 kgf/cm <sup>2</sup> or 60 psi)	FLEKSEAT for general service	Allowable leakage 0.0005% of Nominal Cv to IEC 534-4 Class IV-SI or ANSI FCI 70-2 Class IV × 0.05
	KNIFESEAT for heavy duty service	Allowable leakage 0.5% of Nominal Cv to IEC 534-4 Class II or ANSI FCI 70-2 Class II

### Maximum Allowable Seat Leakage {Per minute under 0.4 MPa test pressure}

Nominal Size		FLEKSEAT (UVC)			KNIFESEAT (UVCT)	
NPS	DN	Cv at full opening	Hydrostatic (cc/min)	Pneumatic (NL/min)	Cv at full opening	Hydrostatic (L/min)
1	25	25	3.6	1.08	31	4.45
1½	40	85	12.2	3.66	100	14.4
2	50	145	20.8	6.24	160	23.0
2½	65	240	34.5	10.35	265	38.1
3	80	380	54.6	16.38	400	57.5
4	100	550	79.0	23.70	585	84.1
5	125	960	138	41.40	1010	145
6	150	1500	216	46.80	1550	223
8	200	2700	388	116.40	2750	395
10	250	4300	618	185.40	4400	632
12	300	6200	891	267.30	6300	905
14	350	8200	1178	353.40	8300	1193

Condition: Absolute air pressure 0.1 MPa at 20°C

## Class 150/10K Lever Operated $\Lambda$ -port® Control Valves

### Trim

FLEKSEAT  
KNIFESEAT

### ASME Class 150

L-150UVC(M)  
L-150UVCT(M)

### 10K

L-10UVC(M)  
L-10UVCT(M)

In case of CF8M valve body, KITZ Fig. shall be suffixed with "M".

Page 101 for Pressure-Temperature Ratings.

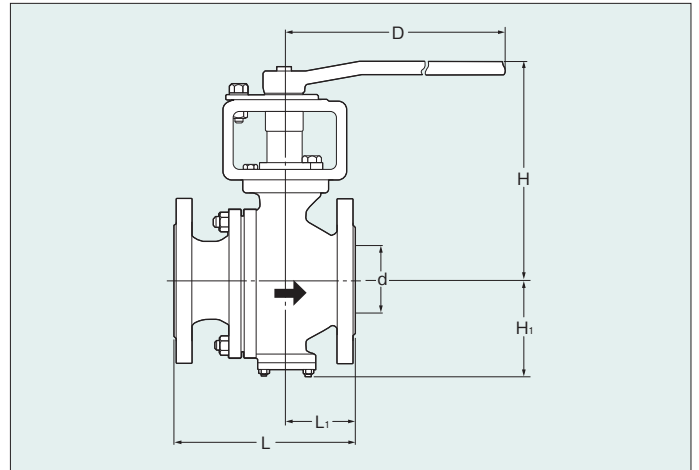

### Dimensions of L-150UVC(M), L-150UVCT(M), L-10UVC(M), L-10UVCT(M)

Unit: mm

Nominal Size	NPS	1	1½	2	2½	3	4	5	6	8
	DN	25	40	50	65	80	100	125	150	200
d		25	38	51	64	76	102	127	152	203
L		127	165	178	190	203	229	356	394	457
L <sub>1</sub>		48	67	69	76	77	89	158	197	228.5
H		181	198	204	245	252	283	305.5	392	460
H <sub>1</sub>		68.5	76	84.5	97	106	133.5	157	182	226.5
D		160	230	230	400	400	460	460	1000	1500

Refer to "Product Range" on Page 4.

## Class 150/10K Gear Operated $\Lambda$ -port® Control Valves

### Trim

FLEKSEAT  
KNIFESEAT

### ASME Class 150

G-150UVC(M)  
G-150UVCT(M)

### 10K

G-10UVC(M)  
G-10UVCT(M)

In case of CF8M valve body, KITZ Fig. shall be suffixed with "M".

Page 101 for Pressure-Temperature Ratings.

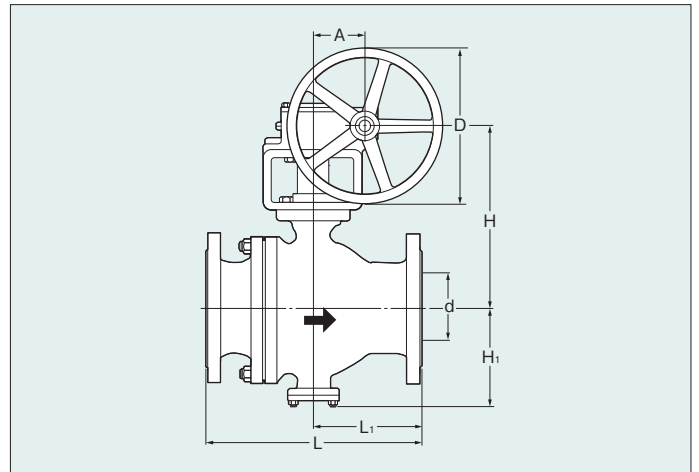

### Dimensions of G-150UVC(M), G-150UVCT(M), G-10UVC(M), G-10UVCT(M)

Unit: mm

Nominal Size	NPS	6	8	10	12	14
	DN	150	200	250	300	350
d		152	203	254	305	337
L		394	457	533	610	686
L <sub>1</sub>		197	228.5	266.5	260	293
H		330	410	446	524	547.5
H <sub>1</sub>		182	226.5	268.5	365.5	403.5
D		310	360	500	500	500
A		65.5	88.5	93.5	134	134

Refer to "Product Range" on Page 4.

## Class 300/20K Lever Operated $\Lambda$ -port® Control Valves

### Trim

**FLEKSEAT**  
**KNIFESEAT**

### ASME Class 300

**L-300UVC(M)**  
**L-300UVCT(M)**

### 20K

**L-20UVC(M)**  
**L-20UVCT(M)**

In case of CF8M valve body, KITZ Fig. shall be suffixed with "M".

Page 101 for Pressure-Temperature Ratings.

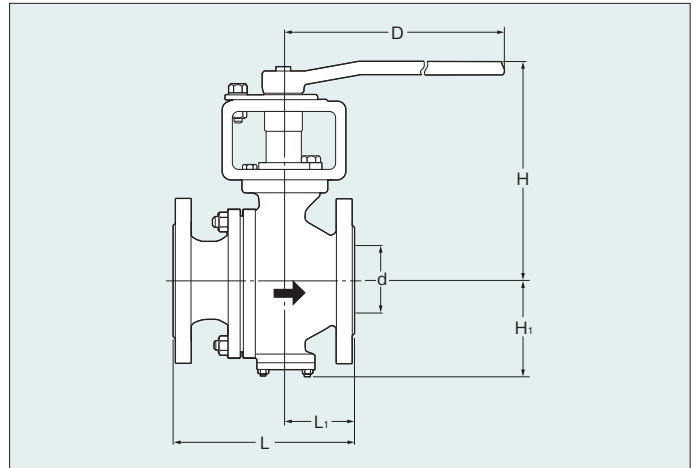

### Dimensions of L-300UVC(M), L-300UVCT(M), L-20UVC(M), L-20UVCT(M)

Unit: mm

Nominal Size	NPS	1	1½	2	2½	3	4	5	6	8
	DN	25	40	50	65	80	100	125	150	200
d		25	38	51	64	76	102	127	152	203
L		165	190	216	241	283	305	381	403	502
L <sub>1</sub>		68	73.5	87.5	102	120.5	125	158	182	228.5
H		181	198	204	245	252	283	305.5	392	460
H <sub>1</sub>		72	79	88	100	109	135	157	182	226.5
D		160	230	230	400	400	460	460	1000	1500

Refer to "Product Range" on Page 4.

## Class 300/20K Gear Operated $\Lambda$ -port® Control Valves

### Trim

**FLEKSEAT**  
**KNIFESEAT**

### ASME Class 300

**G-300UVC(M)**  
**G-300UVCT(M)**

### 20K

**G-20UVC(M)**  
**G-20UVCT(M)**

In case of CF8M valve body, KITZ Fig. shall be suffixed with "M".

Page 101 for Pressure-Temperature Ratings.

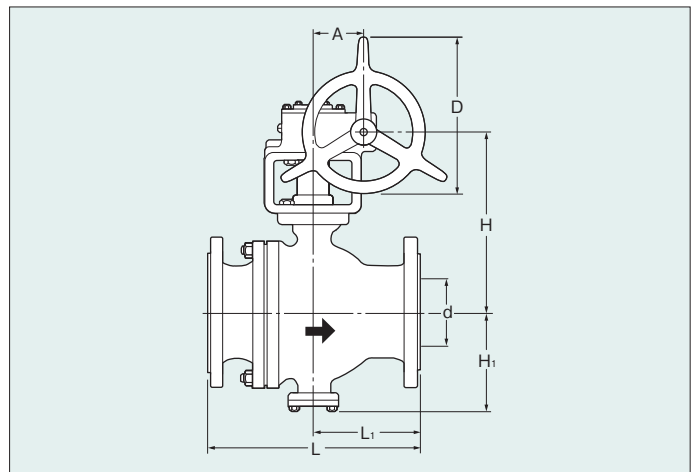

### Dimensions of G-300UVC(M), G-300UVCT(M), G-20UVC(M), G-20UVCT(M)

Unit: mm

Nominal Size	NPS	6	8	10
	DN	150	200	250
d		152	203	254
L		403	502	568
L <sub>1</sub>		182	228.5	242.5
H		330	410	446
H <sub>1</sub>		182	226.5	268.5
D		310	360	500
A		65.5	88.5	93.5

Refer to "Product Range" on Page 4.



# T60S Soft Seated 3-Piece Body Trunnion Mounted Ball Valves

## Component Drawing

### Up to NPS 4

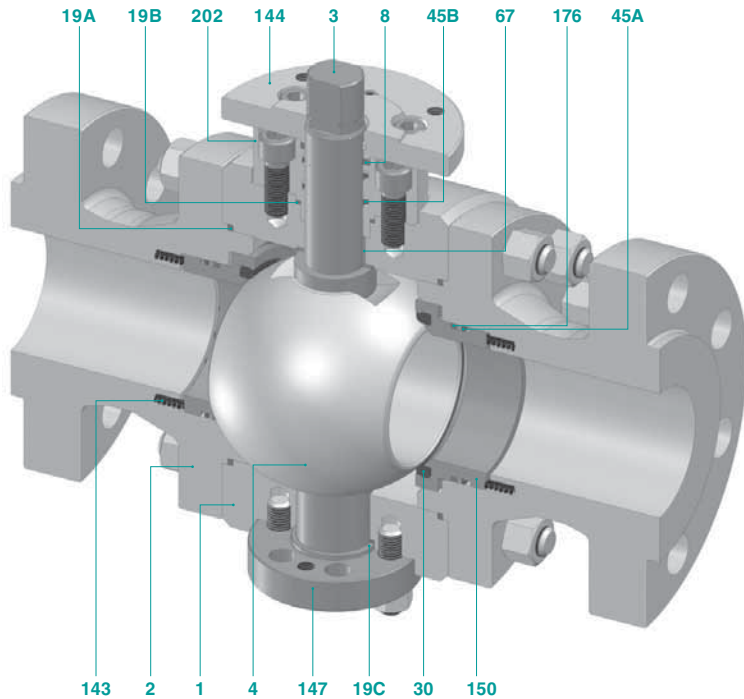

- 1 Body\*
- 2 Cap\*
- 3 Stem
- 4 Precision machined ball
- 8 Fire-safe gland packing (Flexible graphite)
- 19A Gasket (Flexible graphite)
- 19B Gasket (Flexible graphite)
- 19C Gasket (Flexible graphite)
- 30 Ball seat
- 45A O-ring
- 45B O-ring
- 67 Stem bearing (Metal + R-PTFE)
- 143 Seat spring
- 144 Gland plate
- 147 End plate
- 150 Seat retainer
- 176 Fire-safe retainer packing (Flexible graphite)
- 202 Bonnet

\*Note: Made of forged carbon steel, low alloy steel and high alloy steel. Made of forged or cast austenitic stainless steel, duplex stainless steel and other special alloy materials. Contact KITZ for current available materials.

### NPS 6 and over

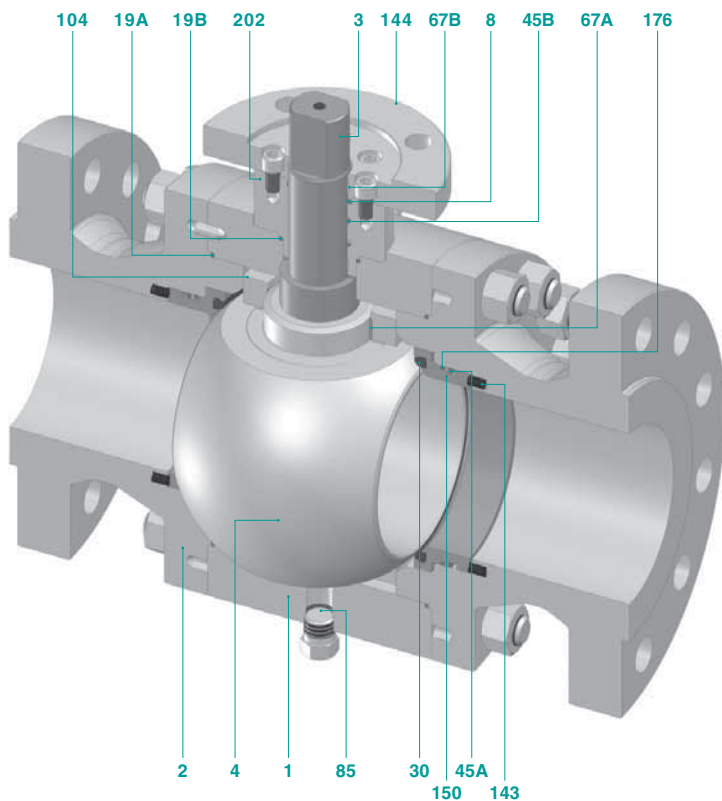

- 1 Body\*
- 2 Cap\*
- 3 Stem
- 4 Precision machined ball
- 8 Fire-safe gland packing (Flexible graphite)
- 19A Gasket (Flexible graphite)
- 19B Gasket (Flexible graphite)
- 30 Ball seat
- 45A O-ring
- 45B O-ring
- 67A Curl bearing (Metal + R-PTFE)
- 67B Stem bearing (PTFE)
- 85 Plug
- 104 Trunnion plate
- 143 Seat spring
- 144 Gland plate
- 150 Seat retainer
- 176 Fire-safe retainer packing (Flexible graphite)
- 202 Bonnet

\*The illustration shown in this catalog represents the typical structure of Class 600 valves.

The structure may differ depending on sizes and classes. Please consult KITZ for more details on the specifications and structure of the valve.

## Design Features

### 1. Fire-safe Design

#### (1) Internal Leakage Prevention

When resilient sealing materials are damaged or decomposed by a plant fire, edges of upstream and downstream metal seat retainers preloaded by seat springs come into contact with the ball to shut off line fluid to minimize internal leakage through the valve bore. Meanwhile, flexible graphite seat retainer packing rings of KITZ original design prevent fluid leakage from between the valve caps and seat retainers during and after the plant fire.

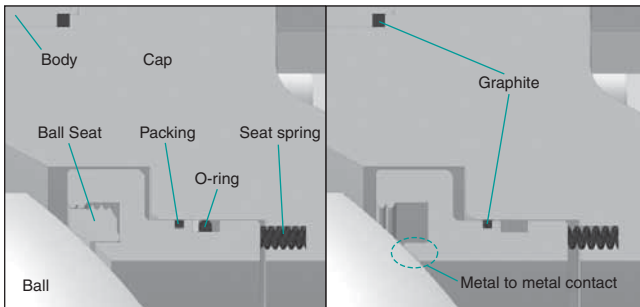

#### (2) External Leakage Prevention

External leakage from the valve stem area is prevented by double sealing with O-ring and flexible graphite gland packing ring. Leakage through the valve body joint is protected by flexible graphite gaskets. Even after a fire has deteriorated O-rings, flexible graphite gland packing ring and gaskets remain being the measure to prevent external fluid leakage.

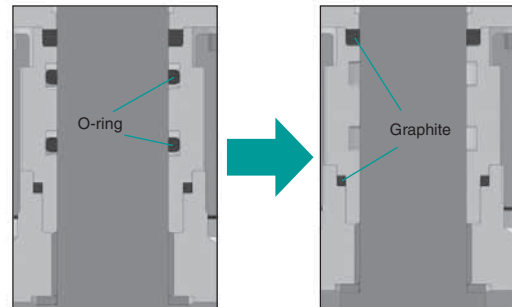

### 2. Tight Shut-off Sealing Mechanism

The resilient seat design adequately maintains each of the upstream and downstream ball seats in contact with the ball by means of repulsing force of seat springs inserted behind the seat retainers. Line fluid pressure also helps this contact method. This sealing mechanism features un failing thru-the-bore sealing performance of upstream and downstream side ball seats at the same time.

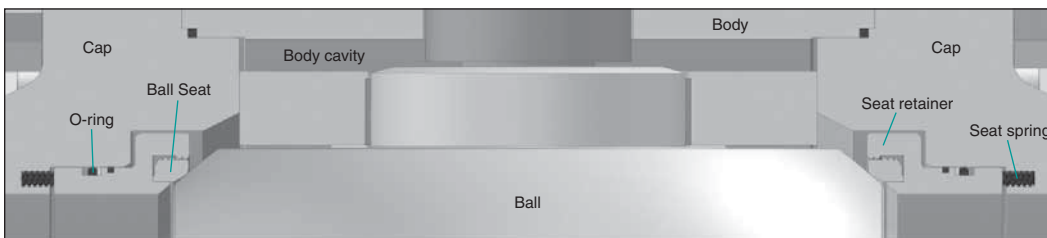

### 3. Double Block and Bleed Function

Ball seats may independently shut off the line fluid on the upstream and downstream side of the ball. The valve bore and the body cavity are isolated from each other when the valve is fully open or closed. Under this condition, the cavity pressure can be discharged with a vent valve and a drain plug. The vent valve is equipped with a blowout-proof bleeder for safe discharge. Relieving the cavity pressure with a vent valve is recommended for safe draining.

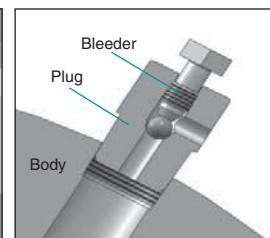

## Design Features

### 4. Blowout-proof Ball Seat Assembly

As illustrated below, ball seats are threaded into unthreaded back rooms of seat retainers to finally reach to inner walls and lower shoulders of the seat retainers for tightly sealing surface-to-surface contact. This unique design provides easy maintenance and blowout-proof seat assembly when ball seats are excessively loaded by back pressure due to incidental cavity pressure rise. (PATENT PENDING)

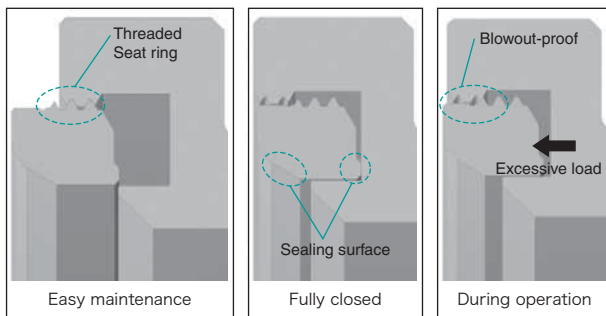

### 6. Cavity Pressure Relief

In case of incidental rise of servicing or ambient temperature, liquefied gas or highly volatile liquid trapped within the body cavity may evaporate, and cause an excessive rise in the cavity pressure. For safety consideration, when the cavity pressure exceeds the line pressure, either one of the ball seats will move slightly away from the ball surface together with seat retainers to relieve the excessive cavity pressure into the valve bore.

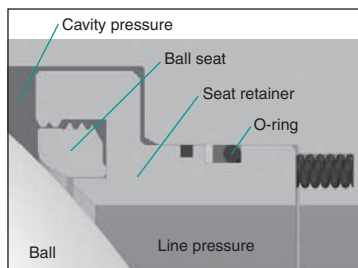

### 7. Low Emission Guaranteed Design

The fugitive emission suppressing design for both resilient and metal seated valves are certified to ISO 15848 tightness class "B" (Lower than  $10^{-4}$  mg·s<sup>-1</sup>·m<sup>-1</sup> for stem leakage and lower than 50 ppmv for body leakage). This verifies the outstanding low emission performance of the whole sealing mechanism of the valve.

### 5. Antistatic Design

Spring loaded balls assembled between the stem and the bonnet and between the stem and the ball permits electric conductivity through all metallic valve components.

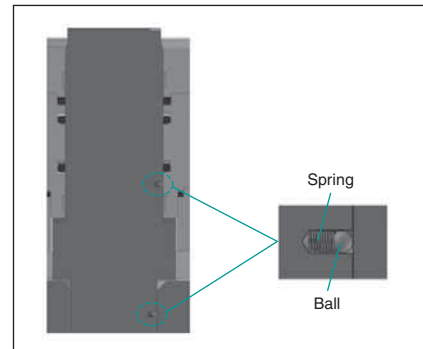

### 8. Options\*

#### (1) Emergency Seal Restoration

For accidental leakage from ball seats or stem sealing area, a sealant supply mechanism may be provided as an option. Should sealing materials be damaged or decomposed by a fire or other accidental causes, leakage can be temporarily prevented or reduced by sealant injection into this mechanism.

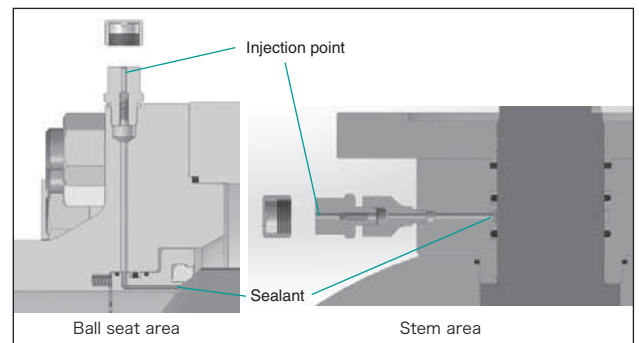

- (2) Special Shell and Trim Materials
- (3) Special Sealing Component Materials
- (4) Butt-welding Piping Connection
- (5) Pipe Pups Welded on Valve Ends
- (6) DIB: Double Isolation and Bleed (Double Seal)
- (7) Stem Extension
- (8) Overlay
- (9) Actuation (Pneumatic and Electric)

\*For all optional provisions, please contact your local KITZ agents or distributors.

# T60M Metal Seated 3-Piece Body Trunnion Mounted Ball Valves

## Component Drawing

### Up to NPS 4

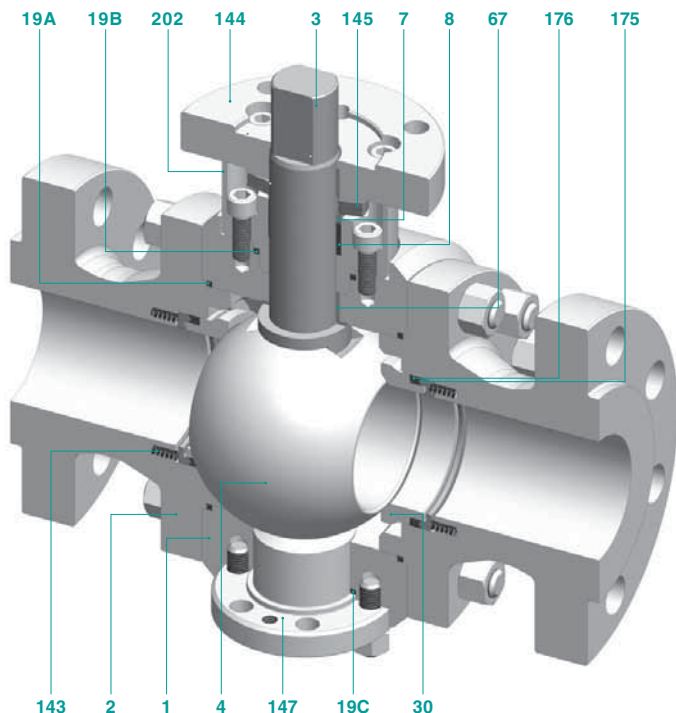

- 1 Body\*
- 2 Cap\*
- 3 Stem
- 4 Precision machined ball
- 7 Gland
- 8 Gland packing (Flexible graphite)
- 19A Gasket (Flexible graphite)
- 19B Gasket (Flexible graphite)
- 19C Gasket (Flexible graphite)
- 30 Ball seat
- 67 Stem bearing
- 143 Seat spring
- 144 Gland plate
- 145 Coned disc spring
- 147 End plate
- 175 Retainer gland
- 176 Seat packing (Flexible graphite)
- 202 Bonnet

\*Note: Made of forged carbon steel, low alloy steel and high alloy steel. Made of forged or cast austenitic stainless steel, duplex stainless steel and other special alloy materials. Contact KITZ for current available materials.

### NPS 6 and over

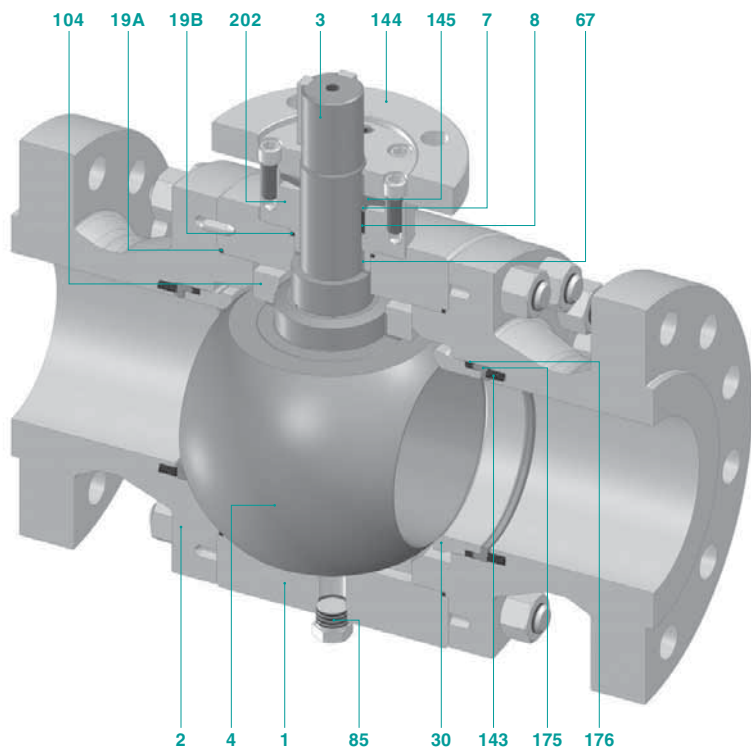

- 1 Body\*
- 2 Cap\*
- 3 Stem
- 4 Precision machined ball
- 7 Gland
- 8 Gland packing (Flexible graphite)
- 19A Gasket (Flexible graphite)
- 19B Gasket (Flexible graphite)
- 30 Ball seat
- 67 Stem bearing
- 85 Plug
- 104 Trunnion plate
- 143 Seat spring
- 144 Gland plate
- 145 Coned disc spring
- 175 Retainer gland
- 176 Seat packing (Flexible graphite)
- 202 Bonnet

\*The illustration shown in this catalog represents the typical structure of Class 600 valves. The structure may differ depending on sizes and classes. Please consult KITZ for more details on the specifications and structure of the valve.

## Design Features

### 1. Tight Shut-off Sealing Mechanism

The metal seat design, as the resilient seat design does, adequately maintains each of the upstream and downstream ball seats in contact with the ball by means of repulsing force of seat springs inserted behind seat retainers. Line fluid pressure also helps this contact method. This sealing mechanism features unfailing thru-the-bore sealing performance of upstream and downstream side ball seats at the same time. And surfaces of the ball and ball seats in contact are thermally sprayed with high alloy material. This provides higher wear resistance and durability for high temperature and abrasive services.

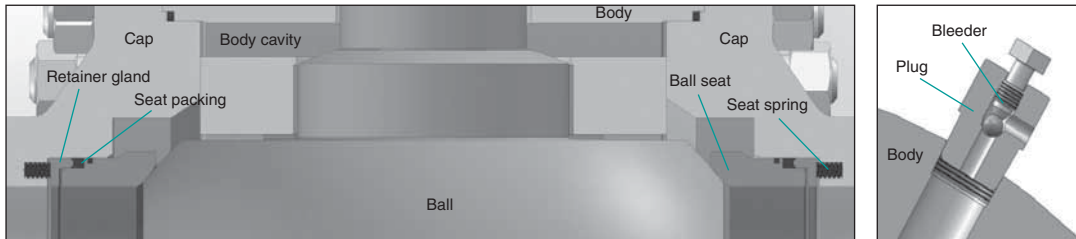

### 2. Double Block and Bleed Function

Ball seats may independently shut off the line fluid on the upstream and downstream side of the ball. The valve bore and the body cavity are isolated from each other when the valve is fully open or closed. Under this condition, the cavity pressure can be discharged with a vent valve and a drain plug. The vent valve is equipped with a blowout-proof bleeder for safe discharge. Relieving the cavity pressure with a vent valve is recommended for safe draining.

### 3. High Performance Seat Packing

The unique graphite seat packing rings with retainer glands provides reliable shut-off sealing performance during the entire service life. (PATENT PENDING)

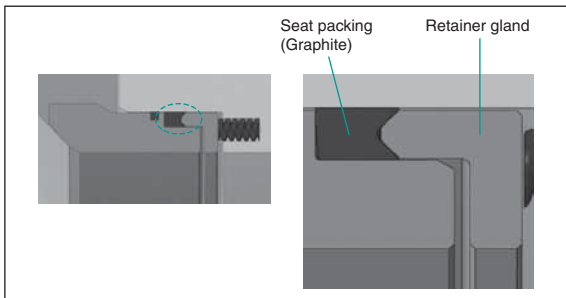

### 4. Live Loaded Packing Structure

The gland packing ring is compressed with a coned disc spring to prevent stress relaxation. This live loaded packing system provides highly durable sealing performance with no need of packing retightening.

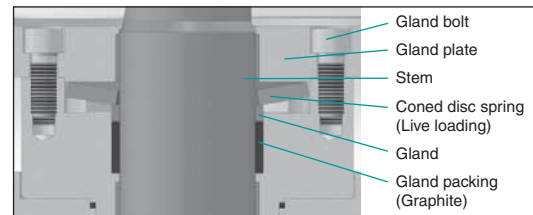

### 5. Cavity Pressure Relief

### 6. Low Emission Design

Please refer to Page 57.

### 7. Options

- (1) Special Shell and Trim Materials
- (2) Special Sealing Component Materials
- (3) Butt-welding Piping Connection
- (4) Pipe Pups Welded on Valve Ends
- (5) Stem Extension
- (6) Overlay
- (7) Actuation (Pneumatic and Electric)

\*For all optional provisions, please contact your local KITZ agents or distributors.

## Class 150 Stainless Steel/Carbon Steel Ball Valves

### 3-Piece body, Side entry design

**T60S/(G)-150UF3TCSM**  
(Full Bore)

**T60S/(G)-150SF3TCS**  
(Full Bore)

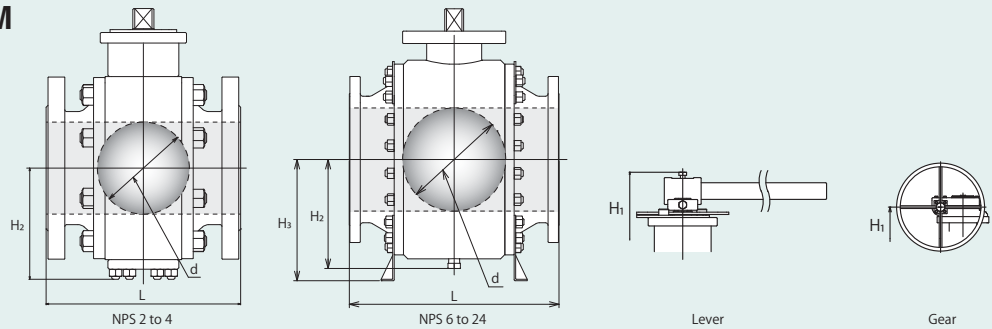

Dimensions of T60S/(G)-150UF3TCSM, T60S/(G)-150SF3TCS

Page 95 for Pressure-Temperature Ratings.

Nominal Size	NPS DN	2	3	4	6	8	10	12	14	16	18	20	24	
		50	80	100	150	200	250	300	350	400	450	500	600	
Valve operator		Lever					Gear							
Ball bore	in.	1.94	2.94	3.94	5.94	7.94	9.94	11.94	13.19	15.19	17.19	19.19	23.19	
	mm	49	74	100	150	201	252	303	334	385	436	487	589	
L	in.	7.00	8.00	9.00	15.50	18.00	21.00	24.00	27.00	30.00	34.00	36.00	42.00	
	mm	178	203	229	394	457	533	610	686	762	864	914	1067	
H <sub>1</sub>	in.	6.26	7.91	10.24	12.83	12.44	14.65	15.94	17.24	19.76	21.34	23.78	27.13	
	mm	159	201	260	326	316	372	405	438	502	542	604	689	
H <sub>2</sub>	in.	3.78	4.61	5.83	7.44	8.98	10.98	-	-	-	-	-	-	
	mm	96	117	148	189	228	279	-	-	-	-	-	-	
H <sub>3</sub>	in.	-	-	-	-	-	-	16.18	17.13	18.18	20.12	21.97	25.20	
	mm	-	-	-	-	-	-	411	435	477	511	558	640	

Refer to "Product Range" on Page 6.

## Class 150 Stainless Steel/Carbon Steel Ball Valves

### 3-Piece body, Side entry design

**T60S/(G)-150UF3TCRSM**  
(Reduced Bore)

**T60S/(G)-150SF3TCRS**  
(Reduced Bore)

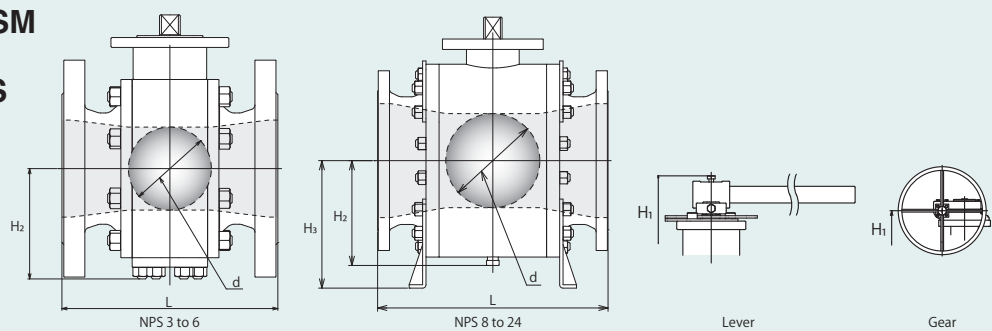

Dimensions of T60S/(G)-150UF3TCRSM, T60S/(G)-150SF3TCRS

Page 95 for Pressure-Temperature Ratings.

Nominal Size	NPS DN	3	4	6	8	10	12	14	16	18	20	24	
		80	100	150	200	250	300	350	400	450	500	600	
Valve operator		Lever					Gear						
Ball bore	in.	1.94	2.94	3.94	5.94	7.94	9.94	11.94	13.19	15.19	17.19	19.19	
	mm	49	74	100	150	201	252	303	334	385	436	487	
L	in.	8.00	9.00	15.50	18.00	21.00	24.00	27.00	30.00	34.00	36.00	42.00	
	mm	203	229	394	457	533	610	686	762	864	914	1067	
H <sub>1</sub>	in.	6.26	7.91	10.24	12.83	12.40	14.65	15.94	17.24	17.76	22.05	24.33	
	mm	159	201	260	326	315	372	405	438	502	560	618	
H <sub>2</sub>	in.	3.78	4.57	5.67	7.44	8.94	10.98	-	-	-	-	-	
	mm	96	116	144	189	227	279	-	-	-	-	-	
H <sub>3</sub>	in.	-	-	-	-	-	-	16.18	17.13	18.78	20.47	22.48	
	mm	-	-	-	-	-	-	411	435	477	520	571	

## Class 300 Stainless Steel/Carbon Steel Ball Valves

### 3-Piece body, Side entry design

**T60S/(G-)300UF3TCSM**  
(Full Bore)

**T60S/(G-)300SF3TCS**  
(Full Bore)

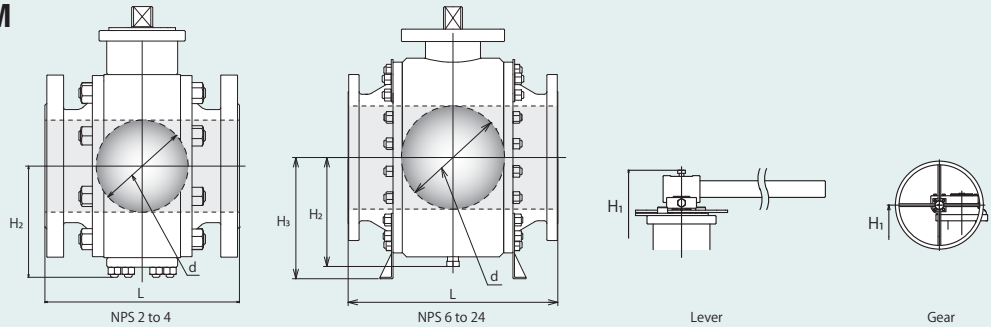

Dimensions of T60S/(G-)300UF3TCSM, T60S/(G-)300SF3TCS

Page 95 for Pressure-Temperature Ratings.

Nominal Size	NPS DN	2 50	3 80	4 100	6 150	8 200	10 250	12 300	14 350	16 400	18 450	20 500	24 600
Valve operator		Lever					Gear						
Ball bore	in.	1.94	2.94	3.94	5.94	7.94	9.94	11.94	13.19	15.19	17.19	19.19	23.19
	mm	49	74	100	150	201	252	303	334	385	436	487	589
L	in.	8.50	11.13	12.00	15.88	19.75	22.38	25.50	30.00	33.00	36.00	39.00	45.00
	mm	216	283	305	403	502	568	648	762	838	914	991	1143
H <sub>1</sub>	in.	6.26	7.91	10.24	12.83	12.44	14.65	16.26	17.24	19.76	21.34	23.78	27.48
	mm	159	201	260	326	316	372	413	438	502	542	604	698
H <sub>2</sub>	in.	3.78	4.57	5.67	7.44	8.98	10.98	-	-	-	-	-	-
	mm	96	116	144	189	228	279	-	-	-	-	-	-
H <sub>3</sub>	in.	-	-	-	-	-	-	16.18	17.13	18.78	20.12	21.97	27.48
	mm	-	-	-	-	-	-	411	435	477	511	558	698

## Class 300 Stainless Steel/Carbon Steel Ball Valves

### 3-Piece body, Side entry design

**T60S/(G-)300UF3TCRSM**  
(Reduced Bore)

**T60S/(G-)300SF3TCRS**  
(Reduced Bore)

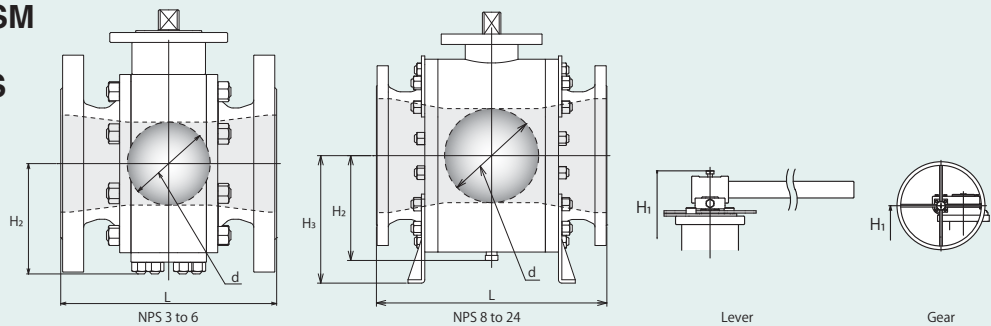

Dimensions of T60S/(G-)300UF3TCRSM, T60S/(G-)300SF3TCRS

Page 95 for Pressure-Temperature Ratings.

Nominal Size	NPS DN	3 80	4 100	6 150	8 200	10 250	12 300	14 350	16 400	18 450	20 500	24 600	
Valve operator		Lever					Gear						
Ball bore	in.	1.94	2.94	3.94	5.94	7.94	9.94	11.94	13.19	15.19	17.19	19.19	
	mm	49	74	100	150	201	252	303	334	385	436	487	
L	in.	11.13	12.00	15.88	19.75	22.38	25.50	30.00	33.00	36.00	39.00	45.00	
	mm	283	305	403	502	568	648	762	838	914	991	1143	
H <sub>1</sub>	in.	6.26	7.91	10.24	12.83	12.40	14.65	16.26	17.24	19.76	22.05	24.33	
	mm	159	201	260	326	315	372	413	438	502	560	618	
H <sub>2</sub>	in.	3.78	4.57	5.67	7.44	8.94	10.98	-	-	-	-	-	
	mm	96	116	144	189	227	279	-	-	-	-	-	
H <sub>3</sub>	in.	-	-	-	-	-	-	16.18	17.13	18.78	20.47	22.48	
	mm	-	-	-	-	-	-	411	435	477	520	571	



## Class 600 Stainless Steel/Carbon Steel Ball Valves

### 3-Piece body, Side entry design

**T60S/(G)-600UF3TCSM**  
(Full Bore)

**T60S/(G)-600SF3TCS**  
(Full Bore)

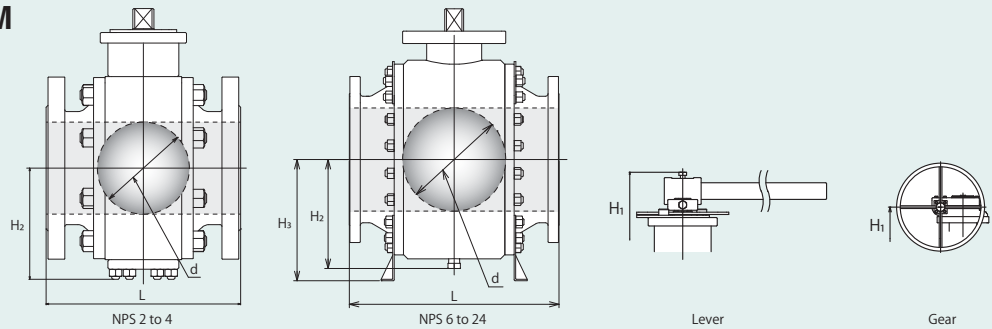

Dimensions of T60S/(G)-600UF3TCSM, T60S/(G)-600SF3TCS

Page 95 for Pressure-Temperature Ratings.

Nominal Size	NPS DN	2	3	4	6	8	10	12	14	16	18	20	24
		50	80	100	150	200	250	300	350	400	450	500	600
Valve operator		Lever						Gear					
Ball bore	in.	1.94	2.94	3.94	5.94	7.94	9.94	11.94	13.19	15.19	17.19	19.19	23.19
	mm	49	74	100	150	201	252	303	334	385	436	487	589
L	in.	11.50	14.00	17.00	22.00	26.00	31.00	33.00	35.00	39.00	43.00	47.00	55.00
	mm	292	356	432	559	660	787	838	889	991	1092	1194	1397
H <sub>1</sub>	in.	7.17	9.29	10.35	11.1	13.43	15.28	17.76	18.82	21.06	23.27	25.39	29.76
	mm	182	236	263	282	341	388	451	478	535	591	645	756
H <sub>2</sub>	in.	3.86	4.76	5.91	7.72	9.69	-	-	-	-	-	-	-
	mm	98	121	150	196	246	-	-	-	-	-	-	-
H <sub>3</sub>	in.	-	-	-	-	-	15.28	16.77	17.68	19.53	20.98	23.07	26.42
	mm	-	-	-	-	-	388	426	449	496	533	586	671

## Class 600 Stainless Steel/Carbon Steel Ball Valves

### 3-Piece body, Side entry design

**T60S/(G)-600UF3TCRSM**  
(Reduced Bore)

**T60S/(G)-600SF3TCRS**  
(Reduced Bore)

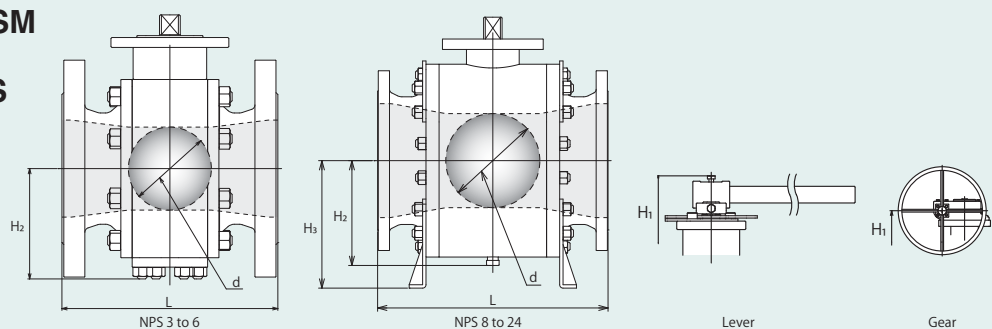

Dimensions of T60S/(G)-600UF3TCRSM, T60S/(G)-600SF3TCRS

Page 95 for Pressure-Temperature Ratings.

Nominal Size	NPS DN	3	4	6	8	10	12	14	16	18	20	24	
		80	100	150	200	250	300	350	400	450	500	600	
Valve operator		Lever						Gear					
Ball bore	in.	1.94	2.94	3.94	5.94	7.94	9.94	11.94	13.19	15.19	17.19	19.19	
	mm	49	74	100	150	201	252	303	334	385	436	487	
L	in.	14.00	17.00	22.00	26.00	31.00	33.00	35.00	39.00	43.00	47.00	55.00	
	mm	356	432	559	660	787	838	889	991	1092	1194	1397	
H <sub>1</sub>	in.	7.17	9.29	10.35	11.06	13.43	15.31	17.76	19.29	21.30	23.78	25.79	
	mm	182	236	263	281	341	389	451	490	541	604	655	
H <sub>2</sub>	in.	3.86	4.72	5.91	7.68	9.69	-	-	-	-	-	-	
	mm	98	120	150	195	246	-	-	-	-	-	-	
H <sub>3</sub>	in.	-	-	-	-	-	15.28	16.77	17.80	19.53	21.54	23.07	
	mm	-	-	-	-	-	388	426	452	496	547	586	

## Class 150 Metal Seated Stainless Steel/Carbon Steel Ball Valves (Trim 6H)

### 3-Piece body, Side entry design

**T60M/(G-)150UF3TC6HM**  
(Full Bore)

**T60M/(G-)150SF3TC6H**  
(Full Bore)

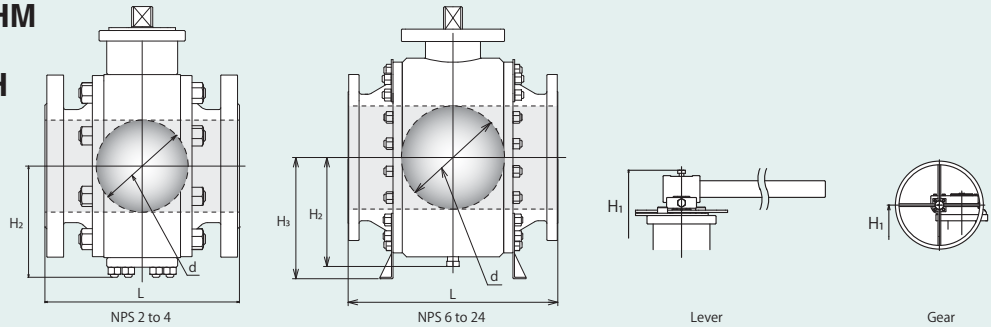

Dimensions of T60M/(G-)150UF3TC6HM, T60M/(G-)150SF3TC6H

Page 95 for Pressure-Temperature Ratings.

Nominal Size	NPS DN	2 50	3 80	4 100	6 150	8 200	10 250	12 300	14 350	16 400	18 450	20 500	24 600
Valve operator		Lever						Gear					
Ball bore	in.	1.94	2.94	3.94	5.94	7.94	9.94	11.94	13.19	15.19	17.19	19.19	23.19
	mm	49	74	100	150	201	252	303	334	385	436	487	589
L	in.	7.00	8.00	9.00	15.50	18.00	21.00	24.00	27.00	30.00	34.00	36.00	42.00
	mm	178	203	229	394	457	533	610	686	762	864	914	1067
H <sub>1</sub>	in.	7.44	7.28	9.21	11.14	13.74	15.67	18.23	19.02	22.91	24.09	28.5	31.77
	mm	182	188	234	283	349	398	463	483	582	612	724	807
H <sub>2</sub>	in.	3.94	4.84	5.94	7.52	9.33	11.18	-	-	-	-	-	-
	mm	100	123	151	191	237	284	-	-	-	-	-	-
H <sub>3</sub>	in.	-	-	-	-	-	-	16.89	17.52	19.61	20.75	24.37	27.44
	mm	-	-	-	-	-	-	427	445	499	526	619	698

## Class 150 Metal Seated Stainless Steel/Carbon Steel Ball Valves (Trim 6H)

### 3-Piece body, Side entry design

**T60M/(G-)150UF3TCR6HM**  
(Reduced Bore)

**T60M/(G-)150SF3TCR6H**  
(Reduced Bore)

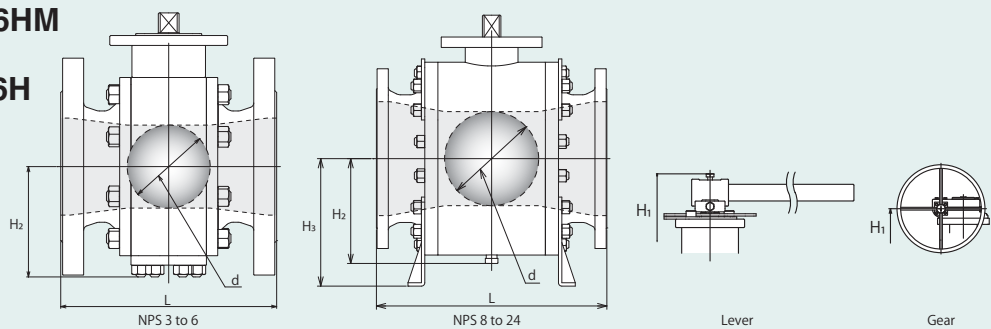

Dimensions of T60M/(G-)150UF3TCR6HM, T60M/(G-)150SF3TCR6H

Page 95 for Pressure-Temperature Ratings.

Nominal Size	NPS DN	3 80	4 100	6 150	8 200	10 250	12 300	14 350	16 400	18 450	20 500	24 600	
Valve operator		Lever						Gear					
Ball bore	in.	1.94	2.94	3.94	5.94	7.94	9.94	11.94	13.19	15.19	17.19	19.19	
	mm	49	74	100	150	201	252	303	334	385	436	487	
L	in.	8.00	9.00	15.50	18.00	21.00	24.00	27.00	30.00	34.00	36.00	42.00	
	mm	203	229	394	457	533	610	686	762	864	914	1067	
H <sub>1</sub>	in.	7.24	7.28	9.21	11.14	13.74	15.67	18.23	19.02	22.91	24.09	28.5	
	mm	187	185	233	283	345	399	464	478	583	611	712	
H <sub>2</sub>	in.	3.94	4.84	5.94	7.52	9.33	11.18	-	-	-	-	-	
	mm	96	123	154	197	241	294	-	-	-	-	-	
H <sub>3</sub>	in.	-	-	-	-	-	-	16.89	17.52	19.61	20.75	24.37	
	mm	-	-	-	-	-	-	436	451	507	534	602	

## Class 300 Metal Seated Stainless Steel/Carbon Steel Ball Valves (Trim 6H)

### 3-Piece body, Side entry design

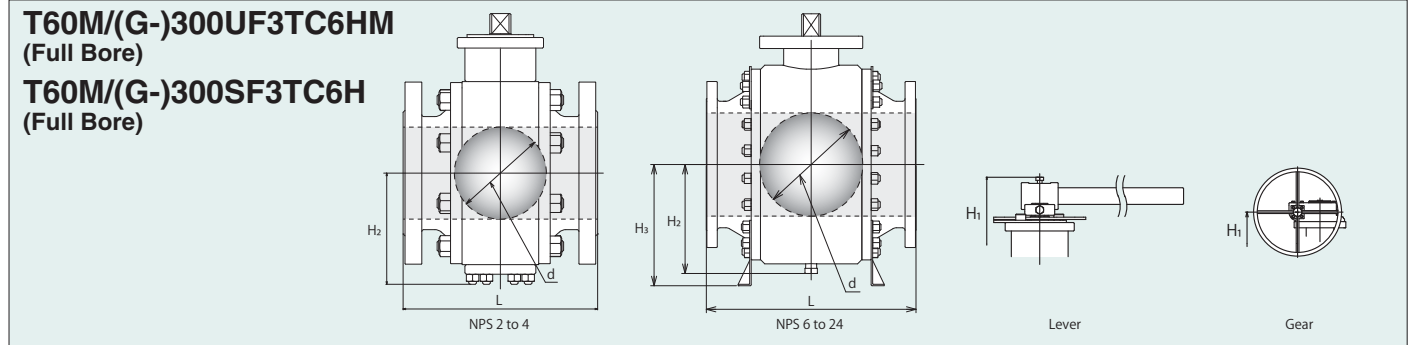

Dimensions of T60M/(G-)300UF3TC6HM, T60M/(G-)300SF3TC6H

Page 95 for Pressure-Temperature Ratings.

Nominal Size	NPS DN	2	3	4	6	8	10	12	14	16	18	20	24
		50	80	100	150	200	250	300	350	400	450	500	600
Valve operator		Lever						Gear					
Ball bore	in.	1.94	2.94	3.94	5.94	7.94	9.94	11.94	13.19	15.19	17.19	19.19	23.19
	mm	49	74	100	150	201	252	303	334	385	436	487	589
L	in.	8.50	11.13	12.00	15.88	19.75	22.38	25.50	30.00	33.00	36.00	39.00	45.00
	mm	216	283	305	403	502	568	648	762	838	914	991	1143
H <sub>1</sub>	in.	7.24	7.28	9.53	11.69	13.7	15.67	18.58	19.37	22.91	24.29	28.5	31.81
	mm	182	188	242	297	348	398	472	492	582	617	724	808
H <sub>2</sub>	in.	3.94	4.84	5.94	7.52	9.33	11.18	-	-	-	-	-	-
	mm	100	123	151	191	237	284	-	-	-	-	-	-
H <sub>3</sub>	in.	-	-	-	-	-	-	16.89	17.52	19.61	20.75	24.37	27.52
	mm	-	-	-	-	-	-	429	445	498	529	618	699

## Class 300 Metal Seated Stainless Steel/Carbon Steel Ball Valves (Trim 6H)

### 3-Piece body, Side entry design

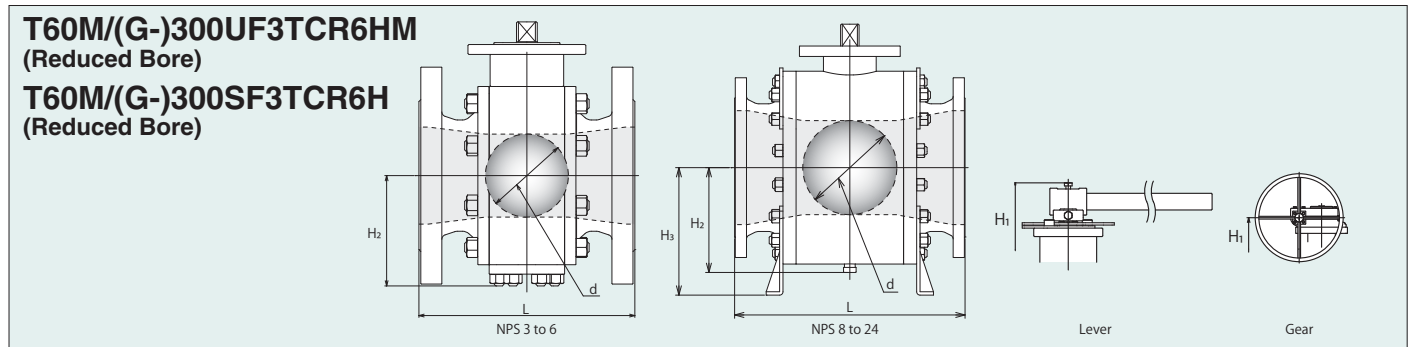

Dimensions of T60M/(G-)300UF3TCR6HM, T60M/(G-)300SF3TCR6H

Page 95 for Pressure-Temperature Ratings.

Nominal Size	NPS DN	3	4	6	8	10	12	14	16	18	20	24	
		80	100	150	200	250	300	350	400	450	500	600	
Valve operator		Lever						Gear					
Ball bore	in.	1.94	2.94	3.94	5.94	7.94	9.94	11.94	13.19	15.19	17.19	19.19	
	mm	49	74	100	150	201	252	303	334	385	436	487	
L	in.	11.13	12.00	15.88	19.75	22.38	25.50	30.00	33.00	36.00	39.00	45.00	
	mm	283	305	403	502	568	648	762	838	914	991	1143	
H <sub>1</sub>	in.	7.24	7.28	9.53	11.69	13.7	15.67	18.58	19.37	22.91	24.29	28.5	
	mm	187	188	241	297	344	399	472	487	583	618	726	
H <sub>2</sub>	in.	3.94	4.84	5.94	7.52	9.33	11.18	-	-	-	-	-	
	mm	96	123	154	197	241	294	-	-	-	-	-	
H <sub>3</sub>	in.	-	-	-	-	-	-	16.89	17.52	19.61	20.75	24.37	
	mm	-	-	-	-	-	-	436	451	507	534	602	

## Class 600 Metal Seated Stainless Steel/Carbon Steel Ball Valves (Trim 6H)

### 3-Piece body, Side entry design

**T60M/G-600UF3TC6HM**  
(Full Bore)

**T60M/G-600SF3TC6H**  
(Full Bore)

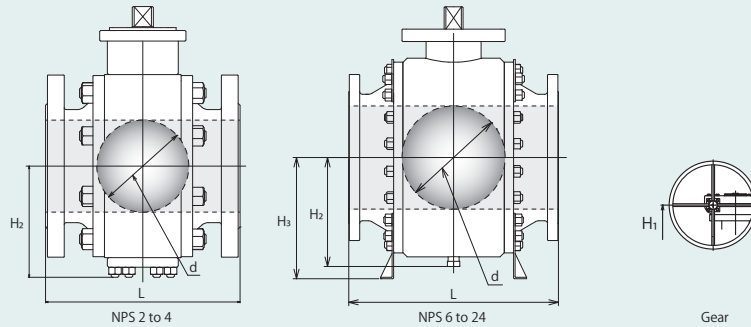

Dimensions of T60M/G-600UF3TC6HM, T60M/G-600SF3TC6H

Page 95 for Pressure-Temperature Ratings.

Nominal Size	NPS DN	2 50	3 80	4 100	6 150	8 200	10 250	12 300	14 350	16 400	18 450	20 500	24 600
Valve operator		Gear											
Ball bore	in.	1.94	2.94	3.94	5.94	7.94	9.94	11.94	13.19	15.19	17.19	19.19	23.19
	mm	49	74	100	150	201	252	303	334	385	436	487	589
L	in.	11.50	14.00	17.00	22.00	26.00	31.00	33.00	35.00	39.00	43.00	47.00	55.00
	mm	292	356	432	559	660	787	838	889	991	1092	1194	1397
H <sub>1</sub>	in.	6.50	8.7	10.35	11.65	14.33	15.83	18.39	21.5	23.66	26.97	28.54	32.2
	mm	168	221	263	296	364	402	467	546	601	685	725	818
H <sub>2</sub>	in.	4.06	5.28	6.5	7.52	9.69	-	-	-	-	-	-	-
	mm	103	134	165	191	246	-	-	-	-	-	-	-
H <sub>3</sub>	in.	-	-	-	-	-	15.12	16.81	18.11	19.61	21.81	24.53	28.39
	mm	-	-	-	-	-	384	427	460	498	554	643	721

## Class 600 Metal Seated Stainless Steel/Carbon Steel Ball Valves (Trim 6H)

### 3-Piece body, Side entry design

**T60M/G-600UF3TCR6HM**  
(Reduced Bore)

**T60M/G-600SF3TCR6H**  
(Reduced Bore)

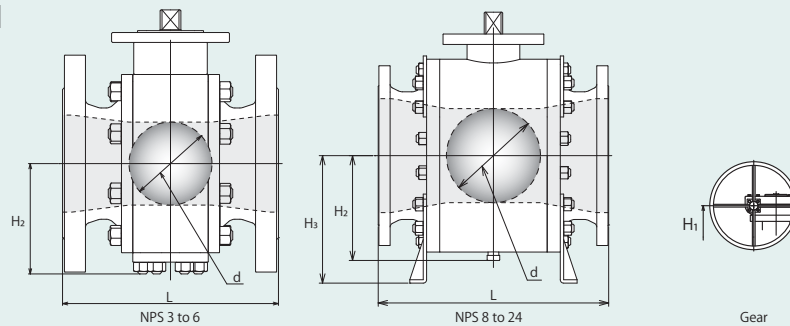

Dimensions of T60M/G-600UF3TCR6HM, T60M/G-600SF3TCR6H

Page 95 for Pressure-Temperature Ratings.

Nominal Size	NPS DN	3 80	4 100	6 150	8 200	10 250	12 300	14 350	16 400	18 450	20 500	24 600	
Valve operator		Gear											
Ball bore	in.	1.94	2.94	3.94	5.94	7.94	9.94	11.94	13.19	15.19	17.19	19.19	
	mm	49	74	100	150	201	252	303	334	385	436	487	
L	in.	14.00	17.00	22.00	26.00	31.00	33.00	35.00	39.00	43.00	47.00	55.00	
	mm	356	432	559	660	787	838	889	991	1092	1194	1397	
H <sub>1</sub>	in.	6.50	8.7	10.35	11.65	14.33	15.83	18.39	21.5	23.66	26.97	28.54	
	mm	165	220	262	296	364	403	468	547	602	685	727	
H <sub>2</sub>	in.	4.06	5.28	6.50	7.52	9.69	-	-	-	-	-	-	
	mm	103	133	165	197	252	-	-	-	-	-	-	
H <sub>3</sub>	in.	-	-	-	-	-	15.12	16.81	18.11	19.61	21.81	24.53	
	mm	-	-	-	-	-	394	436	469	507	563	602	

## Construction

### ■ Class 150/300/600 Soft Seated 3-Piece Body Trunnion Ball Valves up to NPS 4

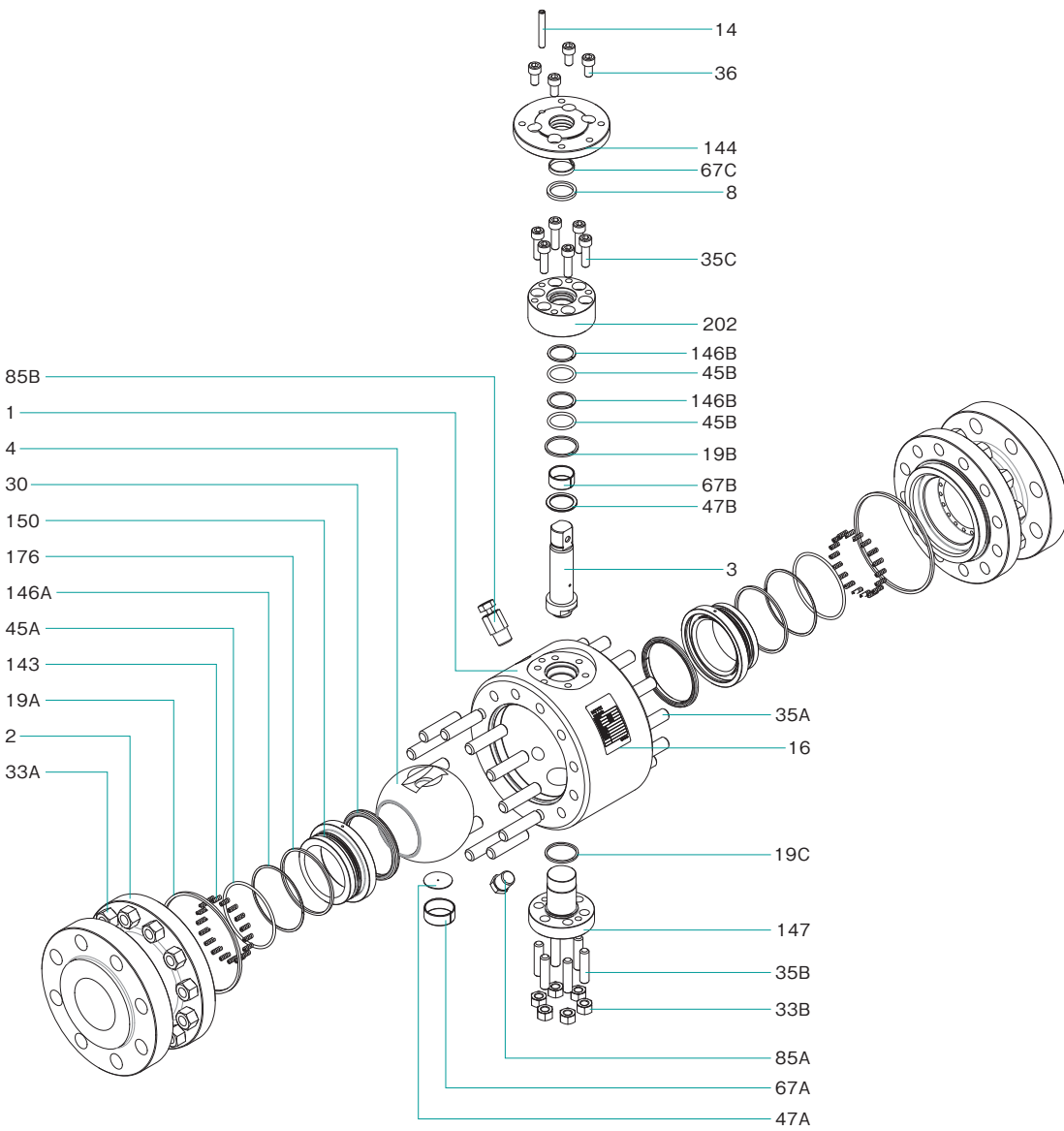

No	Name of Parts
1	Body
2	Cap
3	Stem
4	Ball
8	Gland packing
14	Set pin
16	Name plate
19A	Gasket
19B	Gasket
19C	Gasket
30	Ball seat
33A	Cap nut
33B	Cover nut
35A	Cap bolt
35B	Cover bolt
35C	Bonnet bolt
36	Gland bolt
45A	O-ring
45B	O-ring
47A	Thrust washer
47B	Thrust washer
67A	Curl bearing
67B	Stem bearing
67C	Stem bearing
85A	Plug
85B	Vent valve
143	Seat spring
144	Gland plate
146A	Back-up ring
146B	Back-up ring
147	End plate
150	Seat retainer
176	Retainer packing
202	Bonnet

## Construction

### ■ Class 150/300/600 Soft Seated 3-Piece Body Trunnion Ball Valves NPS 6 and larger

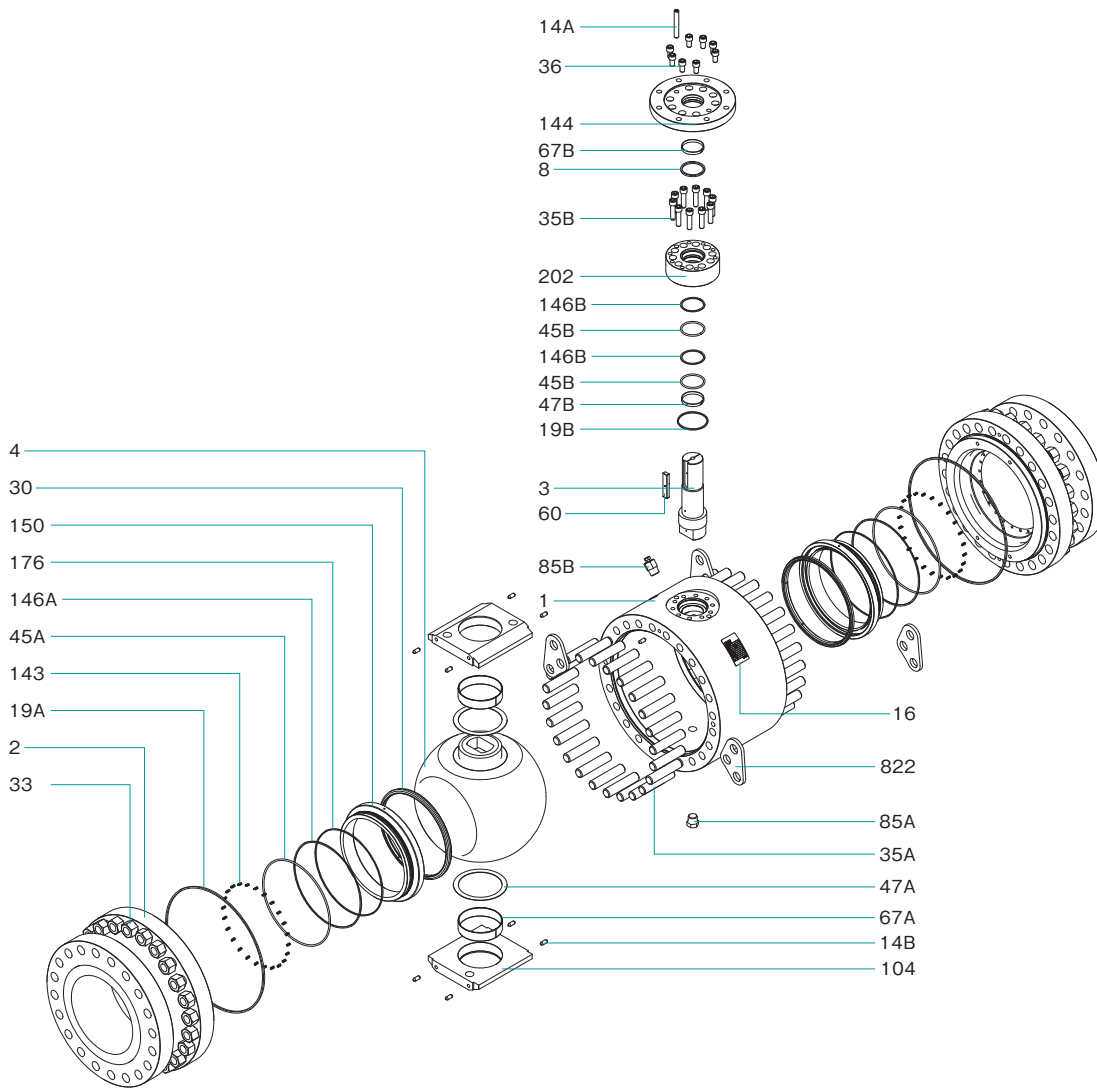

No	Name of Parts
1	Body
2	Cap
3	Stem
4	Ball
8	Gland packing
14A	Set pin
14B	Set pin
16	Name plate
19A	Gasket
19B	Gasket
30	Ball seat
33	Cap nut
35A	Cap bolt
35B	Bonnet bolt
36	Gland bolt
45A	O-ring
45B	O-ring
47A	Thrust washer
47B	Thrust washer
60	Key
67A	Curf bearing
67B	Stem bearing
85A	Plug
85B	Vent valve
104	Trunnion plate
143	Seat spring
144	Gland plate
146A	Back-up ring
146B	Back-up ring
150	Seat retainer
176	Retainer packing
202	Bonnet
822	Lifting lug

## Construction

### ■ Class 150/300/600 Metal Seated 3-Piece Body Trunnion Ball Valves up to NPS 4

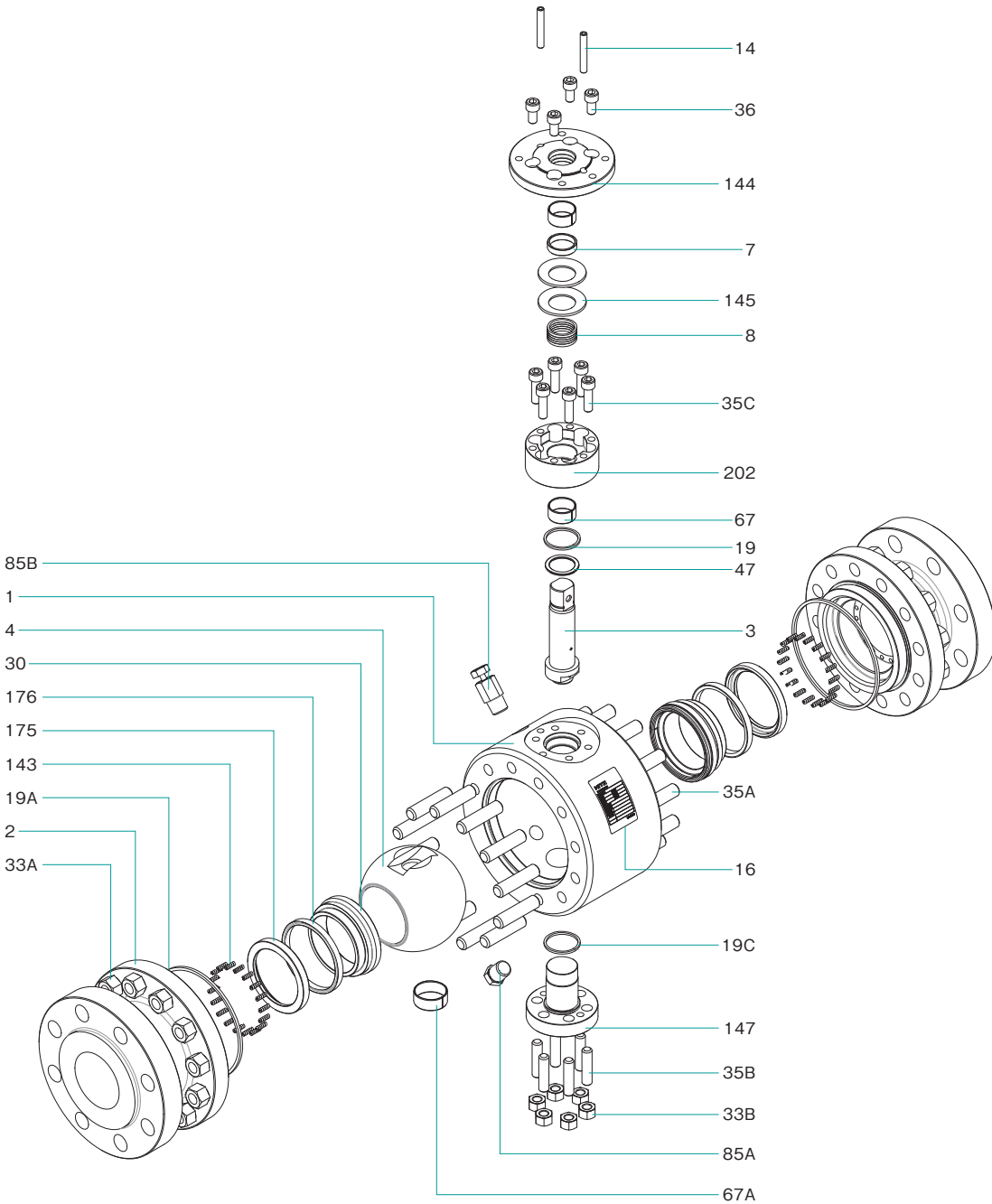

No	Name of Parts
1	Body
2	Cap
3	Stem
4	Ball
7	Gland
8	Gland packing
14	Set pin
16	Name plate
19A	Gasket
19B	Gasket
19C	Gasket
30	Ball seat
33A	Cap nut
33B	Cover nut
35A	Cap bolt
35B	Cover bolt
35C	Bonnet bolt
36	Gland bolt
47	Thrust washer
67A	Curli bearing
67B	Stem bearing
85A	Plug
85B	Vent valve
143	Seat spring
144	Gland plate
145	Coned disc spring
147	End plate
175	Retainer gland
176	Seat packing
202	Bonnet



## Construction

### ■ Class 150/300/600 Metal Seated 3-Piece Body Trunnion Ball Valves NPS 6 and larger

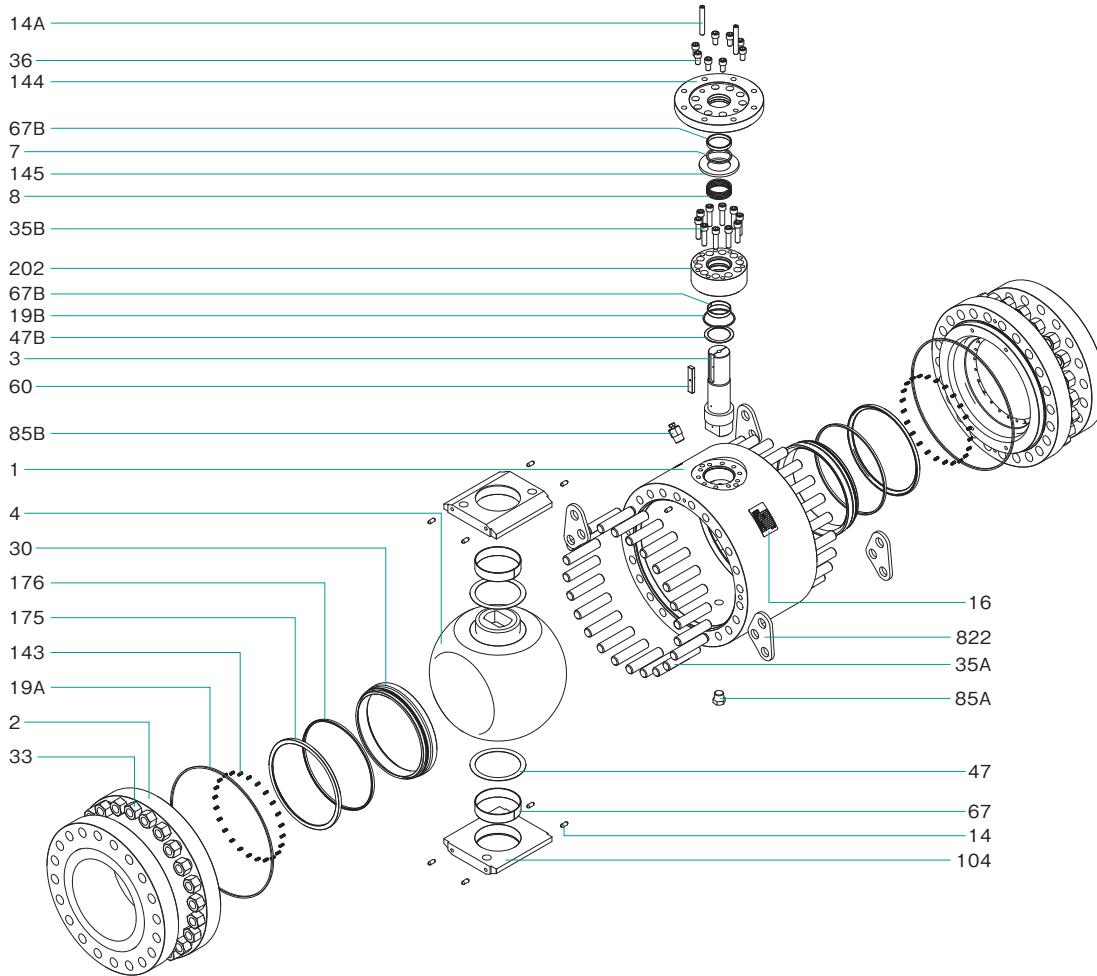

No	Name of Parts
1	Body
2	Cap
3	Stem
4	Ball
7	Gland
8	Gland packing
14A	Set pin
14B	Set pin
16	Name plate
19A	Gasket
19B	Gasket
30	Ball seat
33	Cap nut
35A	Cap bolt
35B	Bonnet bolt
36	Gland bolt
47A	Thrust washer
47B	Thrust washer
60	Key
67A	Cur bearing
67B	Stem bearing
85A	Plug
85B	Vent valve
104	Trunnion plate
143	Seat spring
144	Gland plate
145	Coned disc spring
175	Retainer gland
176	Retainer packing
202	Bonnet
822	Lifting lug

# Floating Ball Valves (Threaded or Solder Joint)

## Type 600 Carbon Steel Ball Valves

### Reduced bore, Uni-body design, Threaded ends

#### Features

- Blowout-proof stem
- Choice of threaded ends:
  - Rc threads to JIS B0203 (BS 21) (Fig. SCKT)
  - NPT threads to ASME B1.20.1 (Fig. AKSCKT)

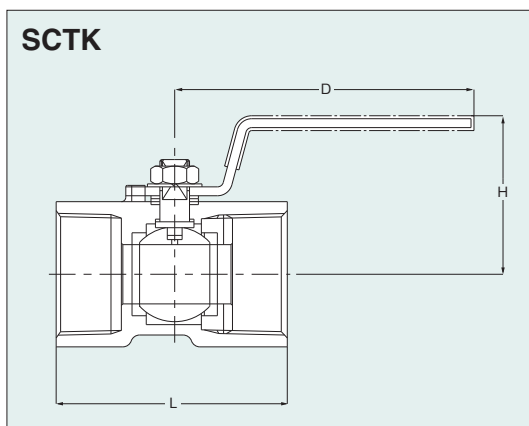

#### Dimensions of SCKT

Unit: mm

Nominal Size	NPS	1/4	3/8	1/2	3/4	1	1 1/4	1 1/2	2
	DN	8	10	15	20	25	32	40	50
Ball bore		4.5	6.8	9.2	12.5	16	20	24.5	32
L		39	44	56.5	59	71	78	83	100
H		31	36	39	43	48	53	62	70
D		60	70	85	85	100	100	125	125

Page 102 for Pressure-Temperature Ratings.

#### Materials

Parts	Materials
Body	A216 Gr. WCB
Ball	A276 Type 316 or 304*1
Stem	A276 Type 316 or 304*2
Ball seat	G/F PTFE
Gland packing	G/F PTFE
Handle	Plastic covered S.S.

- \* 1 304 for NPS 1/2 and larger
- \* 2 304 for NPS 3/4 and larger

End to end dimensions: KITZ standard

#### Valve operator

Lever operation  
T-type handle as option (NPS 3/4 and larger)

## Type 1500/2000 Carbon Steel Ball Valves

### Reduced bore, Split body design, Threaded ends

#### Features

- Blowout-proof stem
- API 607 fire-safe type as option
- NPT threaded ends to ASME B1.20.1

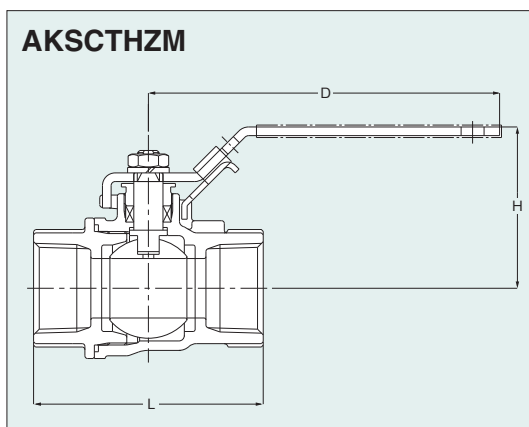

#### Dimensions of AKSCTH2M

Unit: mm

Nominal Size	NPS	1/4	3/8	1/2	3/4	1	1 1/4	1 1/2	2
	DN	8	10	15	20	25	32	40	50
Ball bore		9.5	9.5	10	15	20	25	32	40
L		53	53	62	72	85	94	107	120
H		50.5	50.5	58.5	64	63.5	67.5	83	89
D		100	100	115	115	135	135	155	190

Page 103 for Pressure-Temperature Ratings.

#### Materials

Parts	Materials
Body	A216 Gr. WCB
Body cap	A216 Gr. WCB
Ball	A276 Type 316
Stem	A276 Type 316
Seat	HYPATITE® PTFE
Gland packing	PTFE*
Gasket	PTFE*
Handle	Plastic covered C.S.

- \* API 607 fire-safe flexible graphite is optionally available.

End to end dimensions: KITZ standard

#### Valve operator

Lever operation with latch lock  
Oval handle as option

## Type 1500/2000 Carbon Steel Ball Valves

### Reduced bore, Welded body design, Threaded ends

#### Features

- Blowout-proof stem
- API 607 fire-safe type as option
- NPT threaded ends to ASME B1.20.1

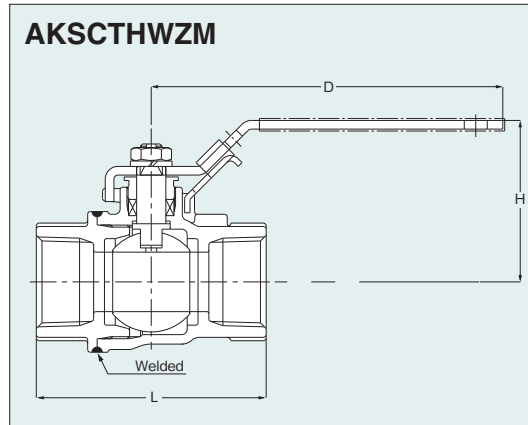

#### Dimensions of AKSCTHWZM

Unit: mm

Nominal Size	NPS	1/4	3/8	1/2	3/4	1	1 1/4	1 1/2	2
	DN	8	10	15	20	25	32	40	50
Ball bore		9.5	9.5	10	15	20	25	32	40
L		53	53	62	72	85	94	107	120
H		50.5	50.5	58.5	64	63.5	67.5	83	89
D		100	100	115	115	135	135	155	190

#### Materials

Parts	Materials
Body	A216 Gr. WCB
Body cap	A216 Gr. WCB
Ball	A276 Type 316
Stem	A276 Type 316
Seat	HYPATITE® PTFE
Gland packing	PTFE*
Handle	Plastic covered C.S.

\* API 607 fire-safe flexible graphite is optionally available.

End to end dimensions: KITZ standard

#### Valve operator

Lever operation with latch lock  
Oval handle as option

## Class 800 and Type 3000 Carbon Steel Ball Valves

### Reduced bore, Welded body design, Threaded ends

#### Features

- Antistatic device
- Blowout-proof stem
- Fire test certification (800SCTK only)★
- Choice of threaded ends:
  - Rc threads to JIS B0203 (BS 21) (Fig. 800/3000SCTK)
  - NPT threads to ASME B1.20.1 (Fig. AK800/3000SCTK)

#### Note

1. Class 800 ball valves are designed to BS 5351.
2. Type 3000 ball valves are designed to KITZ standard for servicing water, oil and gaseous fluid under the maximum working pressure of 3000 psi.

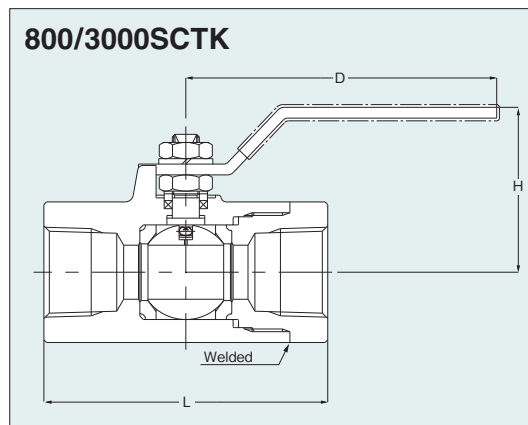

#### Dimensions of 800SCTK, 3000SCTK

Unit: mm

Nominal Size	NPS	1/4	3/8	1/2	3/4	1	1 1/4	1 1/2	2
	DN	8	10	15	20	25	32	40	50
Ball bore		10	10	10	15	20	25	32	38
L		88	88	88	90	105	117	130	150
H	Class 800	46	46	46	54	57	64	69	80
	Type 3000	44	44	44	54	57	64	69	80
D	Class 800	100	100	100	115	115	135	135	150
	Type 3000	100	100	100	115	115	160	160	230

#### Materials

Parts	Materials
Body	A105
Body cap	A105
Stem	A276 Type 316 (Class 800) SUS 329J1 (Type 3000)
Ball	A276 Type 316
Gland packing	PTFE
Ball seat	PTFE (Class 800) PCTFE* (Type 3000)

\* Polychloro-Trifluoro-Ethylene.

#### Valve operator

Lever operation

#### Option

★ Flexible graphite packing.

Page 103 for Pressure-Temperature Ratings.

Page 103 for Pressure-Temperature Ratings.

## Class 800 and Type 3000 Carbon Steel Ball Valves

### Reduced bore, Split body design, Socket welding ends

#### Features

- Antistatic device
- Blowout-proof stem
- Socket welding ends to ASME B16.11

#### Note

1. Class 800 ball valves are designed to BS 5351.
2. Type 3000 ball valves are designed to KITZ standard for servicing water, oil and gaseous fluid under the maximum working pressure of 3000 psi.

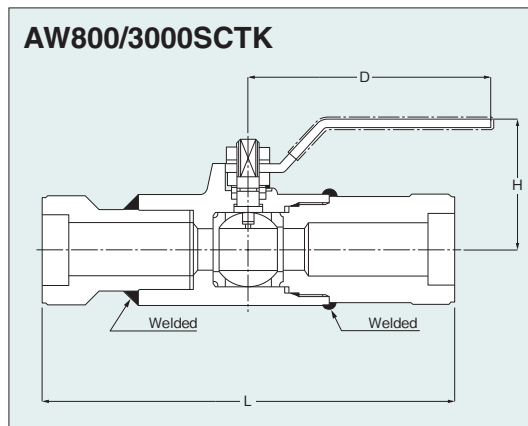

#### Dimensions of AW800SCTK, AW3000SCTK

Unit: mm

Nominal Size	NPS	1/4	3/8	1/2	3/4	1	1 1/4	1 1/2	2
	DN	8	10	15	20	25	32	40	50
Ball bore		10	10	10	15	20	25	32	38
L		170	170	170	176	196	210	226	262
H		44	44	44	54	57	65	70	81
D	Class 800	100	100	100	115	115	135	135	150
	Type 3000	100	100	100	115	115	160	160	230

Page 102 for Pressure-Temperature Ratings.

#### Materials

Parts	Materials
Body	A105
Body cap	A105
Stem	A276 Type 316 (Class 800) SUS 329J1 (Type 3000)
Ball	A276 Type 316
Gland packing	Flexible graphite
Ball seat	PTFE (Class 800) PCTFE* (Type 3000)

\* Polychloro-Trifluoro-Ethylene.

End to end dimensions: KITZ standard

#### Valve operator

Lever operation

## Type 600 Stainless Steel Ball Valves

### Reduced bore, Uni-body design, Threaded ends

#### Features

- Blowout-proof stem
- Choice of threaded ends:
  - Rc threads to JIS B0203 (BS 21) (Fig. UTKM)
  - NPT threads to ASME B1.20.1 (Fig. AKUTKM)

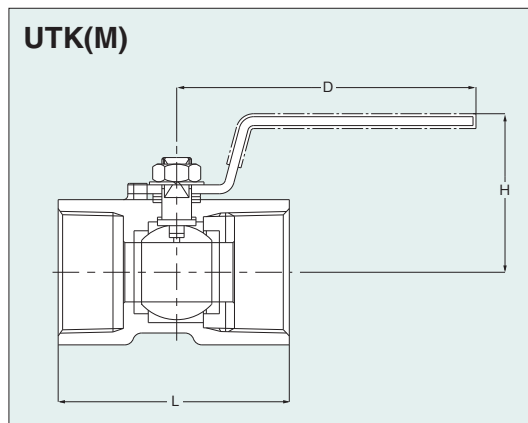

#### Dimensions of UTK(M)

Unit: mm

Nominal Size	NPS	1/4	3/8	1/2	3/4	1	1 1/4	1 1/2	2
	DN	8	10	15	20	25	32	40	50
Ball bore		4.5	6.8	9.2	12.5	16	20	24.5	32
L		39	44	56.5	59	71	78	83	100
H		31	36	41	44	48	54	65	72
D		60	70	85	85	100	100	125	125

Page 102 for Pressure-Temperature Ratings.

#### Materials

Parts	Materials
Body	A351 Gr.CF8 (A351 Gr.CF8M)
Ball	A276 Type 304 or A351 Gr.CF8 (A276 Type 316* or A351 Gr.CF8M*)
Stem	A276 Type 316 or 304
Seat	G/F PTFE
Gland packing	G/F PTFE
Handle	Plastic covered S.S.

End to end dimensions: KITZ standard

\* CF8M/316 are available for (M).

#### Valve operator

Lever operation

T-type handle as option

## Type 800 Stainless Steel Ball Valves

### Reduced bore, Split body design, Threaded ends

#### Features

- Blowout-proof stem
- Choice of threaded ends:
  - Rc threads to JIS B0203 (BS 21) (Fig. UTHM)
  - NPT threads to ASME B1.20.1 (Fig. AKUTHM)

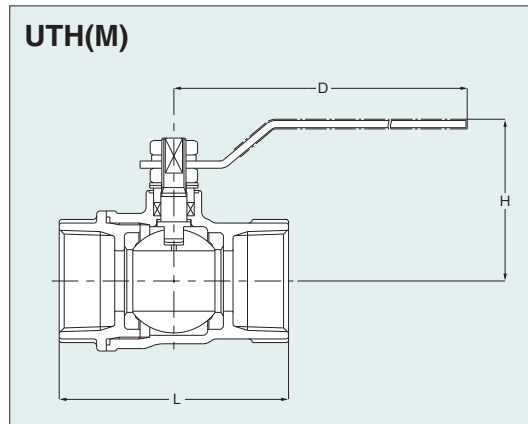

#### Dimensions of UTH(M)

Nominal Size	NPS	1/2	3/4	1	1 1/4	1 1/2	2
	DN	15	20	25	32	40	50
Ball bore		10	15	20	25	32	40
L		60	70	80	95	108	124
H		49	54	64	68	79	85
D		100	100	130	130	150	150

Unit: mm

#### Materials

Parts	Materials
Body	A351 Gr.CF8 (A351 Gr.CF8M)
Body cap	A351 Gr.CF8 (A351 Gr.CF8M)
Ball	A276 Type 304 or A351 Gr.CF8 (A276 Type 316* or A351 Gr.CF8M*)
Stem	A276 Type 316 or 304
Seat	PTFE
Gland packing	PTFE
Handle	Plastic covered S.S.

End to end dimensions: KITZ standard  
\* CF8M/316 are available for (M).

#### Valve operator Lever operation

## Type 1000 Stainless Steel Ball Valves

### Full port, Split body design, Threaded ends

#### Features

- Blowout-proof stem
- Choice of threaded ends:
  - Rc threads to JIS B0203 (BS 21) (Fig. UTFM)
  - NPT threads to ASME B1.20.1 (Fig. AKUTFM)

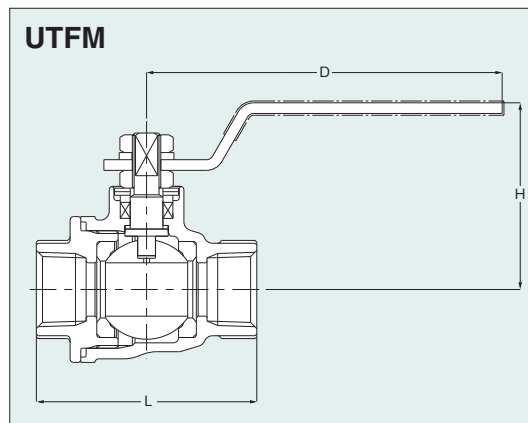

#### Dimensions of UTFM

Nominal Size	NPS	1/2	3/4	1	1 1/4	1 1/2	2
	DN	15	20	25	32	40	50
Ball bore		15	20	25	32	40	50
L		62	73	85	98	108	124
H		53	63	67	75	81	102
D		100	130	130	150	150	200

Unit: mm

#### Materials

Parts	Materials
Body	A351 Gr.CF8M
Body cap	A351 Gr.CF8M
Ball	A276 Type 316 or A351 Gr.CF8M
Stem	A276 Type 316
Seat	HYPATITE® PTFE
Gland packing	PTFE
Gasket	PTFE
Handle	Plastic covered S.S.

End to end dimensions: KITZ standard

#### Valve operator Lever operation

Page 102 for Pressure-Temperature Ratings.

Page 102 for Pressure-Temperature Ratings.

## Type 1500/2000 Stainless Steel Ball Valves

### Reduced bore, Split body design, Threaded ends

#### Features

- Blowout-proof stem
- API 607 fire-safe type as option
- NPT threads to ASME B1.20.1

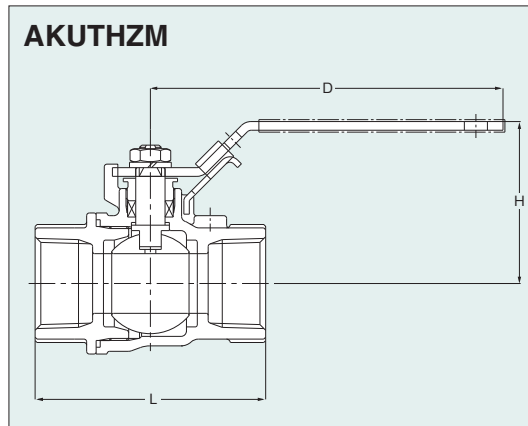

#### Dimensions of AKUTHZM

Unit: mm

Nominal Size	NPS	1/4	3/8	1/2	3/4	1	1 1/4	1 1/2	2
	DN	8	10	15	20	25	32	40	50
Ball bore		9.5	9.5	10	15	20	25	32	40
L		53	53	62	72	85	94	107	120
H		50.5	50.5	58.5	64	63.5	67.5	83	89
D		100	100	115	115	135	135	155	190

Page 103 for Pressure-Temperature Ratings.

#### Materials

Parts	Materials
Body	A351 Gr.CF8M
Body cap	A351 Gr.CF8M
Ball	A276 Type 316
Stem	A276 Type 316
Seat	HYPATITE® PTFE
Gland packing	PTFE
Gasket	PTFE
Handle	Plastic covered S.S.

\* API 607 fire-safe flexible graphite is optionally available.

End to end dimensions: KITZ standard

#### Valve operator

Lever operation with latch lock  
Oval handle as option

## Type 1500/2000 Stainless Steel Ball Valves

### Reduced bore, Welded body design, Threaded ends

#### Features

- Blowout-proof stem
- API 607 fire-safe type as option
- NPT threads to ASME B1.20.1

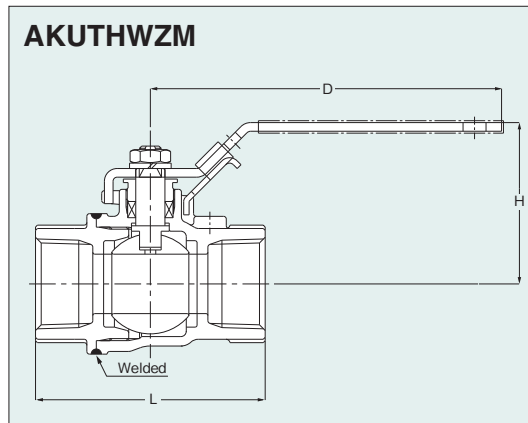

#### Dimensions of AKUTHWZM

Unit: mm

Nominal Size	NPS	1/4	3/8	1/2	3/4	1	1 1/4	1 1/2	2
	DN	8	10	15	20	25	32	40	50
Ball bore		9.5	9.5	10	15	20	25	32	40
L		53	53	62	72	85	94	107	120
H		50.5	50.5	58.5	64	63.5	67.5	83	89
D		100	100	115	115	135	135	155	190

Page 103 for Pressure-Temperature Ratings.

#### Materials

Parts	Materials
Body	A351 Gr.CF8M
Body cap	A351 Gr.CF8M
Ball	A276 Type 316
Stem	A276 Type 316
Seat	HYPATITE® PTFE
Gland packing	PTFE
Handle	Plastic covered S.S.

\* API 607 fire-safe flexible graphite is optionally available.

End to end dimensions: KITZ standard

#### Valve operator

Lever operation with latch lock  
Oval handle as option

## Type 1000 Stainless Steel Ball Valves

### Full bore, 3-piece body design, Threaded or socket welding ends

#### Features

- Blowout-proof stem
- Swing-away body for maintenance ease
- Choice of threaded ends:
  - Rc threads to JIS B0203 (BS 21) (Fig. U3TZFM)
  - NPT threads to ASME B1.20.1 (Fig. AKU3TZFM)
  - Socket welding ends to JIS B2316 (BS 5351)/ ASME B16.11 (Fig. SWU3TZFM)
  - Socket welding ends to ASME B16.11 (Fig. AWU3TZFM)

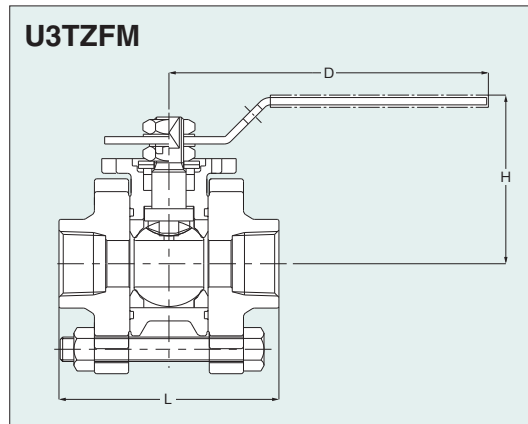

#### Dimensions of U3TZFM

Nominal Size	NPS	1/4	3/8	1/2	3/4	1	1 1/4	1 1/2
	DN	8	10	15	20	25	32	40
Ball bore		10	10	14	19	24	30	38
L		63	63	71	90	103	110	127
H		48	48	60	69	82	88	104
D		120	120	130	130	150	150	180

Unit: mm

#### Materials

Parts	Materials
Body	A351 Gr.CF8M
Body cap	A351 Gr.CF8M
Ball	A276 Type 316 or A351 Gr.CF8M
Stem	A276 Type 316
Seat	HYPATITE® PTFE
Gland packing	PTFE
Gasket	PTFE
Handle	Plastic covered S.S.

End to end dimensions: KITZ standard

#### Valve operator

Lever operation  
Oval handle as option

#### Note

· Use U3TZM for NPS 2.

## Type 1000 Stainless Steel Ball Valves

### Reduced bore, 3-piece body design, Threaded or socket welding ends

#### Features

- Blowout-proof stem
- Swing-away body for maintenance ease
- Choice of threaded ends:
  - Rc threads to JIS B0203 (BS 21) (Fig. U3TZM)
  - NPT threads to ASME B1.20.1 (Fig. AKU3TZM)
  - Socket welding ends to JIS B2316 (BS 5351)/ ASME B16.11 (Fig. SWU3TZM)
  - Socket welding ends to ASME B16.11 (Fig. AWU3TZM)

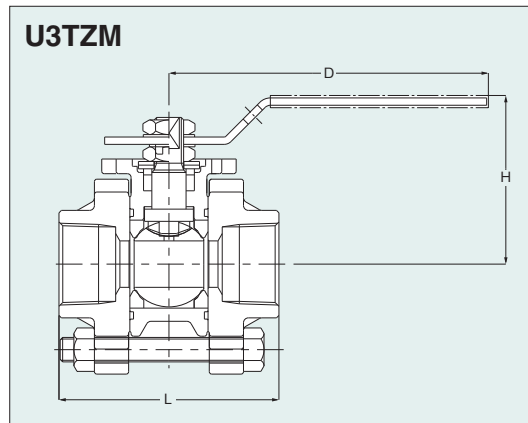

#### Dimensions of U3TZM

Nominal Size	NPS	1/2	3/4	1	1 1/4	1 1/2	2
	DN	15	20	25	32	40	50
Ball bore		10	14	19	24	30	38
L		63	71	90	103	110	127
H		48	60	69	83	88	104
D		120	130	130	150	150	180

Unit: mm

#### Materials

Parts	Materials
Body	A351 Gr.CF8M
Body cap	A351 Gr.CF8M
Ball	A276 Type 316 or A351 Gr.CF8M
Stem	A276 Type 316
Seat	HYPATITE® PTFE
Gland packing	PTFE
Gasket	PTFE
Handle	Plastic covered S.S.

End to end dimensions: KITZ standard

#### Valve operator

Lever operation  
Oval handle as option

#### Note

· Use U3TZFM for NPS 1/4 and 3/8.

Page 102 for Pressure-Temperature Ratings.

Page 102 for Pressure-Temperature Ratings.



## Type 800 Stainless Steel 3-way Ball Valves

### Reduced bore, 4-seated, Split body, Threaded ends

- L-port and T-port
- Rc threads to JIS B0203 (BS 21)

**UTH4LM (L-port)**  
**UTH4TM (T-port)**

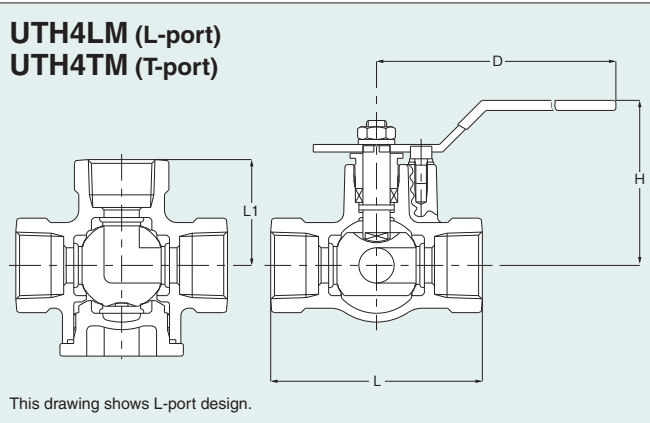

#### Dimensions of UTH4LM, UTH4TM

Unit: mm

Nominal Size	NPS	1/2	3/4	1	1 1/4	1 1/2	2
	DN	15	20	25	32	40	50
Ball bore		10	14	19	25	32	38
L		69	84	96	114	132	150
L1		34.5	42	48	57	66	75
H		63	65	75.5	79.5	95.5	101
D		130	130	150	150	230	230

Page 102 for Pressure-Temperature Ratings.

#### Materials

Parts	Materials
Body	SCS14A
Body cap	SCS14A
Ball	SUS316 or SCS14A
Stem	SUS316 Cr. plated
Seat	HYPATITE® PTFE
Gland packing	PTFE
Gasket	PTFE
Handle	Plastic covered S.S.

End to end dimensions: KITZ standard

Page 106 for Allowable Port Orientation.

#### Valve operator

Lever operation

## 10K Stainless Steel Ball Valves

### Full bore, Split body, Side entry design, Threaded ends

- Choice of threaded ends:
  - Rc threads to JIS B0203 (BS 21) (Fig. 10UTM)

**10UT(M)**

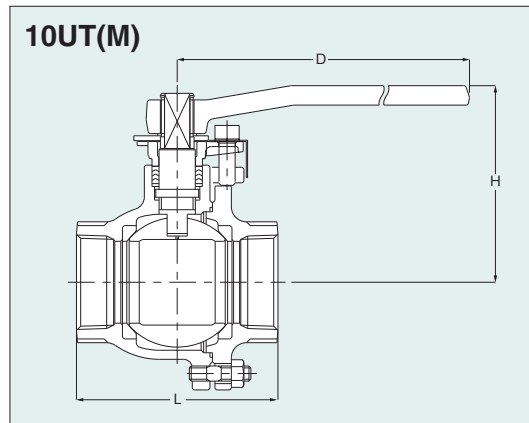

#### Dimensions of 10UT(M)

Unit: mm

Nominal Size	NPS	3/8	1/2	3/4	1	1 1/4	1 1/2	2	2 1/2	3
	DN	10	15	20	25	32	40	50	65	80
Ball bore		10	15	20	25	32	40	50	65	80
L		62	65	80	90	110	120	140	160	182
H		71	102	105	124	130	115	120	155	165
D		130	130	130	160	160	230	230	400	400

Refer to "Product Range" on Page 7.

Page 103 for Pressure-Temperature Ratings.

#### Materials

Parts	Materials
Body	SCS13A (SCS14A*)
Body cap	SCS13A (SCS14A*)
Ball	SUS316 or SCS14A
Stem	SUS304 (SUS316*)
Seat	PTFE
Gland packing	PTFE
Gasket	PTFE
Handle	Plastic covered S.S.

End to end dimensions: KITZ standard  
Wall thickness: ASME B16.34 Class 150  
\*SCS14A/SUS316 are available for (M).

#### Valve operator

Lever operation

## 20K Ball Valves (Reduced Bore)

### 20ST 20STL (Gas service)

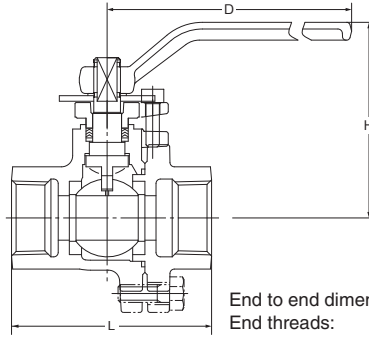

#### Maximum Service Pressure

Code	Temperature	Pressure
20ST	110°C W.O.G.	2.8 MPa
	140°C W.O.G.	2.0 MPa
20STL	80°C gas.	2.4 MPa

● Use for lubricating or hydraulic oil is acceptable.

#### Materials

Parts	JIS Material
Body	FCD-S
Body cap	FCD-S
Stem	SUS 403
Ball	SUS 304/SCS 13A
Gland	FCD-S
Gland packing	PTFE
Gasket	PTFE
Ball seat	HYPATITE® PTFE
O ring*	NBR
Gland bolt	Alloy steel
Cap bolt	Carbon steel
Handle	FCD 400-15
Name plate*	SUS 304

\*for 20STL only

End to end dimensions: KITZ Std.  
End threads: JIS B 0203

#### Dimensions of 20ST, 20STL

Unit: mm

Nominal Size	NPS	1/2	3/4	1	1 1/4	1 1/2	2
	DN	15	20	25	32	40	50
L		75	80	90	105	115	130
H		106	106	107	129	133	114
D		130	130	130	160	160	230

## Type 400 Ball Valves (Reduced Bore)

### STZ

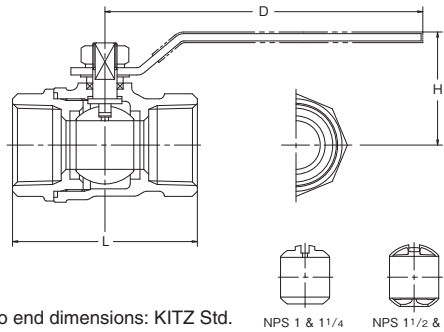

End to end dimensions: KITZ Std.  
End threads: JIS B 0203

NPS 1 & 1/4 NPS 1 1/2 & 2

W.O.G. at Room temp ..... 2.75 MPa  
Saturated steam ..... 0.98 MPa

● Use for lubricating or hydraulic oil is acceptable.

#### Materials

Parts	JIS Material
Body	FCD-S
Cap	FCD-S
Ball	C3771BE*1
Stem	C3531*1
Gland packing	PTFE
Ball seat	G/F PTFE
Gland	C3604BD*2
Gasket	PTFE
Handle nut	SS 400*3
Handle	SUS 430*4

\*1 Ni + Cr electroplated

\*2 Zinc electroplated

\*3 Zinc dichromate electroplated

\*4 Plastic covering

#### Dimensions of STZ

Unit: mm

Nominal Size	NPS	1/2	3/8	1/2	3/4	1	1 1/4	1 1/2	2
	DN	8	10	15	20	25	32	40	50
L		46	51	57	65	76	86	95	115
H		38	38	42	49	52	57	63	68
D		80	80	100	130	130	130	130	150

## 10K Iron Threaded Ball Valves (Full Bore)

120°C non-shock water 1.4 MPa, 120°C W.O.G. 1.0 MPa  
Saturated steam 0.7 MPa

### 10FCT



Blowout-proof stem

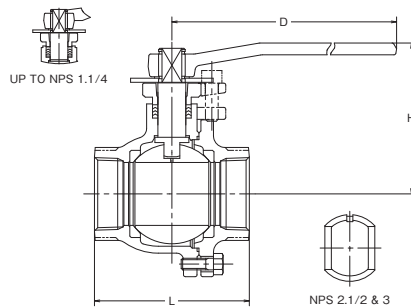

UP TO NPS 1.1/4

NPS 2 1/2 & 3

#### Materials

Parts	Material	JIS Spec.
Body	Cast iron	FC200
Body cap	Cast iron	FC200
Stem	Stainless steel	SUS403
Ball	Stainless steel	SCS13A or SUS304 or SUS304TP
Grand packing		PTFE
Gasket		PTFE
Ball Seat		PTFE
Cap bolt	Carbon steel	SS400
Handle	Ductile iron	FCD400

#### Design Specifications

Items	
Shell wall thickness and general valve design	KITZ standard
Face to face dimensions End to end dimensions	KITZ standard
End connection	JIS B0203

#### Dimensions of 10FCT

Unit: mm

Nominal Size	NPS	3/8	1/2	1/2	1	1 1/4	1 1/2	2	2 1/2	3
	DN	10	15	20	25	32	40	50	65	80
L		72	80	85	95	120	120	140	160	182
H		71	102	105	125	130	115	120	155	165
D		130	130	130	160	160	230	230	400	400

## Type 600 Brass Ball Valves (Full Bore)

W.O.G. non-shock 4.12 MPa (600 psi), Saturated steam pressure 1.03 MPa (150 psi)

Screwed body cap, Blowout-proof stem,  
Threaded ends to ASME B1.20.1

### AKTAF

- Threaded end to ASME B1.20.1

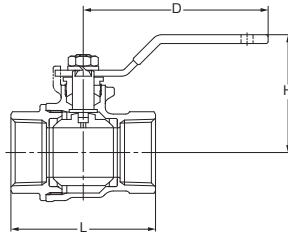

### Materials

Parts	Material
Body	Forged Brass
Body cap	Forged Brass
Stem	Dezincification resistant brass
Ball	Brass: SnNi plated (NPS 1/4 to 1) TEA plated (NPS 1 1/4 to 2)
Ball seat	PTFE
Gland packing	PTFE

### Dimensions of AKTAF

Nominal Size	NPS DN	1/4	3/8	1/2	3/4	1	1 1/4	1 1/2	2
		8	10	15	20	25	32	40	50
L		41	42	53	60	72	82	92	105
H		39	39	42	51	59	64	73	80
D		82	82	82	100	130	130	150	150

Unit: mm



## Type 600 Brass Ball Valves (Full Bore)

W.O.G. non-shock 4.12 MPa (600 psi), Saturated steam pressure 1.03 MPa (150 psi)

Screwed body cap, Blowout-proof stem,  
Solder joint ends to ASME B16.18

### CTAF

- Solder joint end to ASME B16.18

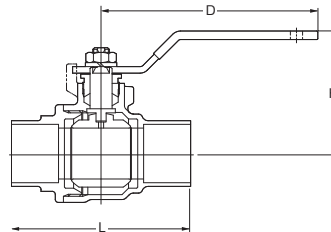

### Materials

Parts	Material
Body	Forged Brass/Cast Bronze*
Body cap	Forged Brass/Cast Bronze*
Stem	Dezincification resistant brass
Ball	Forged Brass: SnNi plated (NPS 3/8 to 1) Forged Brass: TEA® plated (NPS 1 1/4 to 3)
Ball seat	PTFE
Gland packing	PTFE

⚠ Solder joint end valves should not be used in service where the temperature of the line fluid is higher than the softening point of the solder.

### Dimensions of CTAF

Nominal Size	NPS DN	3/8	1/2	3/4	1	1 1/4	1 1/2	2	2 1/2	3
		10	15	20	25	32	40	50	65	80
L		46	54	73	88	100	115	140	163	187
H		39	42	51	59	64	73	80	108	122
D		82	82	100	130	130	150	150	200	300

Unit: mm



Refer to "Product Range" on Page 8.

## Type 600 Brass Ball Valves (Full Bore)

W.O.G. non-shock 4.12 MPa (600 psi), Saturated steam pressure 1.03 MPa (150 psi)

Maximum pressure temperature limitation: 150 psi at 300°F

Screwed body cap, Blowout-proof stem,  
Double O-ring stem seals,  
Threaded ends to NPT or solder joint ends

### AKTFLL

- Threaded end to ASME B1.20.1

### CTFLL

- Solder joint end to ASME B16.18

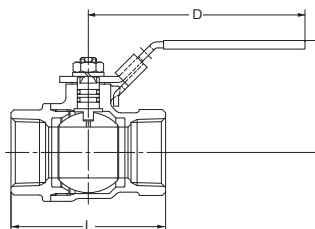

### Materials

Parts	Material
Body	Forged Brass
Body cap	Forged Brass
Stem	Dezincification resistant brass
Ball	Forged Brass: Cr plating
Ball seat	PTFE
O-ring	NBR, FKM

⚠ Solder joint end valves should not be used in service where the temperature of the line fluid is higher than the softening point of the solder.

### Dimensions of AKTFLL, CTFLL

Nominal Size	NPS DN	1/4	3/8	1/2	3/4	1	1 1/4	1 1/2	2
		8	10	15	20	25	32	40	50
L		41	42	53	60	72	82	92	105
L1 (Solder)				54	73	88	100	115	140
H		35	35	39	47	55	59	67	75
D		82	82	82	100	130	130	150	150

Unit: mm



\*AKTFLL only \*\*CTFLL only

## Type 600 Brass Ball Valves (Full Bore)

W.O.G. non-shock 4.12 MPa (600 psi), Saturated steam pressure 1.03 MPa (150 psi)

Stainless steel trim,  
Screwed body cap, Blowout-proof stem,  
Threaded ends to NPT or solder joint ends

### AKTAFM

• Threaded end to ASME B1.20.1

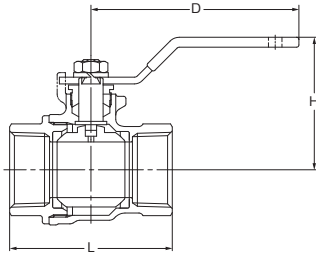

### Materials

Parts	Material
Body	Forged Brass
Body cap	Forged Brass
Stem	Stainless steel (A276 Type 316)
Ball	Stainless steel (A276 Type 316 or A351 Gr. CF8M)
Ball seat	PTFE
Gland packing	PTFE

⚠ Solder joint end valves should not be used in service where the temperature of the line fluid is higher than the softening point of the solder.

### Dimensions of AKTAFM

Nominal Size	NPS DN	1/4	3/8	1/2	3/4	1	1 1/4	1 1/2	2
		8	10	15	20	25	32	40	50
L		41	42	53	60	72	82	92	105
L1 (Solder)			46	54	73	88	100	115	140
H		39	39	42	51	59	64	73	80
D		82	82	82	100	130	130	150	150

Unit: mm

## Type 600 Brass Ball Valves (Full Bore)

W.O.G. non-shock 4.12 MPa (600 psi), Saturated steam pressure 0.98 MPa (150 psi)

Mounting pad,  
Screwed body cap, Blowout-proof stem,  
Threaded ends to ASME B1.20.1

### AKTAFP

• Threaded end to ASME B1.20.1

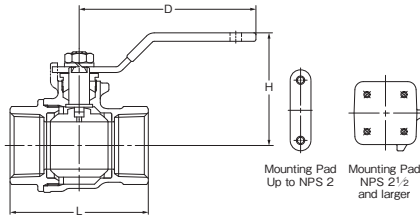
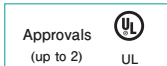

### Materials

Parts	Material
Body	Forged Brass/Cast Bronze*
Body cap	Forged Brass/Cast Bronze*
Stem	Dezincification resistant brass
Ball	Forged Brass: Cr plating
Ball seat	PTFE
Gland packing	PTFE

\*NPS 2 1/2 and larger

### Dimensions of AKTAFP

Nominal Size	NPS DN	1/4	3/8	1/2	3/4	1	1 1/4	1 1/2	2	2 1/2	3	4
		8	10	15	20	25	32	40	50	65	80	100
L		41	42	53	60	72	82	92	105	135	156	192
H		39	39	42	51	59	64	73	80	108	122	140
D		82	82	82	100	130	130	150	150	200	300	300

Unit: mm

## Type 600 Brass Ball Valves (Full Bore)

W.O.G. non-shock 4.12 MPa (600 psi), Saturated steam pressure 1.72 MPa (250 psi)

250 WSP steam trim, Mounting pad,  
Screwed body cap, Blowout-proof stem,  
Threaded ends to ASME B1.20.1

### AKTAFPM

• Threaded end to ASME B1.20.1

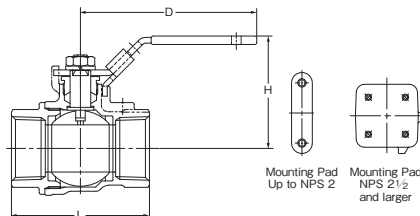
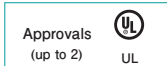

### Materials

Parts	Material
Body	Forged Brass/Cast Bronze*
Body cap	Forged Brass/Cast Bronze*
Stem	Stainless steel (A276 Type 316)
Ball	Stainless steel (A276 Type 316 or A351 Gr. CF8M)
Ball seat	Reinforced PTFE
Gland packing	Reinforced PTFE

\*NPS 2 1/2 and larger

### Dimensions of AKTAFPM

Nominal Size	NPS DN	1/4	3/8	1/2	3/4	1	1 1/4	1 1/2	2	2 1/2	3	4
		8	10	15	20	25	32	40	50	65	80	100
L		41	42	53	60	72	82	92	105	135	156	192
H		39	39	42	51	59	64	73	80	108	122	140
D		82	82	82	100	130	130	150	150	200	300	300

Unit: mm

## Type 600 Brass Ball Valves (Full Bore)

W.O.G. non-shock 4.12 MPa (600 psi), Saturated steam pressure 1.03 MPa (150 psi)

### AKTAFB

- Threaded end to ASME B1.20.1

### CTAFB

- Solder joint end to ASME B16.18

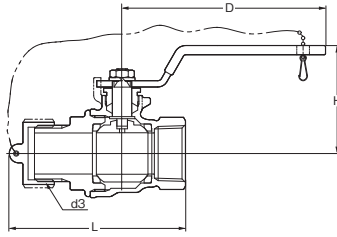

Threaded end  $\frac{3}{4}$  Hose connection, with cap & chain, Blowout-proof stem, Threaded/Hose connection (ASME B1.20.1/ASME B1.20.7  $\frac{3}{4}$  11.5NHR)

### Materials

Parts	Material
Body	Forged Brass
Body cap	Forged Brass
Stem	Dezincification resistant brass
Ball	Forged Brass: Cr plated
Ball seat	PTFE
Gland packing	PTFE



Solder joint end valves should not be used in service where the temperature of the line fluid is higher than the softening point of the solder. Unit: mm

### Dimensions of AKTAFB, CTAFB

Nominal Size	NPS	$\frac{1}{2}$	$\frac{3}{4}$
	DN	15	20
L		74	84
L1 (Solder)		75	90
H		42	51
D		82	100
d3		$\frac{3}{4}$ -11.5 NHR	$\frac{3}{4}$ -11.5 NHR

## Type 600 Brass Ball Valves (Full Bore)

W.O.G. non-shock 4.12 MPa (600 psi), Saturated steam pressure 1.03 MPa (150 psi)

### AKTAFO

- Threaded end to ASME B1.20.1

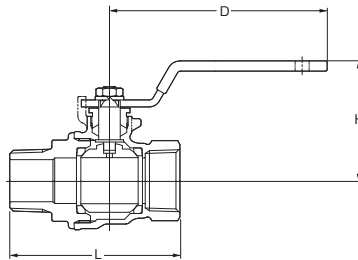

Screwed body cap, Blowout-proof stem, Male & Female, Threaded ends to ASME B1.20.1

### Materials

Parts	Material
Body	Forged Brass
Body cap	Forged Brass
Stem	Dezincification resistant brass
Ball	Forged Brass: Cr plated
Ball seat	PTFE
Gland packing	PTFE

### Dimensions of AKTAFO

Nominal Size	NPS	$\frac{1}{4}$	$\frac{3}{8}$	$\frac{1}{2}$	$\frac{3}{4}$	1
	DN	8	10	15	20	25
L		52	53	66	73	88
H		39	39	42	51	59
D		82	82	82	100	130

## Type 600 Brass Ball Valves (Full Bore)

W.O.G. non-shock 4.12 MPa (600 psi), Saturated steam pressure 1.03 MPa (150 psi)

### AKTAFU

- Threaded end to ASME B1.20.1

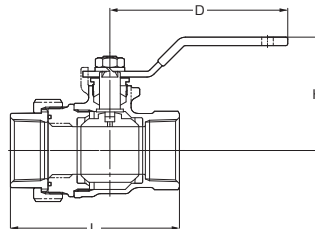

Single union, Screwed body cap, Blowout-proof stem, Threaded ends to ASME B1.20.1

### Materials

Parts	Material
Body	Forged Brass
Body cap	Forged Brass
Stem	Dezincification resistant brass
Ball	Forged Brass: Cr plated
Ball seat	PTFE
Gland packing	PTFE

### Dimensions of AKTAFU

Nominal Size	NPS	$\frac{1}{4}$	$\frac{3}{8}$	$\frac{1}{2}$	$\frac{3}{4}$	1	$1\frac{1}{4}$	$1\frac{1}{2}$	2
	DN	8	10	15	20	25	32	40	50
L		52	52	63	75	88	98	113	126
H		39	39	42	51	59	64	73	80
D		82	82	82	100	130	130	150	150

## Type 200 Brass Ball Valves (Full Bore)

W.O.G. non-shock 1.37 MPa (200 psi), -18°C to + 93°C (Avoid freezing the valve)

Safety exhaust, Screwed body cap, Blowout-proof stem, Latch lock handle, Threaded ends to ASME B1.20.1

### AKTAFS

- Threaded end to ASME B1.20.1

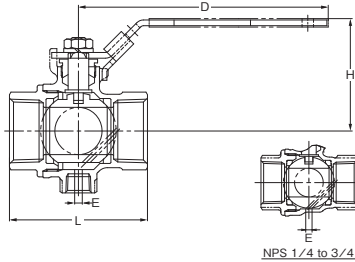

### Materials

Parts	Material
Body	Forged Brass
Body cap	Forged Brass
Stem	Dezincification resistant brass
Ball	Forged Brass: Cr plated
Ball seat	PTFE
Gland packing	PTFE

### Dimensions of AKTAFS

Unit: mm

Nominal Size	NPS	1/4	3/8	1/2	3/4	1	1 1/4	1 1/2	2
	DN	8	10	15	20	25	32	40	50
L		41	42	53	60	72	82	92	105
H		39	39	42	51	59	64	73	80
E		4	4	4	4	4	4	4	4
D		82	82	82	100	130	130	150	150

● Exhaust hole diameter: 4 mm (all nominal size)

## Type 400/600 Brass Ball Valves (Standard Bore)

CTH W.O.G. non-shock 4.12 MPa (600 psi), W.O.G. 150°C non-shock 0.69 MPa (100 psi)  
TH W.O.G. non-shock 2.75 MPa (400 psi), W.O.G. 150°C non-shock 0.69 MPa (100 psi)

Screwed body cap, Blowout-proof stem, Double O-ring stem seals, Threaded ends to JIS B0203 (BS21) or solder joint ends

### TH\*

- Threaded end to JIS B0203 (BS21)

### CTH

- Solder joint end to ASME B16.18

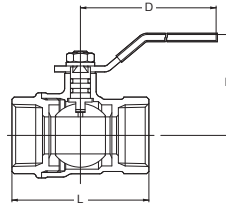
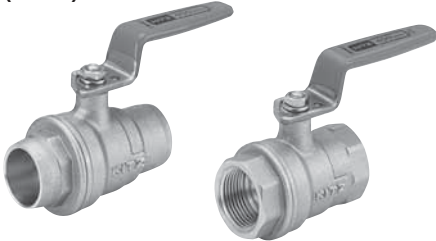

### Materials

Parts	Material
Body	Forged Brass
Body cap	Forged Brass
Stem	Dezincification resistant brass
Ball	Forged Brass*/SCS13A**
Ball seat	PTFE
O-ring	FKM

\*Cr plated (up to NPS 1 1/4, 3) \*\*NPS 1 1/2~2 1/2

⚠ Solder joint end valves should not be used in service where the temperature of the line fluid is higher than the softening point of the solder.

### Dimensions of TH, CTH

Unit: mm

Nominal Size	NPS	1/4	3/8	1/2	3/4	1	1 1/4	1 1/2	2	2 1/2	3
	DN	8	10	15	20	25	32	40	50	65	80
L		44	45	56	63	74	82	91	104	-	-
L1 (Solder)		47	47	54	73	88	98	113	135	147	177
H		41	41	45	48	54	58	63	74	89	103
D		60	60	80	80	110	110	110	140	200	300

\*TH: NPS 1/4 to 2

\*The length of useful threads and the positions of gauge planes are built on KITZ standard. Taper pipe threads for connection shall refer to JIS B0203 standards.

## Type 400 Brass Ball Valves (Standard Bore)

W.O.G. non-shock 2.75 MPa (400 psi), W.O.G. 150°C 0.69 MPa (100 psi)

Screwed body cap, Blowout-proof stem, Double O-ring stem seals, Threaded ends to JIS B0203 (BS21) or NPT

### T\*

- Threaded end to JIS B0203 (BS21)

### TT\*

- Threaded end to JIS B0203 (BS21)

### AKT

- Threaded end to ASME B1.20.1

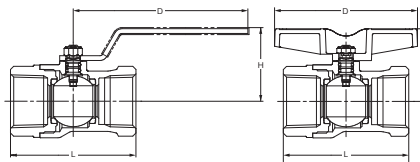

### Materials

Parts	Material
Body	Brass/Bronze*
Body cap	Brass/Bronze*
Stem	Dezincification resistant brass
Ball	Brass**
Ball seat	PTFE
O-ring	FKM

\*NPS 4 only

\*\*Nickel-chrome plated

### Dimensions of T, TT, AKT

Unit: mm

Nominal Size	NPS	1/4	3/8	1/2	3/4	1	1 1/4	1 1/2	2	2 1/2	3	4
	DN	8	10	15	20	25	32	40	50	65	80	100
L		50	50	65	68	79	86	96	109	127	153	179
L1		50	50	65	68	79	86	96	109	-	-	-
H		39	39	39	42	46	51	56	65	82	105	124
H1		34	34	37	40	46	52	57	71	-	-	-
D		60	60	80	80	110	110	110	140	200	300	400
D1		65	65	80	80	90	105	105	120	-	-	-

\*TT: 1/4 to 2

\*The length of useful threads and the positions of gauge planes are built on KITZ standard. Taper pipe threads for connection shall refer to JIS B0203 standards.



## Type 400 Brass Ball Valves (Standard Bore)

W.O.G. non-shock 2.8 MPa (400 psi), W.O.G. 150°C 0.7 MPa (100 psi)

### TO

- Threaded end to JIS B0203 (BS21)

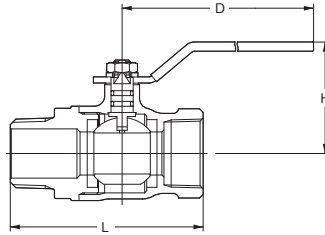

Screwed body cap, Blowout-proof stem,  
Double O-ring stem seals,  
Male & Female Threaded ends to JIS B0203 (BS21)

### Materials

Parts	Material
Body	Forged Brass
Body cap	Forged Brass
Stem	Dezincification resistant brass
Ball	Forged Brass*
Ball seat	PTFE
O-ring	FKM

\*Nickel-chrome plated

### Dimensions of TO

Unit: mm

Nominal Size	NPS	1/4	3/8	1/2	3/4	1
	DN	8	10	15	20	25
L		59	60	74	80	94
H		39	39	39	42	46
D		60	60	80	80	110

## Type 400 Brass Ball Valves (Standard Bore)

W.O.G. non-shock 2.75 MPa (400 psi), W.O.G. 150°C 0.69 MPa (100 psi)

### TM\*

- Threaded end to JIS B0203 (BS21)

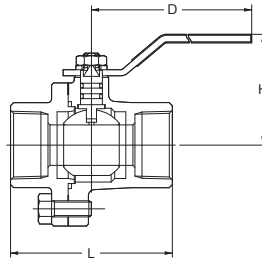

Bolted body and cap, Blowout-proof stem,  
Double O-ring stem seals, Threaded ends to JIS B0203 (BS21)

### Materials

Parts	Material
Body	Forged Brass
Body cap	Forged Brass
Stem	Dezincification resistant brass
Ball	Forged Brass*/SCS13A**
Ball seat	PTFE
O-ring	FKM

\*Cr plated \*\*NPS 2 1/2 only

### Dimensions of TM

Unit: mm

Nominal Size	NPS	3/8	1/2	3/4	1	1 1/4	1 1/2	2	2 1/2	3
	DN	10	15	20	25	32	40	50	65	80
L		56	60	68	80	86	101	117	136	160
H		45	45	49	55	60	65	75	91	105
D		60	80	80	110	110	110	140	200	300

\*The length of useful threads and the positions of gauge planes are built on KITZ standard.  
Taper pipe threads for connection shall refer to JIS B0203 standards.

## Type 600 Brass Ball Valves (Reduced bore)

W.O.G. non-shock 4.12 MPa (600 psi), W.O.G. 150°C 0.98 MPa (142 psi)

### TK

- Threaded end to JIS B0203 (BS21)

### AKTK

- Threaded end to ASME B1.20.1
- AKTK NPS 1/4 to 2

### TKT

- Threaded end to JIS B0203 (BS21)

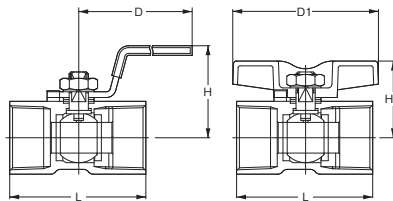
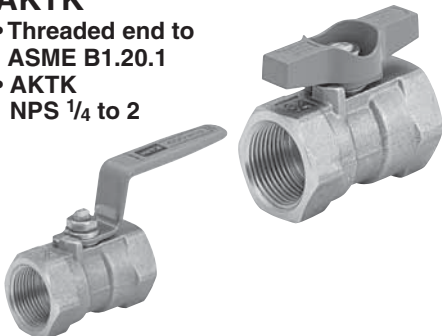

One-piece body, Blowout-proof stem,  
Threaded ends to JIS B0203 (BS21) or NPT

### Materials

Parts	Material
Body	Forged Brass
Body cap	Forged Brass
Stem	Dezincification resistant brass
Ball	Forged Brass*
Ball seat	G/F PTFE
Grand packing	G/F PTFE

\*Cr plated

### Dimensions of TK, TKT, AKTK

Unit: mm

Nominal Size	NPS	1/8	1/4	3/8	1/2	3/4	1	1 1/4	1 1/2	2
	DN	6	8	10	15	20	25	32	40	50
L		32	39	44	56.5	59	71	78	83	100
H		31	31	36	41	44	48	54	65	72
H1		23	23	27	31	34	42	48	53	60
D		60	60	70	85	85	100	100	125	125
D1		35	35	40	60	60	76	76	100	100



## Type 600 Brass Ball Valves (Reduced Bore)

W.O.G. non-shock 4.12 MPa (600 psi), W.O.G. 150°C 0.98 MPa (142 psi)

One-piece body, Blowout-proof stem, with Wing handle, Threaded ends to JIS B0203 (BS21)

### TKW

- Threaded end to JIS B0203 (BS21)

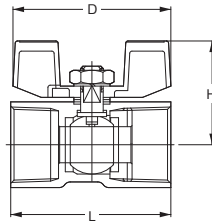

### Materials

Parts	Material
Body	Forged Brass
Body cap	Forged Brass
Stem	Dezincification resistant brass
Ball	Forged Brass*
Ball seat	G/F PTFE
Grand packing	G/F PTFE

\*Cr plated

### Dimensions of TKW

Unit: mm

Nominal Size	NPS DN	1/8	1/4	3/8	1/2	3/4	1
		6	8	10	15	20	25
L		32	39	44	56.5	59	71
H		25	25	29	35	39	41
D		35	35	40	55	55	69

## Type 400 Brass Ball Valves (Full Bore)

W.O.G. non-shock 2.75 MPa (400 psi), W.O.G. 150°C 0.69 MPa (100 psi)

Screwed body cap, Blowout-proof stem, Double O-ring stem seals, Threaded ends to JIS B0203 (BS21)

### TF

- Threaded end to JIS B0203 (BS21)

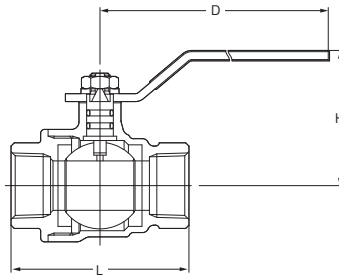

### Materials

Parts	Material
Body	Forged Brass/Cast Bronze*
Body cap	Forged Brass/Cast Bronze*
Stem	Dezincification resistant brass
Ball	Forged Brass**
Ball seat	PTFE
O-ring	FKM

\*NPS 2 only  
\*\*NiCr plated

### Dimensions of TF

Unit: mm

Nominal Size	NPS DN	1/2	3/4	1	1 1/4	1 1/2	2
		15	20	25	32	40	50
L		62	73	85	98	108	124
H		48	54	58	64	75	84
D		80	110	110	110	140	150

## Type 150 Brass Ball Valves (Full Bore)

W.O.G. non-shock 0.98 MPa (142 psi), W.O.G. 150°C 0.69 MPa (100 psi)

Locking device, Screwed body cap, Blowout-proof stem, Double O-ring stem seals, Threaded ends to JIS B0203 (BS21)

### TFJ

- Threaded end to JIS B0203 (BS21)

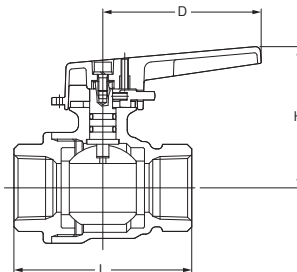

### Materials

Parts	Material
Body	Forged Brass/Cast Bronze*
Body cap	Forged Brass/Cast Bronze*
Stem	Dezincification resistant brass
Ball	Forged Brass**
Ball seat	PTFE
O-ring	FKM

\*NPS 2 only  
\*\*NiCr plated

### Dimensions of TFJ

Unit: mm

Nominal Size	NPS DN	1/2	3/4	1	1 1/4	1 1/2	2
		15	20	25	32	40	50
L		62	73	85	98	108	124
H		53	58	67	72	90	98.5
D		65	65	90	90	110	110

## Type 400 Brass Ball Valves (Standard Bore)

TL, CTL W.O.G. non-shock 2.75 MPa (400 psi), W.O.G. 150°C 0.69 MPa (100 psi),  
TLT W.O.G. non-shock 2.75 MPa (400 psi), W.O.G. 80°C 1.96 MPa (286 psi)

Screwed body cap, Blowout-proof stem,

Double O-ring stem seals,

Threaded ends to JIS B0203 (BS21) or solder joint ends

### TL

- Threaded end to JIS B0203 (BS21)



### CTL

- Solder joint end to ASME B16.18



### TLT

- Threaded end to JIS B0203 (BS21)

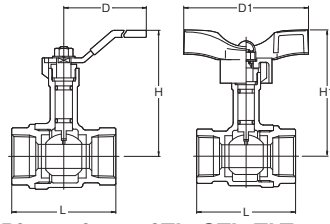

Dimensions of TL, CTL, TLT

Nominal Size	NPS DN	1/2	3/4	1	1 1/4	1 1/2	2
		15	20	25	32	40	50
L		56	65	78	86	96	109
L (Solder)		58	73	88	99	114	135
H		75	79	83	98	102	109
H1		79	83	90	105	109	124
D		80	80	110	110	110	140
D1		82	82	94	94	94	120

### Materials

Parts	Material
Body	Cast Bronze
Body cap	Cast Bronze
Stem	Dezincification resistant brass
Ball	SCS13A
Ball seat	PTFE
O-ring	FKM

⚠ Solder joint end valves should not be used in service where the temperature of the line fluid is higher than the softening point of the solder. Unit: mm

## Type 400 Brass Ball Valves (Standard Bore)

W.O.G. non-shock 2.75 MPa (400 psi), W.O.G. 80°C 1.96 MPa (286 psi)

Single union, Screwed body and cap,

Blowout-proof stem, Double O-ring stem seals,

Threaded ends to JIS B0203 (BS21) or solder joint ends

### CTLTU

- Solder joint end to ASME B16.18

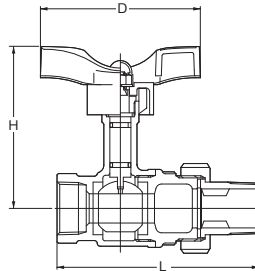

Dimensions of CTLTU

Nominal Size	in. mm	1/2	3/4	1
		15	20	25
L		90.5	103.5	119
L (Solder)		89.5	107.5	124
H		79	83	90
D		82	82	94

### Materials

Parts	Material
Body	Cast Bronze
Body cap	Cast Bronze
Stem	Dezincification resistant brass
Ball	SCS13A
Ball seat	PTFE
O-ring	FKM

⚠ Solder joint end valves should not be used in service where the temperature of the line fluid is higher than the softening point of the solder. Unit: mm

## Type 600 Brass Ball Valves (Full Bore)

W.O.G. non-shock 2.75 MPa (600 psi), W.O.G. 150°C 1.03 MPa (150 psi)

Three piece body with mounting pad,

Threaded end to ASME B1.20.1,

Solder jointed to ASME B16.18

### AK3TM

- Threaded end to ASME B1.20.1

### C3TM\*

- Solder joint end to ASME B16.18

\*C3TM NPS 3/8 to 2 1/2

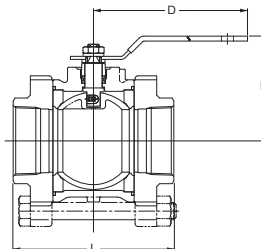

Dimensions of AK3TM, C3TM

Nominal Size	NPS DN	1/4	3/8	1/2	3/4	1	1 1/4	1 1/2	2
		8	10	15	20	25	32	40	50
L		49	49	61	70	83	99	117	139
L (Solder)		-	49	61	73	88	99	117	139
H		39	39	48	55	63	69	78	85
D		82	82	82	100	130	130	150	150

### Materials

Parts	Material
Body	Forged Brass
Body cap	Forged Brass
Stem	Dezincification resistant brass
Ball	Forged Brass: SnNi plated (NPS 1/4 to 1) TEA® plated (NPS 1/4 to 2)
Ball seat	PTFE
Grand packing	PTFE

⚠ Solder joint end valves should not be used in service where the temperature of the line fluid is higher than the softening point of the solder. Unit: mm

Refer to "Product Range" on Page 8.

## Type 600 Brass Ball Valves (Full Bore)

W.O.G. non-shock 4.12 MPa (600 psi), W.O.G. 150°C 0.98 MPa (142 psi)

**ZO**

• Threaded end to JIS B0203 (BS21)

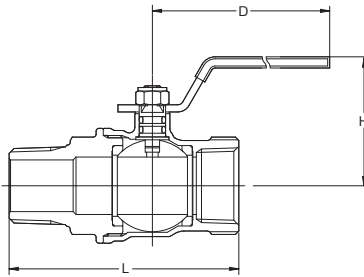

Screwed body cap, Blowout-proof stem,  
Double O-ring stem seals,  
Male & Female threaded ends to JIS B0203 (BS21)

### Materials

Parts	Material
Body	Forged Brass
Body cap	Forged Brass
Stem	Forged Brass: Ni plated
Ball	Forged Brass*
Ball seat	PTFE
O-ring	FKM

\*NiCr plated

### Dimensions of ZO

Unit: mm

Nominal Size	NPS DN	1/4	3/8	1/2	3/4	1
		8	10	15	20	25
L		59	60	74	80	94
H		37	37	40	44	50
D		70	70	80	80	110

## Type 400 Brass Ball Valves (Standard Bore)

W.O.G. non-shock 2.75 MPa (400 psi), W.O.G. 150°C 0.69 MPa (100 psi), Saturated steam pressure 0.98 MPa (142 psi)

**ZS\***

• Threaded end to JIS B0203 (BS21)

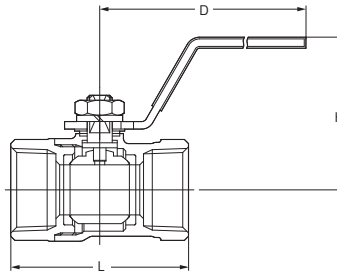

Screwed body cap, Blowout-proof stem,  
Threaded ends to JIS B0203 (BS21)

### Materials

Parts	Material
Body	Forged Brass
Body cap	Forged Brass
Stem	Dezincification resistant brass
Ball	Forged Brass*/SCS13A**
Ball seat	PTFE
Grand packing	G/F PTFE

\*Cr plated \*\*NPS 1 1/2 only

### Dimensions of ZS

Unit: mm

Nominal Size	NPS DN	1/4	3/8	1/2	3/4	1	1 1/4	1 1/2	2
		8	10	15	20	25	32	40	50
L		42	43	51	59	71	78	88	99
H		44	44	45	49	63	67	71	76
D		72	72	87	87	116	116	117	117

\*The length of useful threads and the positions of gauge planes are built on KITZ standard.  
Taper pipe threads for connection shall refer to JIS B0203 standards.

## Type 600 Brass Ball Valves (Full Bore)

W.O.G. non-shock 4.12 MPa (600 psi), W.O.G. 150°C 0.98 MPa (142 psi)

**ZET**

• Threaded end to JIS B0203 (BS21)

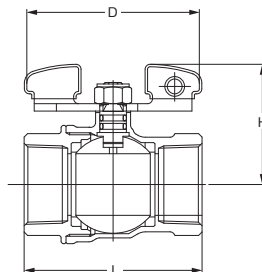
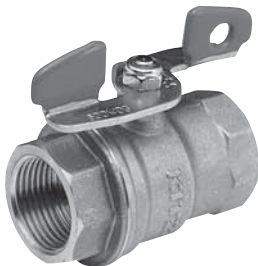

Screwed body cap, Blowout-proof stem,  
Double O-ring stem seals,  
Threaded ends to JIS B0203 (BS21)

### Materials

Parts	Material
Body	Forged Brass
Body cap	Forged Brass
Stem	Brass: Ni plated
Ball	Forged Brass*/SCS13A**
Ball seat	PTFE
O-ring	FKM

\*NiCr plated \*\*NPS 1 1/4 or 2

### Dimensions of ZET

Unit: mm

Nominal Size	NPS DN	1/4	3/8	1/2	3/4	1	1 1/4	1 1/2	2
		8	10	15	20	25	32	40	50
L		42	42	53	60	72	84	92	110
H		35	35	41	45	54	59	75	82
D		55	55	70	70	100	100	130	130

## Type 600 Brass Ball Valves (Full Bore)

W.O.G. non-shock 4.12 MPa (600 psi)\*, W.O.G. 150°C 1.03 MPa (150 psi)

### AKSZA

- Threaded end to ASME B1. 20. 1

### CSZA

- Solder joint to ASMB 16.18

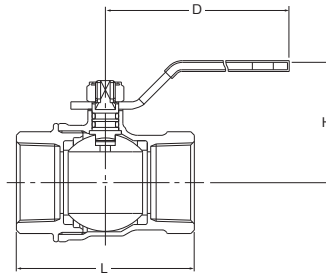

Screwed body and cap, Blowout-proof stem, Double O-ring stem seals, Threaded ends to ASME B1.20.1 or solder joint ends

\*NPS 4 : W.O.G. non-shock 2.8 MPa (400 psi), W.O.G. 150°C 0.7 MPa (100 psi)

### Materials

Parts	Material
Body	Brass/Bronze*
Body cap	Brass/Bronze*
Stem	Brass: Nickel plated
Ball	Forged Brass: SnNi plated (NPS 1/4 to 1) TEA® plated (NPS 1 1/4 to 2 1/2) Brass: NiCr plated (NPS 4) SCS13A (NPS3)
Ball seat	PTFE
O-ring	FKM

\*NPS 4 only

⚠ Solder joint end valves should not be used in service where the temperature of the line fluid is higher than the softening point of the solder.

### Dimensions of AKSZA, CSZA

Nominal Size	NPS DN	1/4	3/8	1/2	3/4	1	1 1/4	1 1/2	2	2 1/2	3	4
		8	10	15	20	25	32	40	50	65	80	100
L		42	42	53	60	72	84	92	110	138	167	193
L1 (Solder)			46	54	73	88	100	115	140	164	187	
H		37	37	40	44	50	55	65	72	101	113	131
D		70	70	80	80	110	110	150	150	200	300	300

Refer to "Product Range" on Page 8.

## Type 600 Brass Ball Valves (Full Bore)

W.O.G. non-shock 4.12 MPa (600 psi), W.O.G. 150°C 1.03 MPa (150 psi)

### SZA

- Threaded end to JIS B0203 (BS21)

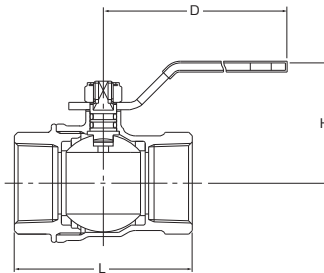

Screwed body and cap, Blowout-proof stem, Double O-ring stem seals, Threaded ends to JIS B0203 (BS21)

### Materials

Parts	Material
Body	Forged Brass
Body cap	Forged Brass
Stem	Brass: Ni plated
Ball	Forged Brass*
Ball seat	PTFE
O-ring	FKM

\*NiCr plated

### Dimensions of SZA

Nominal Size	NPS DN	1/4	3/8	1/2	3/4	1	1 1/4	1 1/2	2	2 1/2	3	4
		8	10	15	20	25	32	40	50	65	80	100
L		42	42	53	60	72	84	92	110	138	167	193
H		37	37	40	44	50	55	65	72	101	113	131
D		70	70	80	80	110	110	150	150	200	300	300

## Type 600 Brass Ball Valves (Full Bore)

W.O.G. non-shock 4.12 MPa (600 psi), W.O.G. 150°C 1.03 MPa (150 psi)

### AKSZAW

- Threaded end to ASME B1. 20. 1

### CSZAW

- Solder joint to ASME B16.18

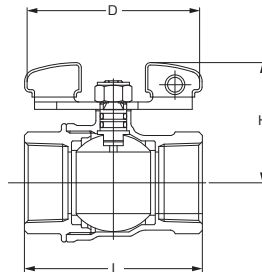

Screwed body and cap, Blowout-proof stem, Double O-ring stem seals, Threaded ends to ASME B1.20.1 or solder joint ends to ASME B16.18.

### Materials

Parts	Material
Body	Forged Brass
Body cap	Forged Brass
Stem	Brass: Ni plated
Ball	Brass: SnNi plated (NPS 1/4 to 1) TEA® plated (NPS 1 1/4 to 2)
Ball seat	PTFE
O-ring	FKM

### Dimensions of AKSZAW, CSZAW

Nominal Size	NPS DN	1/4	3/8	1/2	3/4	1	1 1/4	1 1/2	2
		8	10	15	20	25	32	40	50
L		42	42	53	60	72	84	92	110
L1 (Solder)			46	54	73	88	100	115	140
H		35	35	41	45	54	59	75	82
D		55	55	70	70	100	100	130	130

## Type 400 3-Way Brass Ball Valves (Standard Bore)

W.O.G. non-shock 2.75 MPa (400 psi), W.O.G. 150°C 0.69 MPa (100 psi)

TN\*

- Threaded end to JIS B0203 (BS21)

AKTN

- Threaded end to ASME B1.20.1



\*The length of useful threads and the positions of gauge planes are built on KITZ standard. Taper pipe threads for connection shall refer to JIS B0203 standards.

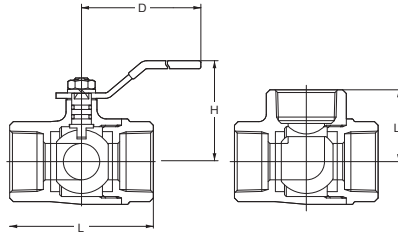

Screwed body cap, 2-seat, L-port design, Blowout-proof stem, Double O-ring stem seals\*, Threaded ends to JIS B0203 (BS21) or NPT, or solder joint ends  
\*NPS 1/2 and larger

### Materials

Parts	Material
Body	Forged Brass/Cast Bronze*
Body cap	Forged Brass
Stem	Dezincification resistant brass
Ball	Forged Brass**
Ball seat	PTFE
O-ring	FKM

\*NPS 2 1/2 and 3

\*\*Cr plated

⚠ Solder joint end valves should not be used in service where the temperature of the line fluid is higher than the softening point of the solder.

### Dimensions of TN, AKTN

Nominal Size	NPS DN	1/4	3/8	1/2	3/4	1	1 1/4	1 1/2	2	2 1/2	3
		8	10	15	20	25	32	40	50	65	80
L		40	46	67	68	79	89	100	115	138	166
L1		20	23	33.5	34	39.5	44.5	50	57.5	69	83
L1 (Solder)				28	37	44	50.5	59	71.5		
H		30	35	45	48	55	60	65	75	91	105
D		60	70	80	80	110	110	110	140	200	300

Unit: mm

Page 106 for Allowable Port Orientation.

## Type 400 3-Way Bronze Ball Valves (Standard Bore)

W.O.G. non-shock 2 MPa (290 psi), W.O.G. 150°C 0.62 MPa (90 psi)

T4T

- Threaded end to JIS B0203 (BS21)

T4L

- Threaded end to JIS B0203 (BS21)

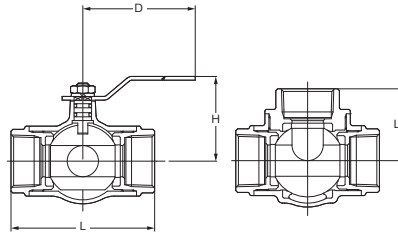

Screwed body cap, 4-seat, L or T-port design, Blowout-proof stem, Double O-ring stem seals, Threaded ends to JIS B0203 (BS21) or NPT

### Materials

Parts	Material
Body	Cast Bronze
Body cap	Forged Brass
Stem	Dezincification resistant brass
Ball	Brass*
Ball seat	PTFE
O-ring	FKM

\*Cr plated

Unit: mm

### Dimensions of T4T, T4L

Nominal Size	NPS DN	1/2	3/4	1	1 1/4	1 1/2	2
		15	20	25	32	40	50
L		70	85	100	115	130	150
L1		35	42.5	50	57.5	65	75
H		52	56	63	68	94.5	102
D		130	130	150	150	230	230

Page 106 for Allowable Port Orientation.

## Type 400 3-Way Bronze Ball Valves, with Mounting Pad (Standard Bore)

W.O.G. non-shock 2.75 MPa (400 psi), W.O.G. 150°C 0.69 MPa (100 psi)

AKTNP

- Threaded end to ASME B1.20.1

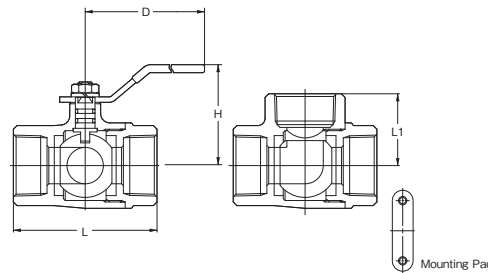

Screwed body cap, 2-seat, L-port design, Blowout-proof stem, Double O-ring stem seals, Threaded ends to NPT

### Materials

Parts	Material
Body	Forged Brass
Body cap	Forged Brass
Stem	Dezincification resistant brass
Ball	Forged Brass*
Ball seat	PTFE
O-ring	FKM

\*Cr plated

⚠ Solder joint end valves should not be used in service where the temperature of the line fluid is higher than the softening point of the solder.

Unit: mm

### Dimensions of AKTNP

Nominal Size	NPS DN	1/2	3/4	1	1 1/4	1 1/2	2
		15	20	25	32	40	50
L		67	68	79	89	100	115
L1		33.5	34	40	44.5	50	57.5
H		45	48	55	60	65	75
D		80	80	110	110	130	140

Page 106 for Allowable Port Orientation.

# Brass Ball Valves, Designed for Gas Service (Standard Bore)

Gas service 40°C 0.98 MPa (142 psi)

**TG\***

- Threaded end to JIS B0203 (BS21)

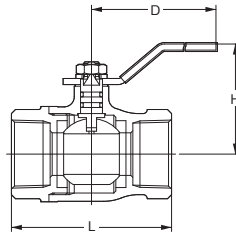

Screwed body cap,  
Blowout-proof stem, Double O-ring stem seals,  
Threaded ends to JIS B0203 (BS21)

### Materials

Parts	Material
Body	Forged Brass
Body cap	Forged Brass
Stem	Dezincification resistant brass
Ball	Forged Brass*/SCS13A**
Ball seat	PTFE
O-ring	NBR

\*NiCr plated \*\*NPS 1 1/2, 2

### Dimensions of TG

Nominal Size	NPS DN	1/4	3/8	1/2	3/4	1	1 1/4	1 1/2	2	2 1/2	3
		L	50	50	65	68	79	86	96	109	127
H	45	45	45	50	55	60	65	75	91	105	
D	60	60	80	80	110	110	110	140	200	300	

Unit: mm

\*The length of useful threads and the positions of gauge planes are built on KITZ standard.  
Taper pipe threads for connection shall refer to JIS B0203 standards.







# Technical Information

■ **KITZ Ball Seat Materials**

■ **Technical Data**

■ **Dimension of Actuator Mounting Pads**

■ **Pressure-Temperature Ratings**

■ **Allowable Port Orientation**

■ **General Precautions**

■ **Flow Characteristics**

## KITZ Ball Seat Materials

The following seat materials are available.

Material	Features	Maximum Service Temperature
Virgin PTFE	High chemical resistance and operation efficiency	200°C
HYPATITE® PTFE	Monomer permeability is lower and resistance against compression and creeping is higher than other PTFE materials	260°C /270°C *1
Carbon filled PTFE	Excellent heat and abrasion resistance	260°C /270°C *1
FILLTITE® *	Highest heat resistance among PTFE based materials	300°C *2
Graphite	Excellent for high temperature service	500°C
Metal	Excellent for high temperature and abrasive service	500°C /525°C *3
PEEK	Higher heat resistance and mechanical strength	270°C
Glass fiber filled PTFE with MoS <sub>2</sub>	Higher abrasion resistance and operation efficiency	230°C
Nylon with MoS <sub>2</sub>	Higher mechanical strength	140°C

\* : FILLTITE® is a specially reinforced ball seat, made by using more carbon based fillers into PTFE than conventional carbon filled PTFE, which greatly improves heat and abrasion resistance. The material shows excellent operability, durability, chemical resistance and sealing performance at a high temperature of 300°C. In addition, the ball seat is interchangeable with the most of our conventional ball seats, so it also has the cost advantage.

\*1 270°C: SCTDZ/UTDZM Series only.

\*2 Uni-body design: 260°C

\*3 525°C: T60M/SF3TC 6H UF3TC6HM Series only.

### HYPATITE® PTFE Ball Seats (Carbon and Stainless Steel Valves)

KITZ ball valves are furnished, as the manufacturer's standard, with HYPATITE® PTFE ball seats made of denatured PTFE, a molecularly reinforced PTFE copolymer, and specially engineered for high performance which include:

- Wide service temperature range of -29°C (-20°F) through 270°C (518°F) SCTDZ/UTDZ(M) Series, 260°C (500°F) UTB and SCTAZ/UTAZ(M) Series.  
This is for standard valve design and materials used for medium to high temperature services. The lower temperature range can be extended down to -196°C (-321°F) by means of extended bonnet design and special low temperature service materials.
- High chemical resistance comparable to virgin PTFE.
- Monomer permeability lower than other PTFE materials.
- High mechanical strength against compression and creeping (cold flow), superior to other PTFE materials for long life cycle.
- Smooth operation, as it possesses specific gravity and friction coefficient equal to those of virgin PTFE.
- Prevention of contamination for process line because of its stability, the performance comparable to virgin PTFE.
- High sealing performance brought by its resiliency, the typical feature of PTFE.

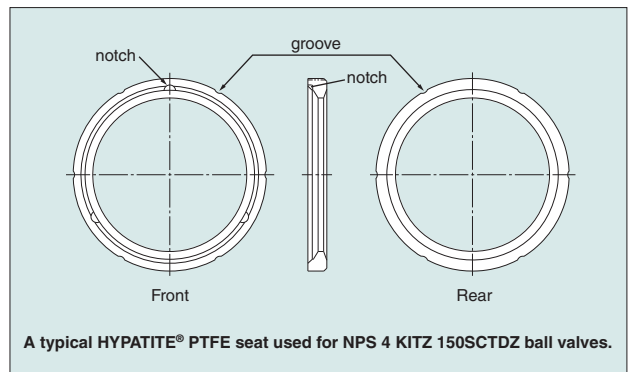

### FILLTITE® Ball Seats

Highest heat resistance among PTFE based materials.

- Service temperature range: -29°C to 300°C
- Trim symbol: 1H

## Technical Data

### 1. Choice of trim for heated abrasive service

Metal seated ball valves are guaranteed for a maximum service temperature of 300°C (572°F) (Trim symbol 5H) and 500°C (932°F) (Trim symbol 6H\*1\*2). For hard graphite seated ball valves, a maximum service temperature of 500°C (932°F) is also guaranteed (Trim symbol 3H\*2). Heat resistant sealing and trim materials qualify these valves for heated and abrasive service which cannot be properly handled by conventional soft seated ball valves due to the limited heat resistant characteristics and mechanical properties of their soft seats.

"FILLTITE<sup>®</sup>" is a specially reinforced ball seat, made by using more carbon based fillers into PTFE than conventional carbon filled PTFE, which greatly improves heat and abrasion resistance. The material shows excellent operability, durability, chemical resistance and sealing performance at a high temperature of 300°C. In addition, the ball seat is interchangeable with the most of our conventional ball seats, so it also has the cost advantage.

\*1 Temperature is limited to 450°C (842°F) for trunnion mounted ball valves with trim 6H

\*2 Shell material WCB: Upon prolonged exposure to temperatures above 425°C (797°F), the carbide phase of steel may be converted to graphite.

Permissible, but not recommended for prolonged usage above 425°C (797°F).

### 2. Unconditional fire-safe provision

While metal or hard graphite seats are extremely heat resistant, other sealing components such as gland packing and flange gaskets are made of flexible graphite, another heat resistant material, so that no part of the valve will be affected by extraordinarily heated environments. Also the provision of an anti-static device is not required because of inter-component electric conductivity.

### 3. Maintenance ease

Split body construction of the valve body provides the convenience of easy maintenance, a critical requirement for handling slurries and other viscous fluids.

### 4. Valve automation

Quarter-turn valve drive mechanism makes mounting of valve automation measures such as electric and pneumatic actuators technically easier. KITZ floating ball valves employ integral actuator mounting pads, complying with ISO 5211 and CAPI, for easy, safe and assured on-the-spot actuator mounting without disassembly of valve glands.

### 8. Metal seated ball valves (Trim 5H/6H)

Rigid construction with full metallic contact between the ball and seats, and high durability of trim materials make KITZ metal seated ball valves ideally suited to highly abrasive services handling slurries and other viscous fluids.

#### ● Trim materials

Valve Design	Floating Ball Valve		Trunnion Mounted Ball Valve	
	5H	6H *3	Split body	3-piece body
Trim symbol	5H	6H *3		6H
Temp.	300°C	500°C	450°C	525°C
	572°F	932°F	842°F	977°F
Seat leakage*1	ANSI FCI 70-2 Class VI		ISO 5208 RateD/ANSI FCI 70-2 Class VI *4	
Parts	Ball	ASTM A276 Type 316 or ASTM A351 CF8M + Cr plated	ASTM A276 Type 316 or A351 Gr.CF8M + SFNi *2	316 Stainless steel + SFNi *2
	Ball seat	ASTM A276 Type 316 + SFNi *2	ASTM A276 Type 316 + SFNi *2	316 Stainless steel + SFNi *2
	Stem	ASTM A 564 Type 630	ASTM A 564 Type 630	ASTM A276 Type304 + SFNi *2 ~343°C/649°F : ASTM A564 Type630 ~525°C/977°F : EN 1.4980

\*1 Maximum allowable seat leakage \*2 Ni-Cr alloy thermal spraying

\*3 Shell material WCB: Upon prolonged exposure to temperatures above 425°C (797°F), the carbide phase of steel may be converted to graphite. Permissible, but not recommended for prolonged usage above 425°C (797°F).

\*4 Please contact your local KITZ agents or distributors.

● Durable metal seat design and material also provides fully guaranteed throttling service performance, which makes KITZ metal seated ball valves function as a reliable control valve.

● Bi-directional flow.

#### Caution:

● Use a gear operator or valve actuator to fix the valve position when used for throttling service.

### 5. High flow efficiency

Full port design provides maximized and linear flow characteristic with minimal pressure loss as the line flow travels through the valve bore. This is a necessary design requirement particularly for trouble-free service of slurries and other viscous fluids.

### 6. FILLTITE<sup>®</sup> seated ball valves (Trim1H)

● Highest heat resistance among PTFE based materials.

Valve Design		Floating Ball Valve	Trunnion Mounted Ball Valve
Trim symbol		1H	
Temp.		300°C	
		572°F	
Parts	Ball	ASTM A276 Type 304*1 or A351 Gr.CF8*1	
	Ball seat	FILLTITE <sup>®</sup> PTFE	
	Stem	ASTM A276 Type 304*2 ASTM A276 Type 316*2	

\*1 Shell material CF8M; Ball Type 316 or CF8M

\*2 Shell material CF8M; Stem Type 316



### 7. Hard graphite seated ball valves (Trim 3H)

● Bi-directional flow.

● Recommended for low abrasion service.

Valve Design		Floating Ball Valve
Trim symbol		3H*5
Temp.		500°C
		932°F
Seat leakage*1		ANSI FCI 70-2 Class VI
Parts	Ball	ASTM A276 Type 304*1 or A351 Gr.CF8*2
	Ball seat	Carbon + JIS SUS329J1*3
	Stem	ASTM A276 Type 304*4

\*1 Maximum allowable seat leakage \*2 Shell material CF8M; Ball Type 316 or CF8M

\*3 Equivalent to AISI Type 329

\*4 Shell material CF8M; Stem Type 316

\*5 Shell material WCB: Upon prolonged exposure to temperatures above 425°C (797°F), the carbide phase of steel may be converted to graphite.

Permissible, but not recommended for prolonged usage above 425°C (797°F).

#### Caution:

● Not recommended for throttling service.

● Not recommended for high abrasion service.

● Maximum working temperature for oxidizing service, such as high temperature air, is 450°C (842°F).



## Dimension of Actuator Mounting Pads

### Integral Actuator Mounting Pads

KITZ 150/300 SCTDZ/UTDZ(M) series and 150/300 SCTAZM/UTAZ(M) series ball valves are furnished with an integral actuator mounting pad designed and factory-drilled according to ISO 5211 specification. This feature facilitates the installation of actuators with ISO 5211 mounting flange to the valves. Mounting pad and stem head dimension also conforms to CAPI ADDS 2.02.

**Note:** Customers are requested to prepare mounting brackets and connectors for the actuators chosen for their valve automation. Actuators can be mounted on KITZ ball valves without disassembly of valve glands.

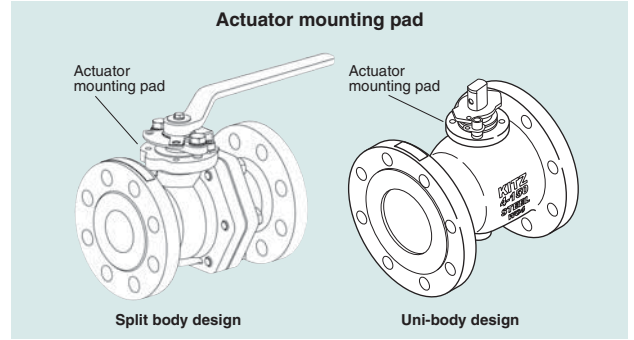

### Dimensions of ISO 5211 Actuator Mounting Pad for Class 150 / 300 Full Port, Split Body, Side Entry Design Ball Valves

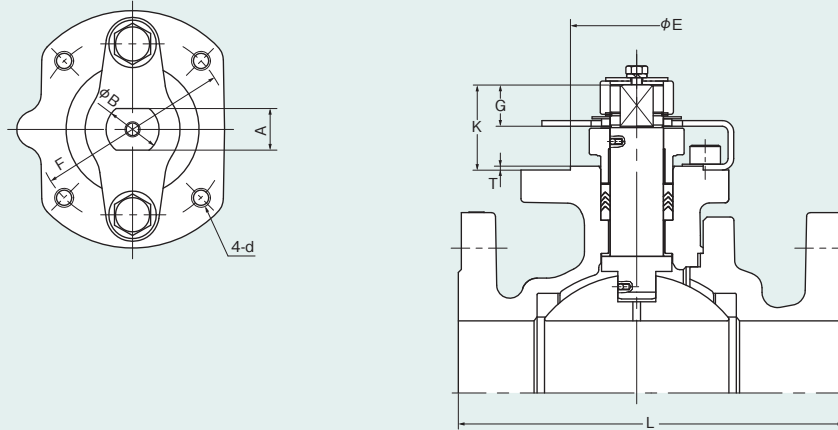

#### Dimensions

Unit: mm

Nominal Pressure	Nominal Size (NPS)	-0.05 -0.10 A	-0.1 -0.2 φB	-0.1 -0.2 φE	±0.2 φF	G	K	L	d	T	ISO 5211 Flange Type
									M Thread		
Class 150	1/2	9	12	25	36	9	22	108	M5	1	F03
	3/4	9	12	25	36	9	22	117	M5	1	F03
	1	14	18	35	50	14	30	127	M6	1.5	F05
	1 1/4	14	18	35	50	14	30	140	M6	1.5	F05
	1 1/2	17	22	55	70	17	34	165	M8	1.5	F07
	2	17	22	55	70	17	34	178	M8	1.5	F07
	2 1/2	22	28	70	102	22	45	190	M10	2	F10
	3	22	28	70	102	22	45	203	M10	2	F10
	4	27	36	85	125	27	52	229	M12	2	F12
	5	27	36	85	125	27	52	356	M12	2	F12
Class 300	6	36	48	100	140	36	63	394	M16	2	F14
	8	46	60	130	165	46	79	457	M20	2	F16
	10	46	60	130	165	46	79	533	M20	2	F16
	1/2	9	12	25	36	9	22	140	M5	1	F03
	3/4	9	12	25	36	9	22	152	M5	1	F03
	1	14	18	35	50	14	30	165	M6	1.5	F05
	1 1/2	17	22	55	70	17	34	190	M8	1.5	F07
	2	17	22	55	70	17	34	216	M8	1.5	F07
	2 1/2	22	28	70	102	22	45	241	M10	2	F10
	3	22	28	70	102	22	45	283	M10	2	F10
4	27	36	85	125	27	52	305	M12	2	F12	
6	36	48	100	140	36	63	403	M16	2	F14	
8	46	60	130	165	46	79	502	M20	2	F16	

**\*KITZ product codes:**

- (1) 150UTDZ(M)
- (2) 150SCTDZ
- (3) 300UTDZ(M)
- (4) 300SCTDZ
- (5) 150UTDZXL(M)
- (6) 300UTDZXL(M)

**Note:** Dimension of stem head are in accordance with CAPI ADDS 2.02, but the maximum specified dimension in CAPI ADDS 2.02 is "F14". For NPS 8 and 10, mounting pads are F16/ISO 5211.

## Dimension of Actuator Mounting Pads

### Dimensions of ISO 5211 Actuator Mounting Pad for Class 150 / 300 Reduced Bore, Uni-body, End Entry Design Ball Valves

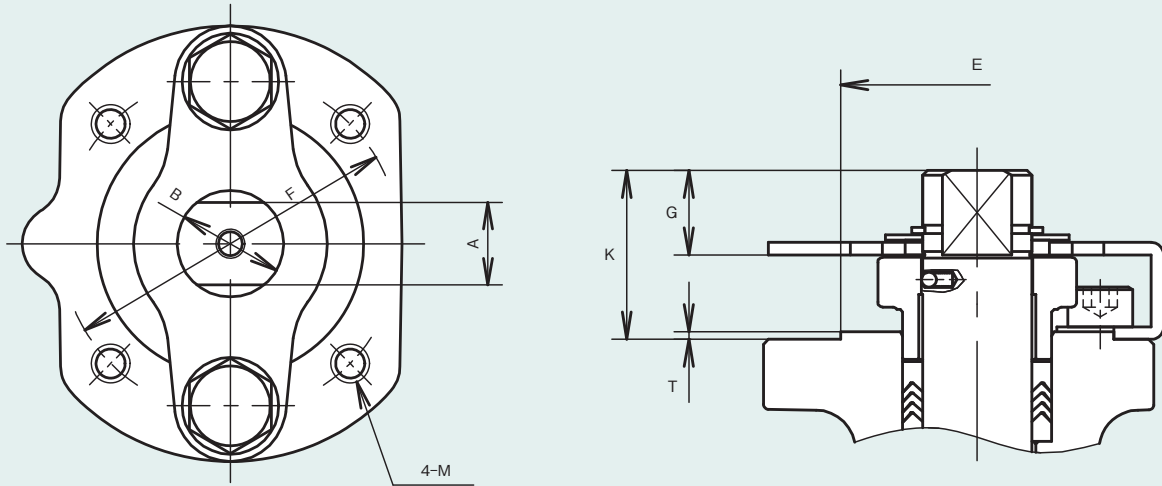

#### Dimensions

Unit: mm

Nominal Pressure	Nominal Size (NPS)	Mounting Dimensions for Actuator								ISO 5211 Flange Type
		A	B	E	F	G	K	T	M	
Class 150	1/2	7	10	25	36	8.5	18	1	M5	F03(2)
	3/4	7	10	25	36	8.5	18	1	M5	F03(2)
	1	9	12	25	36	9	22	1	M5	F03
	1 1/2	14	18	35	50	14	30	1.5	M6	F05
	2	17	22	55	70	17	34	1.5	M8	F07
	3	22	28	70	102	22	45	2	M10	F10
	4	22	28	70	102	22	45	2	M10	F10
	6	27	36	85	125	27	52	2	M12	F12
Class 300	8	36	48	100	140	36	63	2	M16	F14
	10	46	60	130	165	46	79	2	M20	F16
	1/2	7	10	25	36	8.5	18	1	M5	F03(2)
	3/4	7	10	25	36	8.5	18	1	M5	F03(2)
	1	9	12	25	36	9	22	1	M5	F03
	1 1/2	14	18	35	50	14	30	1.5	M6	F05
	2	17	22	55	70	17	34	1.5	M8	F07
	3	22	28	70	102	22	45	2	M10	F10
	4	22	28	70	102	22	45	2	M10	F10
	6	27	36	85	125	27	52	2	M12	F12
8	36	48	100	140	36	63	2	M16	F14	
10	46	60	130	165	46	79	2	M20	F16	

\* These dimensions are specified as F03S by CAPI.

★UNC threads optionally available.

#### KITZ product codes:

(1) 150SCTAZ (3) 300SCTAZ  
 (2) 150UTAZ(M) (4) 300UTAZ(M)

## Pressure-Temperature Ratings

The pressure-temperature ratings of ball valves are determined, not only by valve shell materials, but more essentially by sealing materials, used for ball seats, gland packing and gaskets. Sealing materials may be high molecule, or rubber, but the choice is limited by the characteristics of the service fluid, working temperatures, working pressures, velocity of fluid, and operational frequency of valves.

As it is very difficult to predetermine the exact pressure-temperature rating for all kinds of fluid under all imaginable conditions, we have prepared general rating charts for non-

shock fluid service here, based on our past experiences both in the field and in our laboratory.

In case of extraordinary service conditions as mentioned below, contact KITZ Corporation or its distributors for technical advice:

1. Valves shall be left fully closed for a long period of time under high temperature or high differential pressure.
2. Valves shall be frequently operated under high temperature or high differential pressure.
3. Frequent change of line pressure or temperature.

HYPATITE® PTFE is the standard seat material for KITZ ball valves. Specify virgin PTFE or carbon-filled PTFE when required. The body ratings shown here are for ASTM A216 Gr. WCB and A351 Gr. CF8M. For the pressure ratings of other valve shell materials, refer to the latest edition of ASME B16.34.

FILLTITE® is a specially reinforced ball seat, made by using carbon based fillers into PTFE at higher rate than conventional carbon filled PTFE, which greatly improves heat and abrasion resistance. The material shows excellent operability, durability, chemical resistance and sealing performance at a high temperature of 300 . In addition, the ball seat is interchangeable with the most of our conventional ball seats, so it also has the cost advantage.

### Soft Seated 3-Piece trunnion mounted ball valves

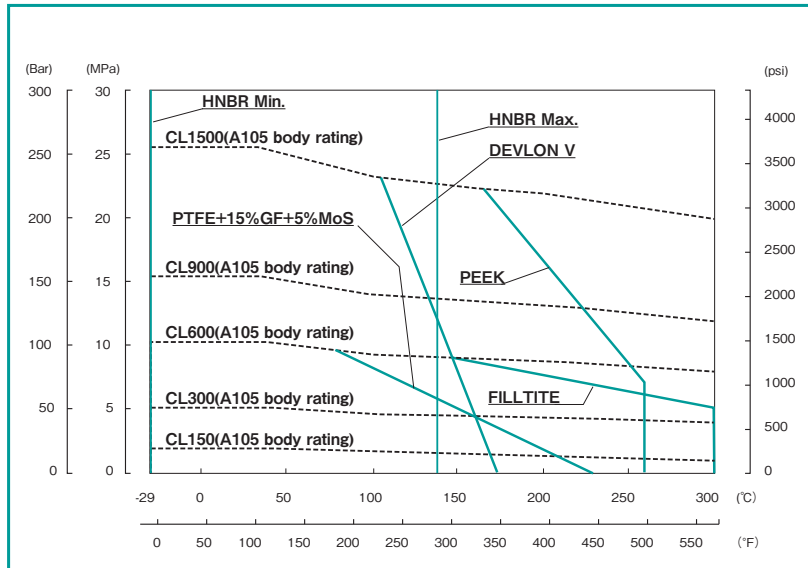

O-Ring Material	Min.Temp. (°C/F)	Max.Temp. (°C/F)
NBR	-30/-22	80/176
HNBR	-30/-22	140/284
L-NBR	-50/-58	80/176
L-HNBR	-46/-50	140/284
FKM	-20/-4	200/392

### Metal Seated 3-Piece trunnion mounted ball valves: Trim 6H

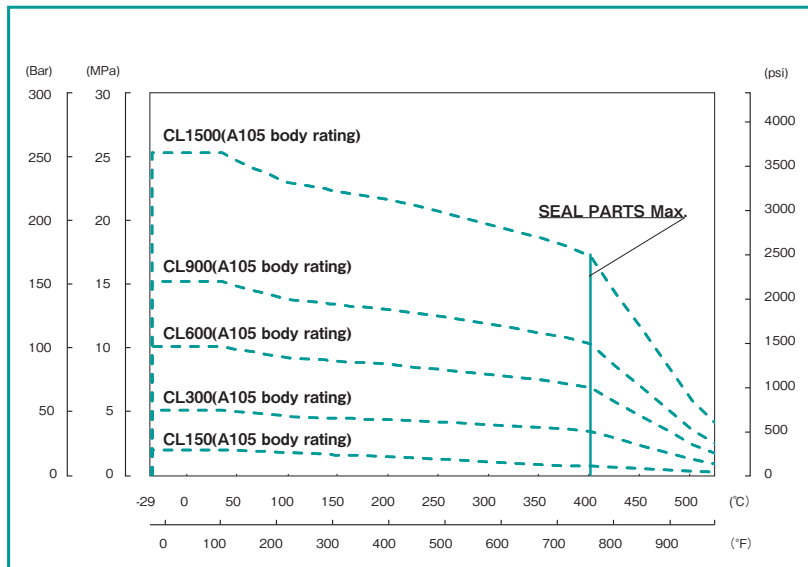

NOTE : In case of using at higher than 400°C please contact KITZ Corporation.

# Pressure-Temperature Ratings

150/300UTDZ(M)/SCTD : NPS 1/2, 3/4

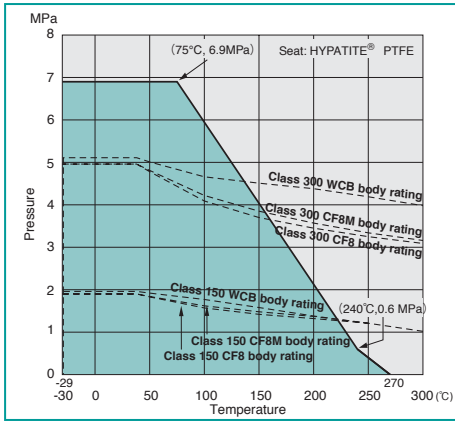

150/300UTDZ(M)/SCTD : NPS 1 to 2 1/2

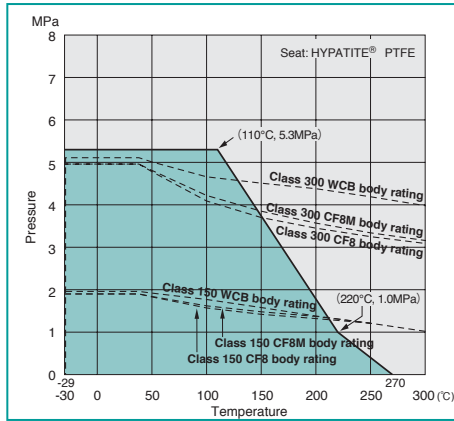

150/300UTDZ(M)/SCTD : NPS 3, 4

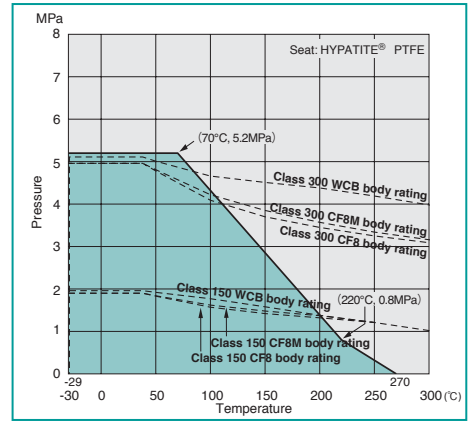

150/300UTDZ(M)/SCTD : NPS 5, 6

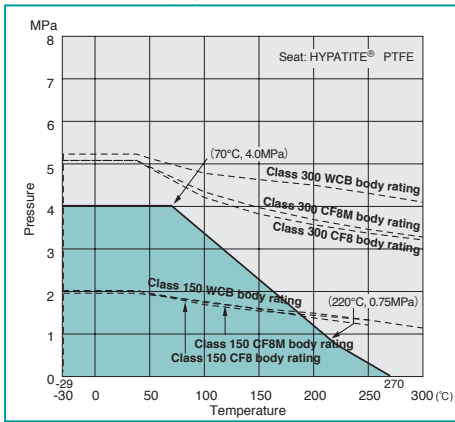

150/300UTDZ(M)/SCTD : NPS 8, 10

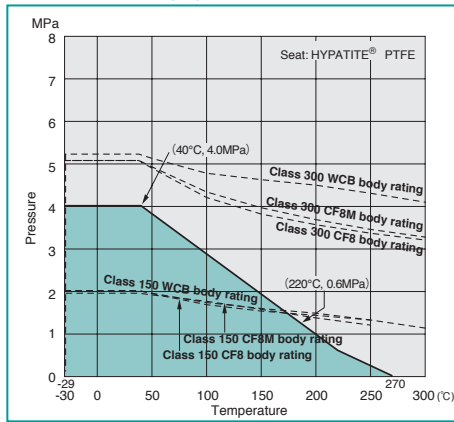

Note: Lowest working temperature for WCB is -29°C.

150/300UTAZ(M)/SCTAZM : NPS 1/2 to 1

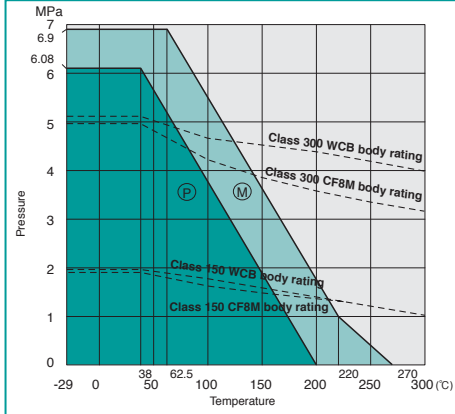

150/300UTAZ(M)/SCTAZM : NPS 1 1/2 to 3

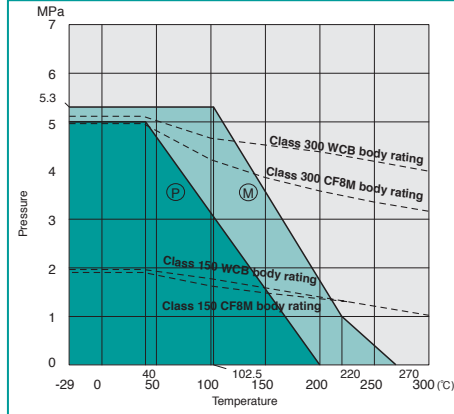

150/300UTAZ(M)/SCTAZM : NPS 4, 6

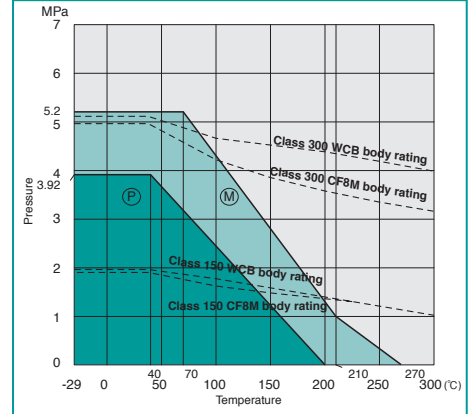

150/300UTAZ(M)/SCTAZM : NPS 8, 10

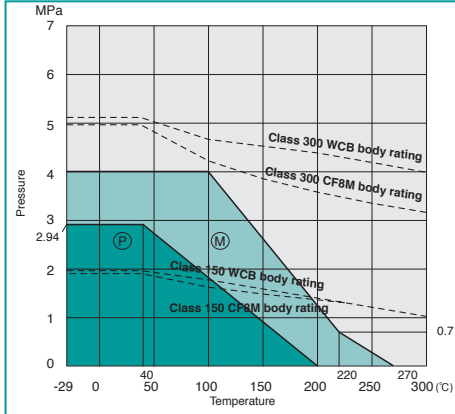

Seat: (P) Virgin PTFE  
(M) HYPATITE® PTFE / Carbon-filled PTFE

# Pressure-Temperature Ratings

## FILLTITE® seated floating ball valves: Trim 1H: NPS 1 to 2 1/2

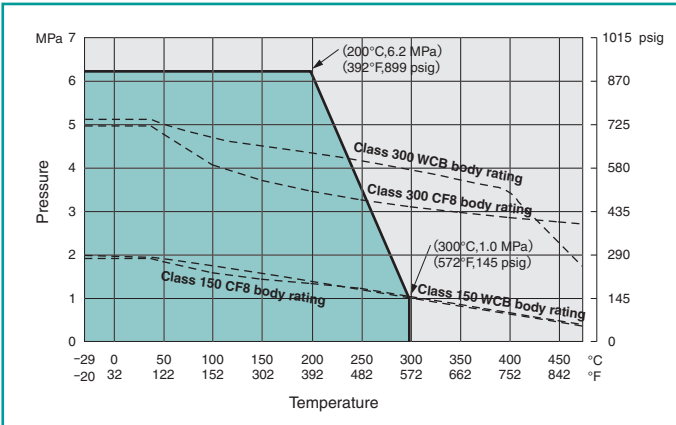

## FILLTITE® seated floating ball valves: Trim 1H: NPS 3, 4

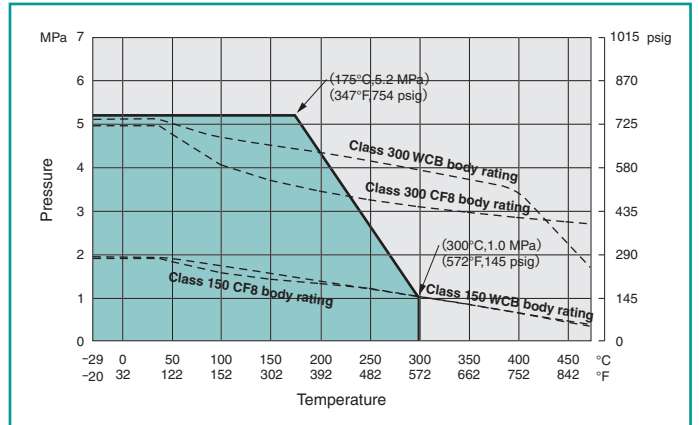

## FILLTITE® seated floating ball valves: Trim 1H: NPS 5, 6

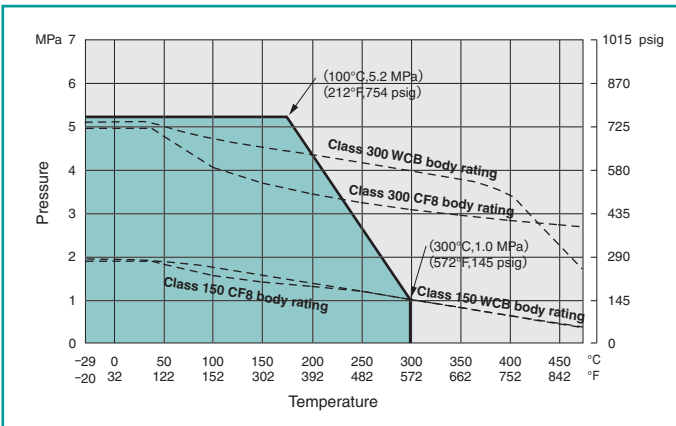

## FILLTITE® seated floating ball valves: Trim 1H: NPS 8, 10

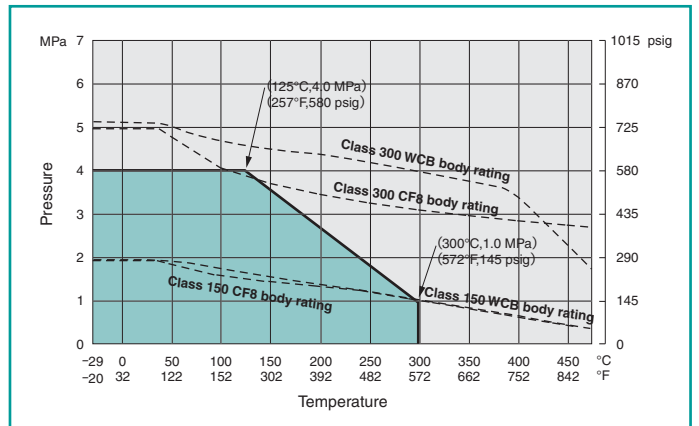

## Hard graphite seated floating ball valves: Trim 3H

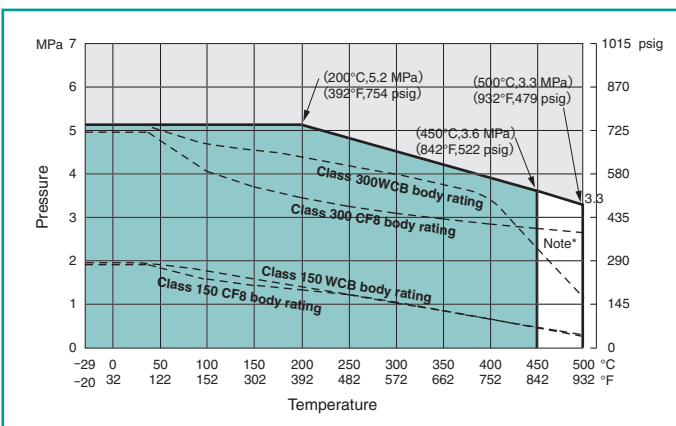

Note\* Maximum working temperature for oxidizing service, such as high temperature air, is 450°C (842°F).

Note: 3H Maximum working temperature for oxidizing service, such as high temperature air, is 450°C (842°F).

Note: 3H/6H Serviceable temperature terminates at 300°C (572°F) for JIS 10K and at 425°C (797°F) for JIS 20K.

Note: 3H/6H Shell material WCB: Upon prolonged exposure to temperatures above 425°C (797°F), the carbide phase of steel may be converted to graphite. Permissible, but not recommended for prolonged usage above 425°C (797°F).



# Pressure-Temperature Ratings

● Metal seated floating ball valves: Trim 5H: NPS 1/2 to 1 1/4

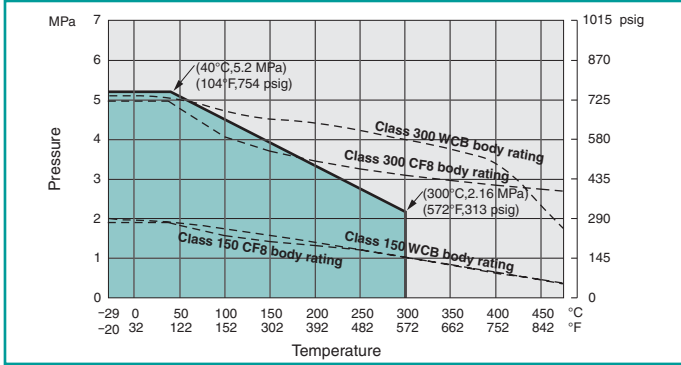

● Metal seated floating ball valves: Trim 5H: NPS 1 1/2, 2

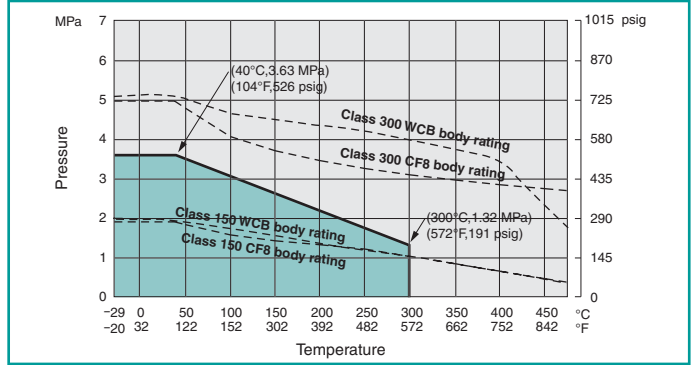

● Metal seated floating ball valves: Trim 5H: NPS 2 1/2, 4

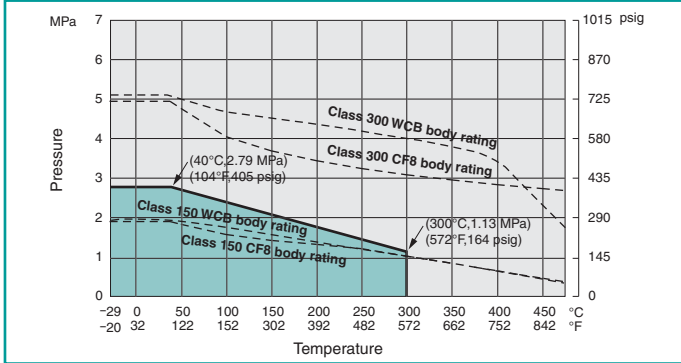

● Metal seated floating ball valves: Trim 5H: NPS 5 to 8

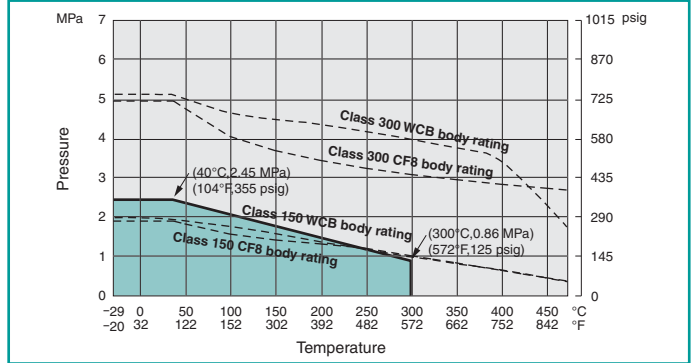

● Metal seated floating ball valves: Trim 6H: NPS 1/2 to 5

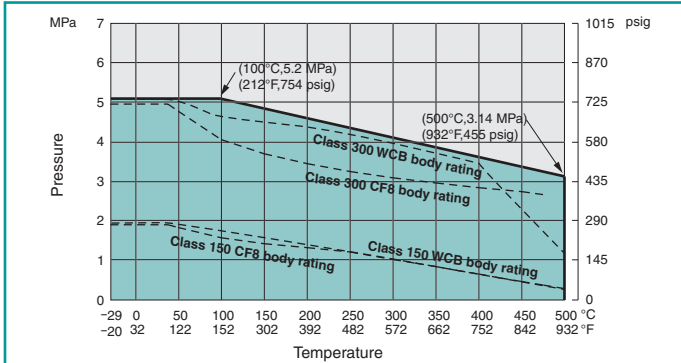

● Metal seated floating ball valves: Trim 6H: NPS 6, 8

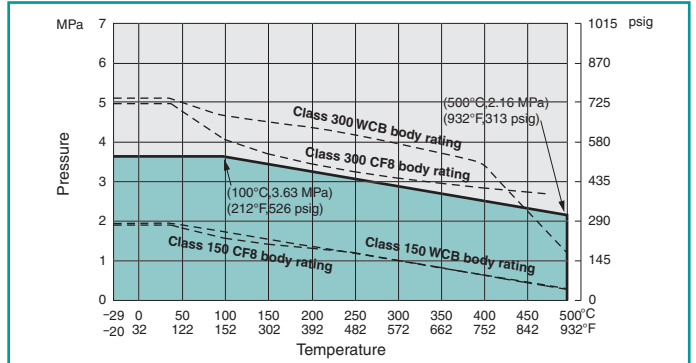

# Pressure-Temperature Ratings

**150UTB(M)/10/125FCTB(2L) : NPS 1/2, 3/4**  
**10/125FCTR(2L) : NPS 1/2 to 1**

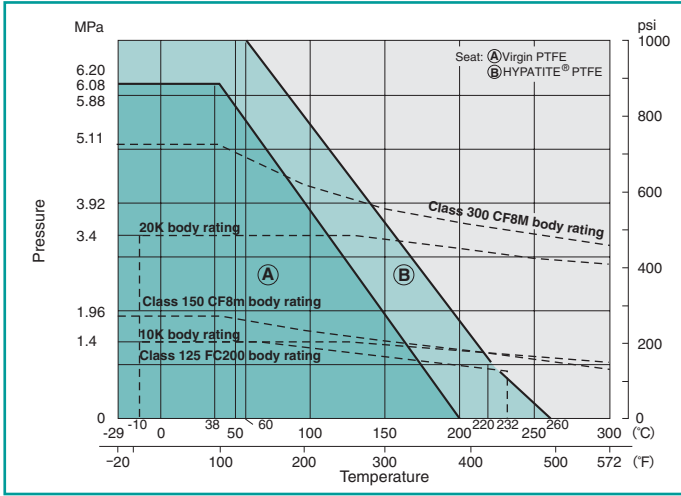

**150UTB(M)/10/125FCTB(2L) : NPS 1 to 2 1/2**  
**10/125FCTR(2L) : NPS 1 1/2 to 3**

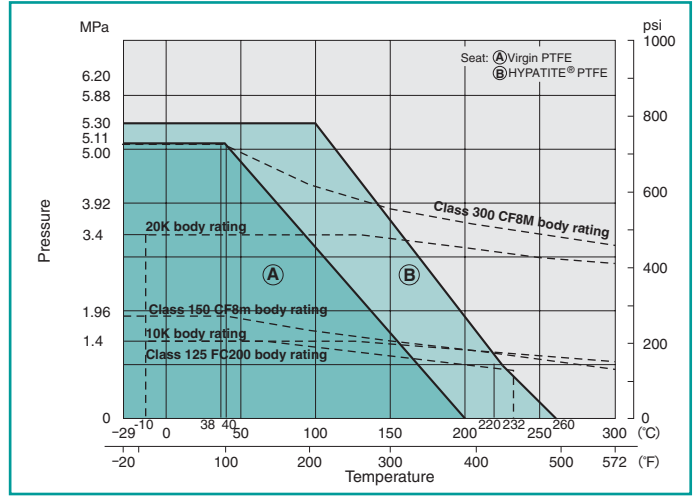

**150UTB(M)/10/125FCTB(2L) : NPS 3, 4**  
**10/125FCTR(2L) : NPS 4, 5**

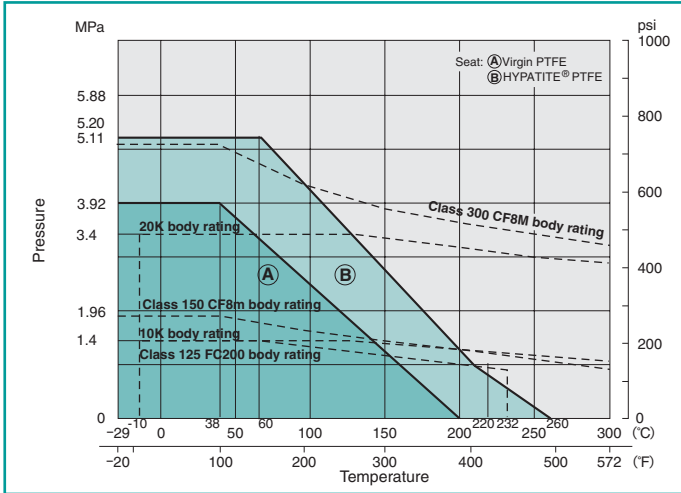

**150UTB(M)/10/125FCTB(2L) : NPS 5, 6**  
**10/125FCTR(2L) : NPS 6, 8**

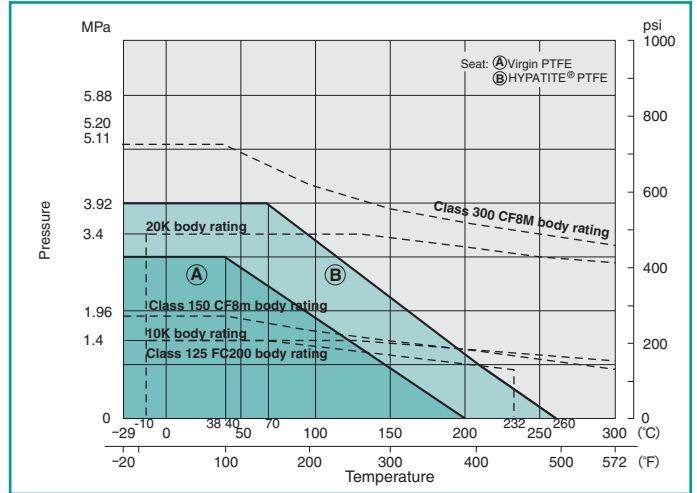

**150UTB(M)/10/125FCTB(2L) : NPS 8, 10**  
**10/125FCTR(2L) : NPS 10, 12**

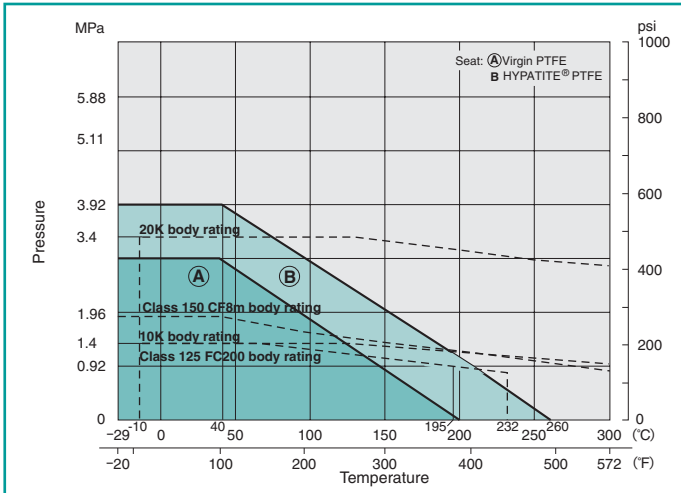

# Pressure-Temperature Ratings

## 600/1500SCTB/UTB(M)

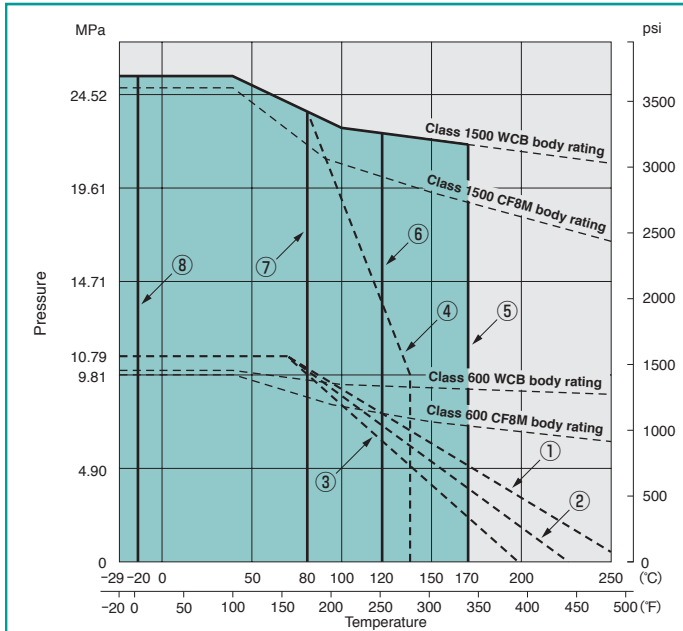

### Ball Seat Materials

- ①: KITZ HYPATITE® or Carbon-filled PTFE
- ②: Glass-filled PTFE with MoS<sub>2</sub>
- ③: Virgin PTFE
- ④: Nylon with MoS<sub>2</sub>

### O-ring Upper Limit

- ⑤: (1) FKM  
(2) Low-temperature FKM
- ⑥: (1) EPDM  
(2) ECO (Epichlorohydrin Copolymer)
- ⑦: (1) NBR  
(2) Low-temperature NBR

### O-ring Lower Limit

- ⑧: FKM
- \* O-rings made of others than FKM can with stand -29°C (-20°F)

## 3-way: 150UTB/TR4LA(M)/4TA(M)

\*Refer to 150UTBM ratings for 150UTB2LM/2TM

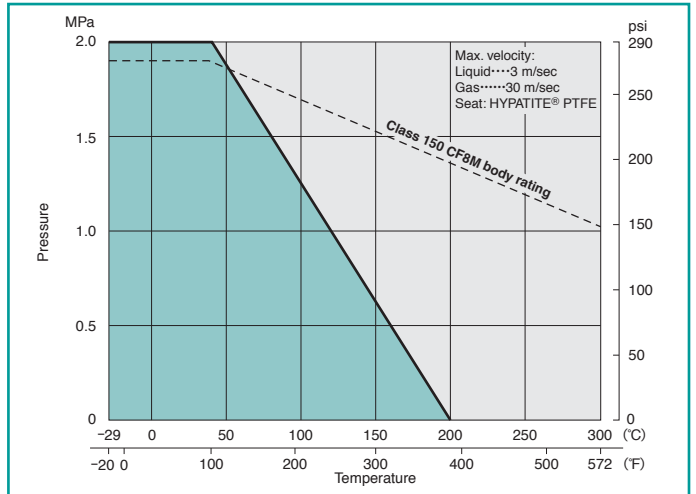

## PFA Lined: 150UTBLN

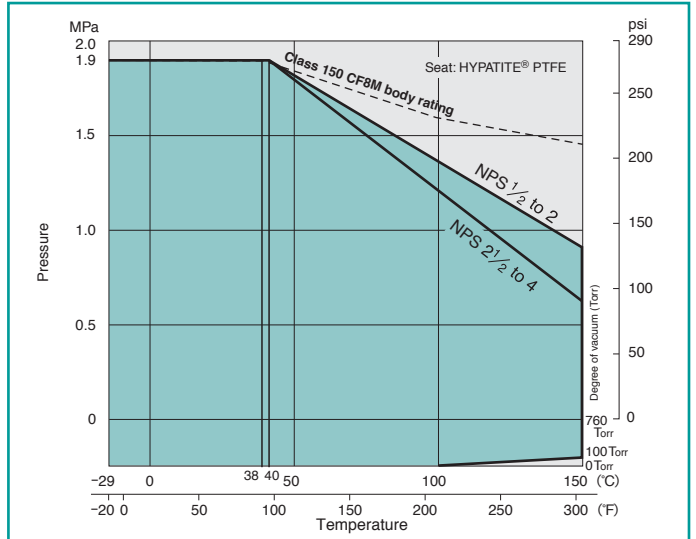

## 150/300UTDZXL(M)

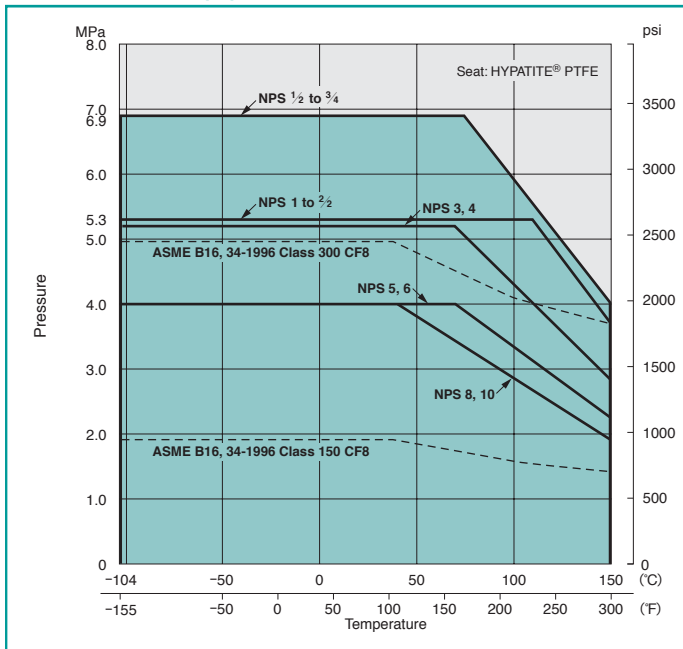

## Pressure-Temperature Ratings

### 150/300UVC(M) 60/20UVC(M)

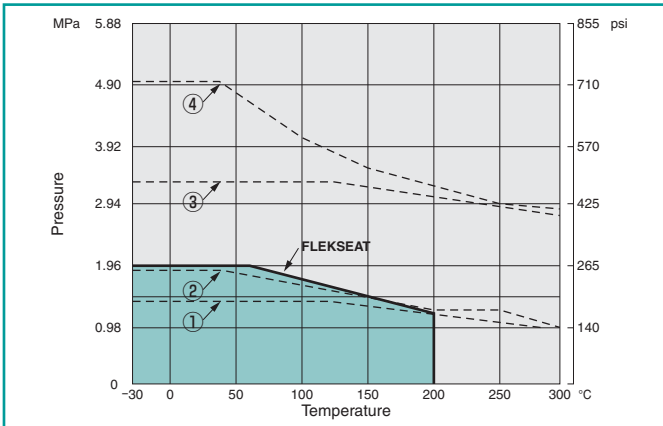

- ①: Valve body rating to JIS B2220 10K steel
- ②: Valve body rating to ASME B16.34 Class 150 CF8
- ③: Valve body rating to JIS B2220 20K steel
- ④: Valve body rating to ASME B16.34 Class 300 CF8

### 150/300UVCT(M) 10/20UVCT(M)

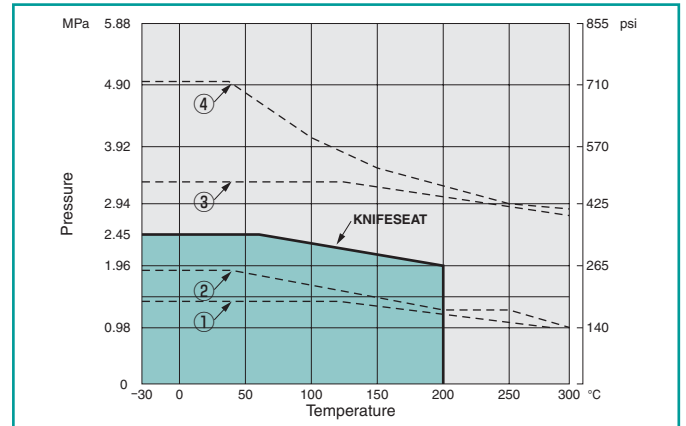

- ①: Valve body rating to JIS B2220 10K steel
- ②: Valve body rating to ASME B16.34 Class 150 CF8
- ③: Valve body rating to JIS B2220 20K steel
- ④: Valve body rating to ASME B16.34 Class 300 CF8

The products introduced in this catalog are all covered by the ISO 9001 Certification awarded KITZ Corporation in 1989, the earliest in the valve industry in Japan.

# Pressure-Temperature Ratings

**Type 600: SCTK/UTK(M)**

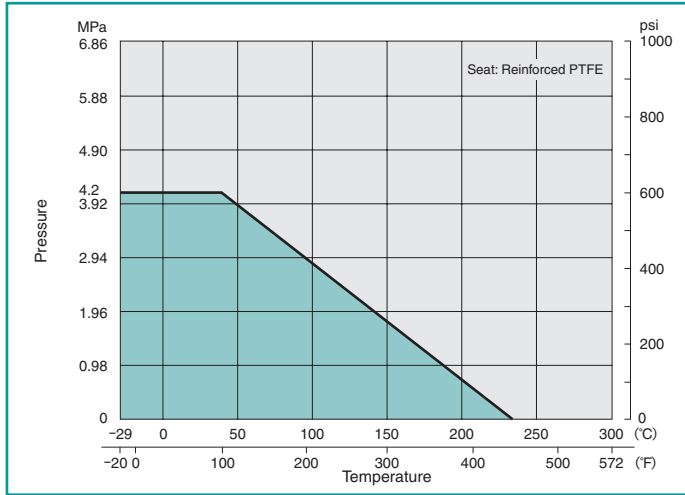

**Type 1000: UTFM**

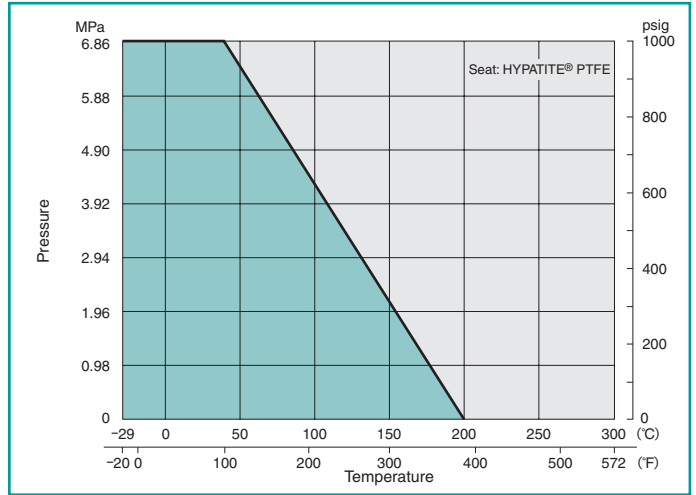

**Type 800: UTH(M)**

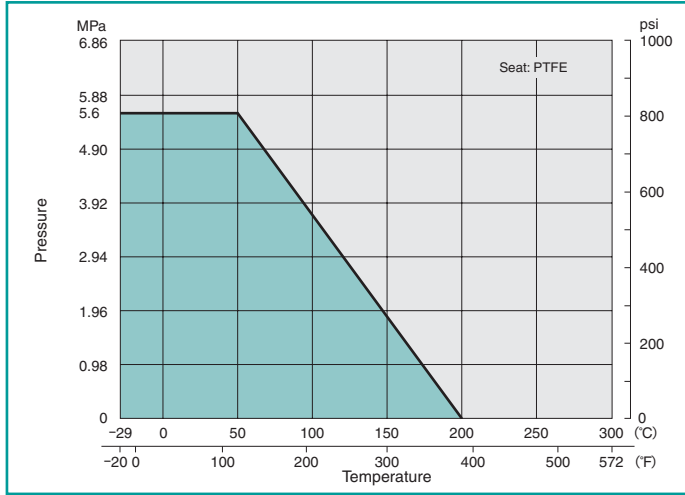

**Class 800 and Type 3000: SCTK**

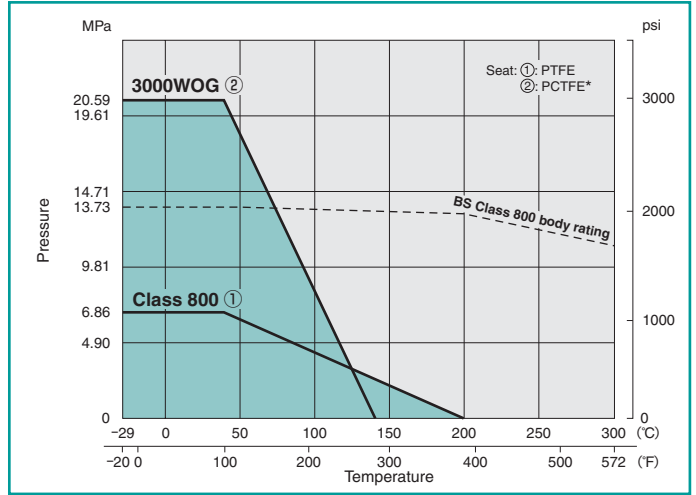

\* Polychloro-Trifluoro-Ethylene

**Type 800: UTH4LM/4TM**

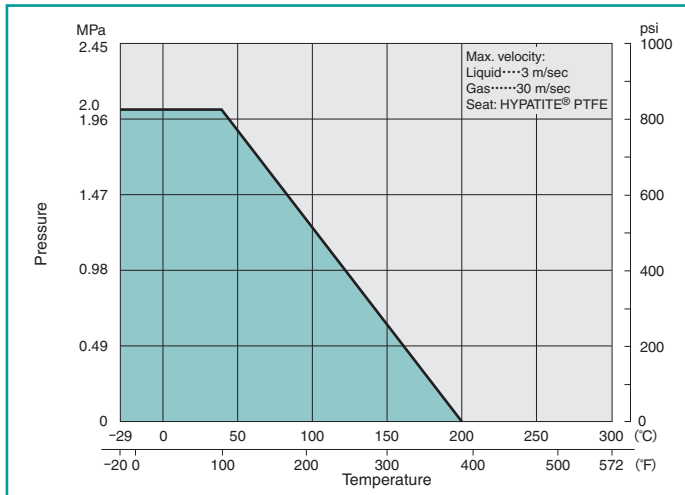

**Type 1000: SC3TZ/U3TZ Series**

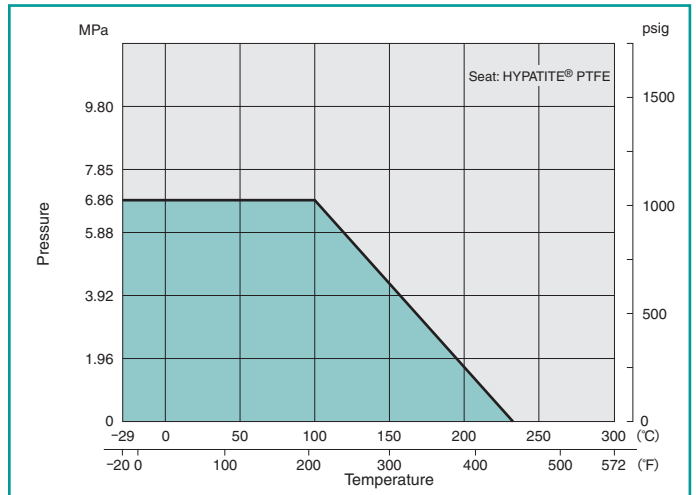

Note: Type 1500 is optionally available

## Pressure-Temperature Ratings

### Type 1500/2000: AKSCTHZM/AKSCTHWZM/AKUTHZM/AKUTHWZM

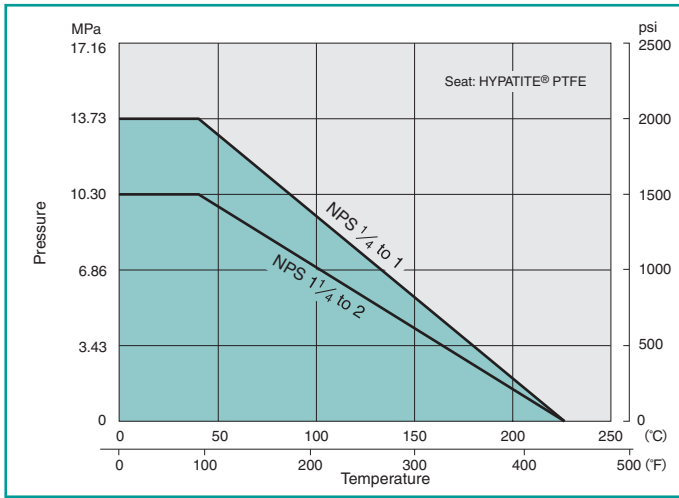

### Class 150: AK150UT(M)

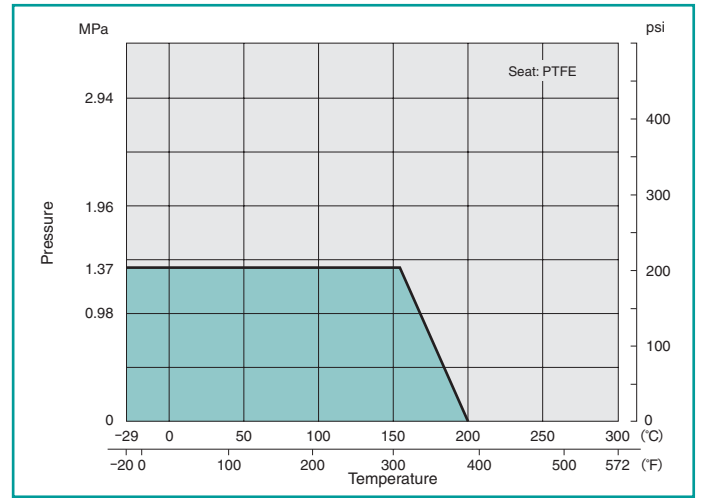

## Pressure-Temperature Ratings (Seat rating)

150/300UTAZL(M): NPS 1/2 to 2

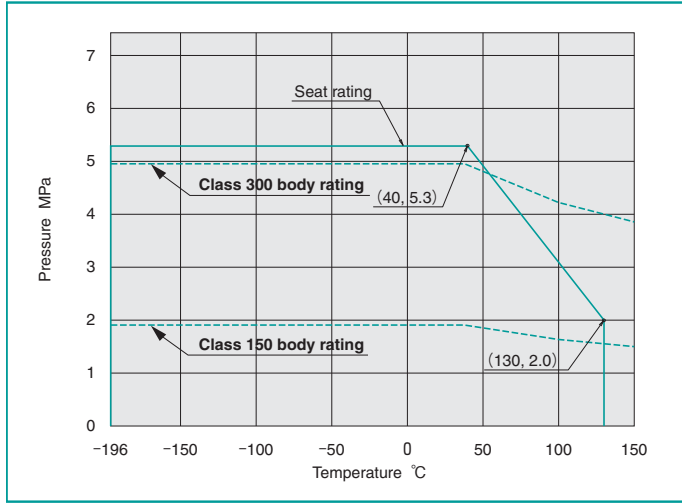

150/300UTAZL(M): NPS 3

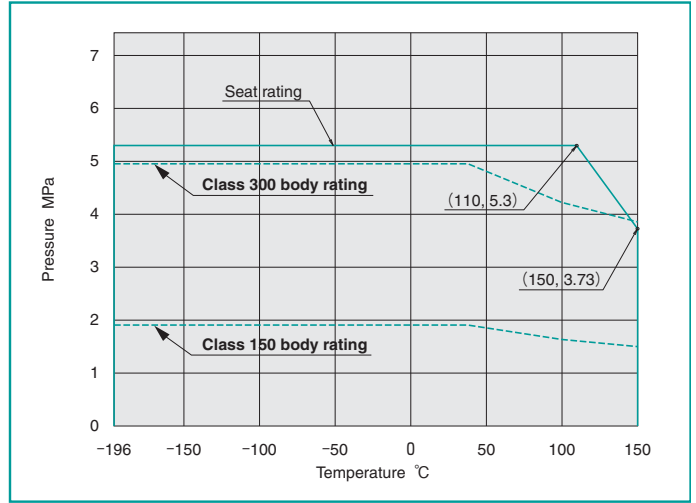

150/300UTAZL(M): NPS 4, 6

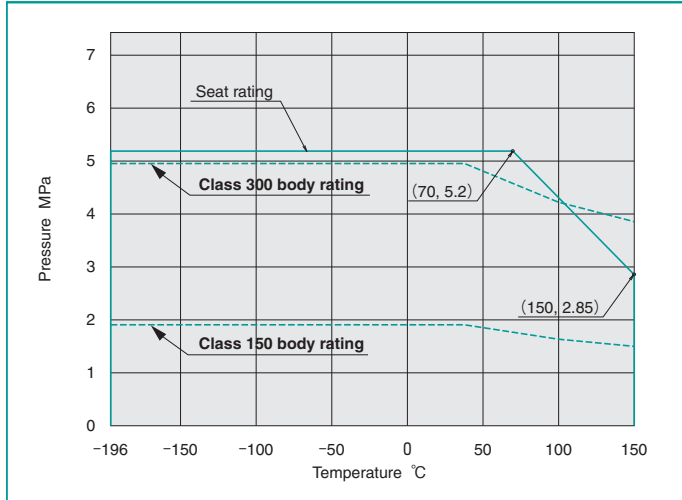

150/300UTAZL(M): NPS 8, 10

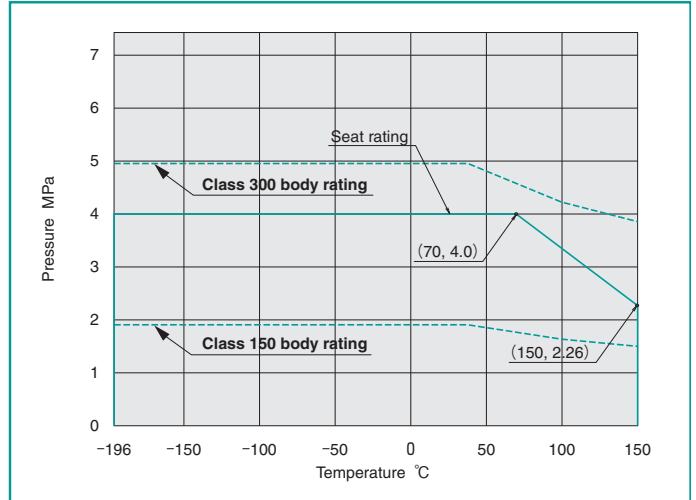

# Pressure-Temperature Ratings (Seat rating)

**150/300UTDZL(M): NPS 1½ to 1½**  
**10/20UTDZL(M): DN 15 to 40**

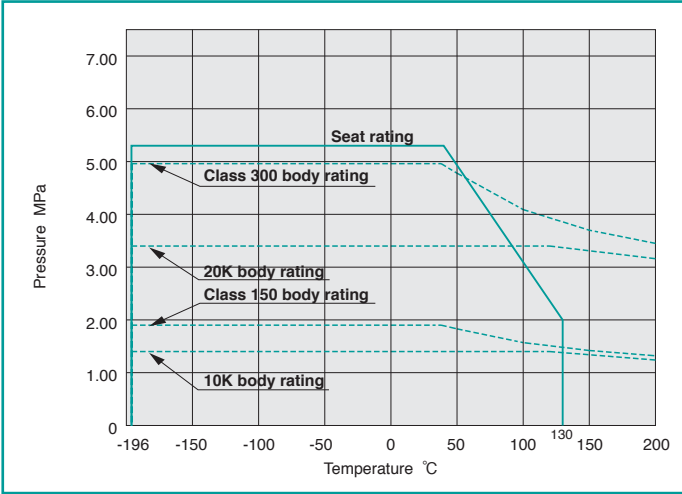

**150/300UTDZL(M): NPS 2, 2½**  
**10/20UTDZL(M): DN 50, 65**

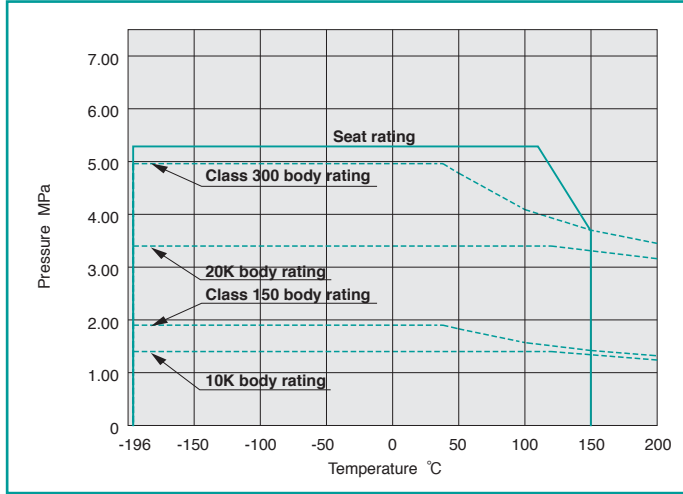

**150/300UTDZL(M): NPS 3, 4**  
**10/20UTDZL(M): DN 80, 100**

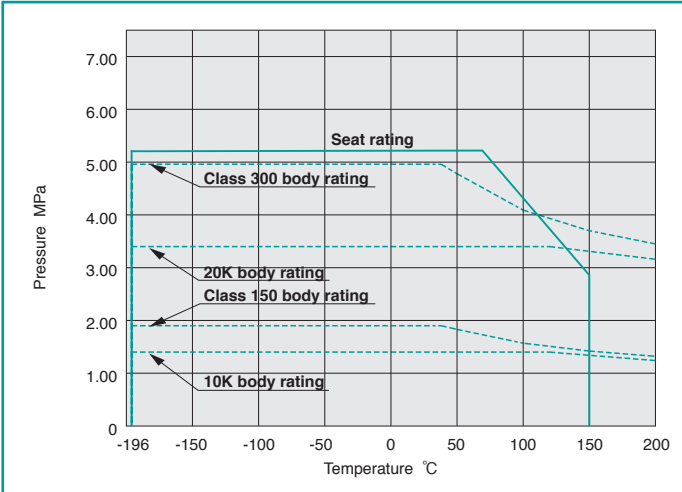

**150/300UTDZL(M): NPS 5, 6**  
**10/20UTDZL(M): DN 125, 150**

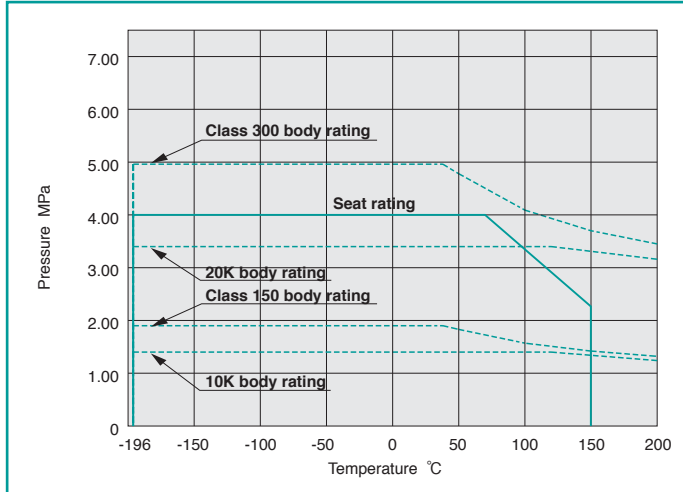

**150/300UTDZL(M): NPS 8, 10**  
**10/20UTDZL(M): DN 200, 250**

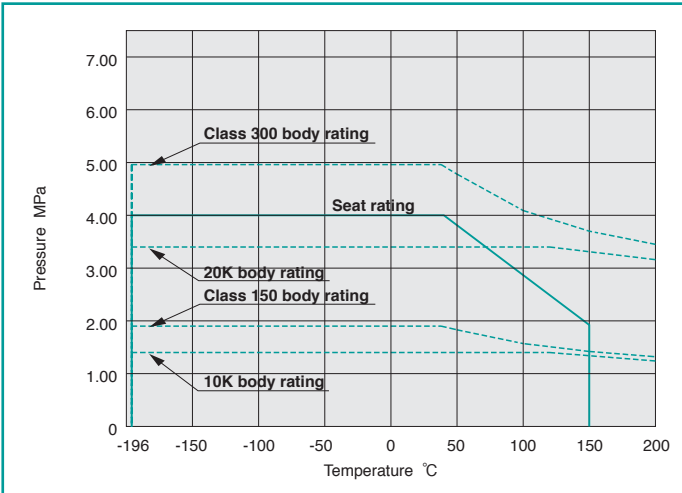



## Allowable Port Orientation

Valve Design	Form	Fluid Passage
3-Way 2-Seat L-port ball valve	<p>Top View</p> <p>Form 1      Form 2</p>	<ol style="list-style-type: none"> <li>Flow in Form 1 is between Ports "A" and "C". Flow in Form 2 is between Ports "B" and "C". The flow paths in Form 1 and Form 2 can be exchanged.</li> <li>When the fluid pressure P2 in the closed path is higher than P1 in the open path, slight fluid leakage may occur to P1 through the ball seat of the closed path.</li> </ol>
3-Way 4-Seat L-port ball valve	<p>Top View</p> <p>Form 1      Form 2</p>	<ol style="list-style-type: none"> <li>Flow in Form 1 is between Ports "A" and "C". Flow in Form 2 is between Ports "B" and "C". The flow paths in Form 1 and Form 2 can be exchanged.</li> <li>When the fluid pressure P2 in the closed path is higher than P1 in the open path, slight fluid leakage may occur to P1 through the ball seat of the closed path.</li> </ol>
3-Way 2-Seat T-port ball valve	<p>Top View</p> <p>Form 1      Form 2 Form 3      Form 4 Not Available</p>	<ol style="list-style-type: none"> <li>In Form 1, all ports are open. Flow in Form 2 is between Ports "B" and "C". Flow in Form 4 is between Ports "A" and "C". Flow can be switched from Form 1 to Form 2, (standard operation pattern) or from Form 1 to Form 4 in either direction. The stopper is assembled for the standard operation pattern.</li> <li>When the fluid pressure P2 in the closed path is higher than P1 in the open path, slight fluid leakage may occur to P1 through the ball seat of the closed path.</li> </ol> <p>■ Available operation patterns</p> <ul style="list-style-type: none"> <li>• Pattern 1: From Form 1 to Form 4</li> <li>• Pattern 2: From Form 1 to Form 2 (Standard)</li> </ul> <p>Please select one of the above operation patterns at the time of order.</p>
3-Way 4-Seat T-port ball valve	<p>Top View</p> <p>Form 1      Form 2 Form 3      Form 4</p>	<ol style="list-style-type: none"> <li>In Form 1, all ports are open. Flow in Form 2 is between Ports "B" and "C". Flow in Form 3 is between Ports "A" and "B". Flow in Form 4 is between Ports "A" and "C". All forms are available for switching, diverging, or mixing of flows. The stopper is assembled for a standard operation pattern to switch flow from Form 1 to Form 2.</li> <li>When the fluid pressure P2 in the closed path is higher than P1 in the open path, slight fluid leakage may occur to P1 through the ball seat of the closed path.</li> </ol> <p>■ Available operation patterns</p> <ul style="list-style-type: none"> <li>• Pattern 1: From Form 1 to Form 4</li> <li>• Pattern 2: From Form 1 to Form 2 (Standard)</li> <li>• Pattern 3: From Form 3 to Form 4</li> <li>• Pattern 4: From Form 2 to Form 3</li> </ul> <p>Please select one of the above operation patterns at the time of order.</p>

## General Precautions for Trouble-free Operation of Soft-seated Ball Valves

### 1. Excessive Cavity Pressure

*Refer to Page 8. Very important*

### 2. High-Temperature and High-Pressure Service

The pressure-temperature ratings published by manufacturers are usually considered an appropriate guide to the maximum temperature and pressure that such ball valves may withstand. KITZ recommends, however, reference to the valve distributor or manufacturer for an assurance of suitability when ball valves are to be subjected to the following conditions:

- a: **Floating ball valves** are left closed for a long period of time under high temperature or high differential pressure.
- b: **Floating ball valves** are operated frequently for long period of time under high temperature or high differential pressure.
- c: **Floating ball valves** are subjected to frequent change of the line pressure or service temperature.

### 3. Liquids with High Velocity

When ball valves must be operated frequently on liquids with very high velocity, a check should be made with the valve distributor or manufacturer for appropriate advice to minimize the possibility of seat deformation, especially when they are highly pressurized on high-temperature lines.

### 4. Valve Selection

Be sure to select a valve with design specifications which meet the pressure and temperature conditions required. Take special care to select the valve to be used for the fluid containing abrasives, since the high molecular materials employed in the seats could suffer degradation.

### 5. Valve Mounting

Before mounting the valve, the pipe bore should be checked to confirm that no weld spatter, scale or rust particles remain inside. For mounting flanged valves, diagonally located flange bolts should be tightened evenly.

### 6. Degree of Valve Opening

Ball valves should basically be considered as ON/OFF valves only and care should be taken to ensure that they are fully closed or open. Opening ball valves partially will result in seat erosion and cause seat leakage. Pipelines that require the use of ball valves for throttling service should be designed in consideration of the amount of the seat leakage which may occur in its fully closed position. Note that ball valves should be stored in a fully open position.

### 7. Valve Actuation

Two types of pneumatic valve actuator (KITZ B-Series, F-Series) are available for our factory mounting. Also KITZ "KELMO" electric actuators are available. Electric actuators or pneumatic actuators of any other specified brands are also available for our factory mounting.

In case of user's mounting their own actuators on KITZ ball valves, however, all users are recommended to contact KITZ or its authorized distributors for adequate technical advice, because any improper sizing of actuators may cause serious problems in the field. It must be carefully noted that the actual value of the operating torque of any given valve may vary, depending on the service conditions listed below:

- (1) Fluid
  - a. Kind of fluid
  - b. Line pressure
  - c. Line temperature
  - d. Fluid volume
- (2) Ambient temperature
- (3) Opening/closing degree
- (4) Type of actuator
- (5) Frequency and pattern of change of line pressure
- (6) Frequency and pattern of change of line and ambient temperatures

### 8. Valve Disassembly

The line fluid should be completely removed from the internal of the valves before they are dismantled from the pipeline for maintenance.

Even after the line fluid has been discharged through the pipeline, some fluid is always trapped inside the body and body cavity (the space surrounded by the body, ball and two seats).

Be sure to completely discharge the pressure trapped in the body cavity, before valve disassembly.

### Inspection and Warranty

Each KITZ ball valve is subjected to 100% in-house inspection designated by API 598 or BS 6755 Part 1. This includes hydrostatic shell tests and pneumatic low-pressure seat test. Manufacturer's material certificates and test reports are available upon request. Each KITZ ball valve is guaranteed for 12 months after placement in service, but not exceeding 18 months after shipment from KITZ factories.

## Flow Characteristics

One of the best advantages of ball valves is that every flow per any given bore size is larger than other types of valves. Fluid is much less disturbed by eddy currents or pulsation. To obtain the figure of flow per valve opening, simply multiply the flow rate (%) given here by the corresponding value given in the table of Pressure Loss vs. Flow Rate.

Valve opening vs. Cv

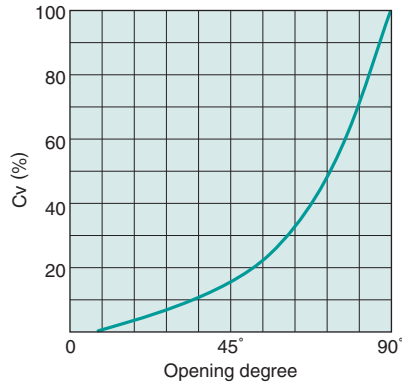

## Pressure Loss vs. Flow Rate

### Full port valves

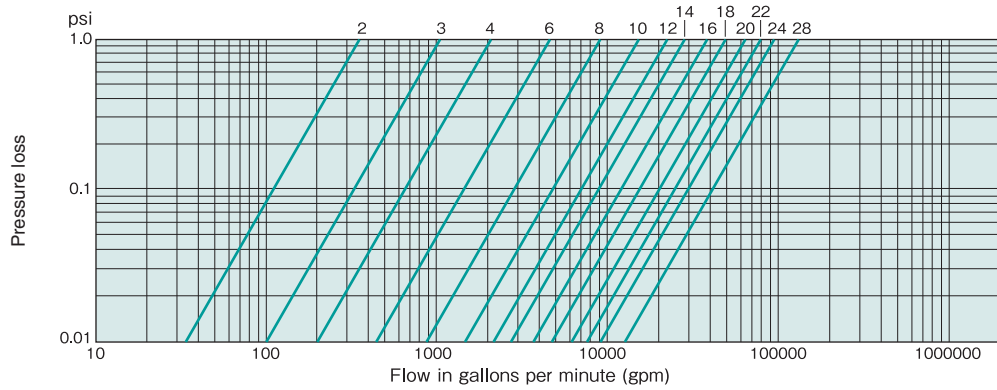

### Reduced port valves

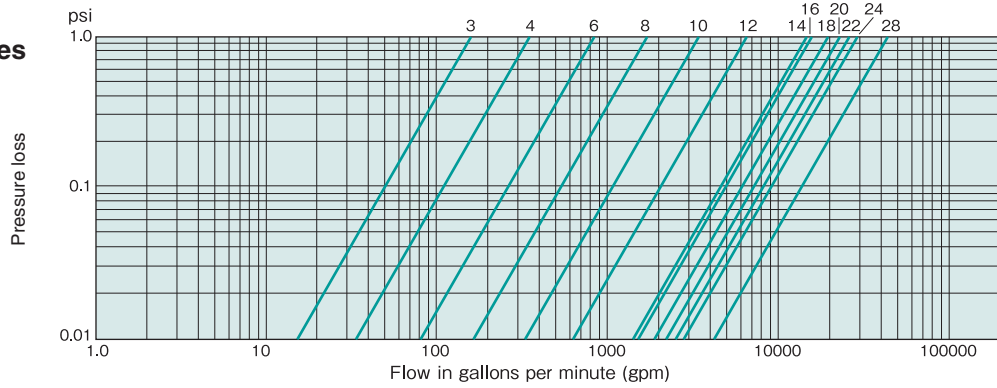

### Schedule 40 steel pipe (10m)

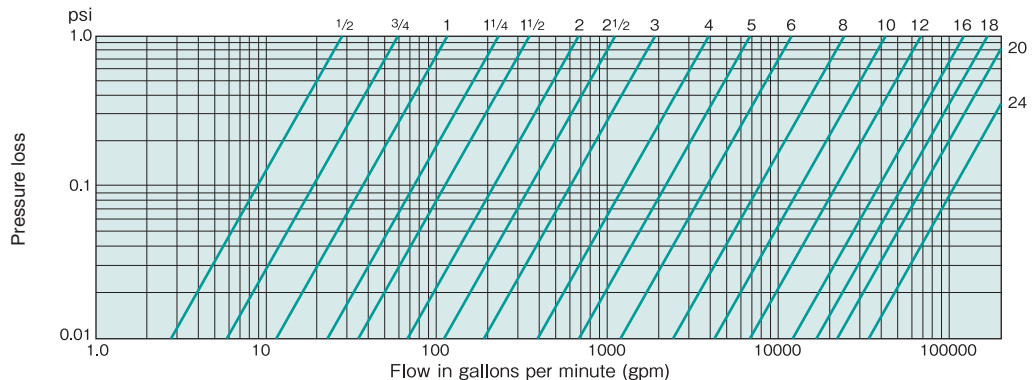



## CAUTION

Pressure-temperature ratings and other performance data published in this catalog have been developed from our design calculation, in-house testing, field reports provided by our customers and/or published official standards or specifications. They are good only to cover typical applications as a general guideline to users of KITZ products introduced in this catalog.

For any specific application, users are kindly requested to contact KITZ Corporation for technical advice, or to carry out their own study and evaluation for proving the suitability of these products to such an application. Failure to follow this request could result in property damage and/or personal injury, for which we shall not be liable.

While this catalog has been compiled with the utmost care, we assume no responsibility for errors, impropriety, or inadequacy. Any information provided in this catalog is subject to from-time-to-time change without notice for error rectification, product discontinuation, design modification, new product introduction or any other cause that KITZ Corporation considers necessary. This edition cancels all previous issues.

Read the instruction manual carefully before use.

## NOTICE

If any products designated as strategic material in the Foreign Exchange and Foreign Trade Law, Cabinet Order Concerning Control of Export Trade, Cabinet Order Concerning Control of Foreign Exchange and other related laws and ordinances ("Foreign Exchange Laws") are exported to any foreign country or countries, an export license issued by the Japanese Government will be required under the Foreign Exchange Laws.

Further, there may be cases where an export license issued by the government of the United States or other country will be required under the applicable export-related laws and ordinances in such relevant countries.

The contract shall become effective subject to the fact that a relevant export license is obtained from the Japanese Government.

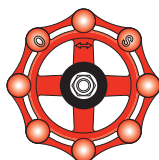

*A chrysanthemum-handle is a symbol of KITZ,  
the brand of value reliability*

ISO 9001 certified since 1989

**KITZ**  
KITZ CORPORATION

1-10-1 Nakase, Mihama-ku, Chiba 261-8577, Japan  
International Sales Dept.  
Phone : 81-43-299-1730  
Fax : 81-43-299-0121

— Distributed by —

