

CAST IRON KNIFE GATE VALVE FLANGED END 10K

50mm - 300mm

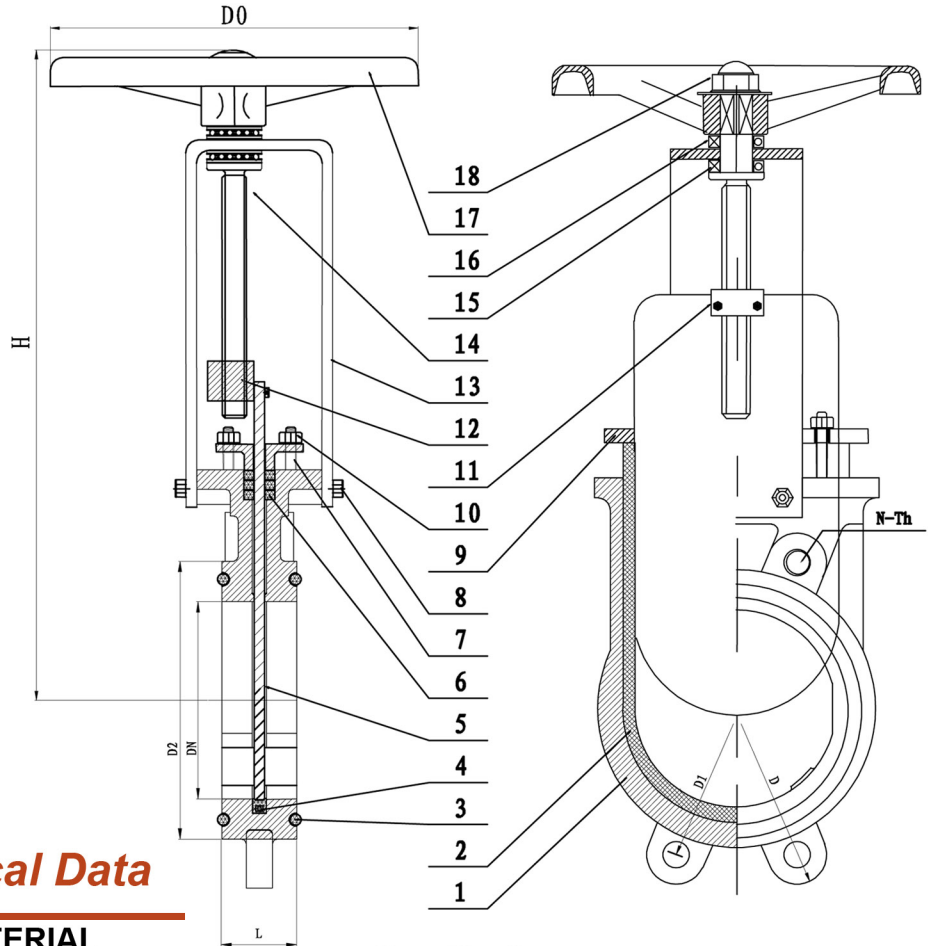
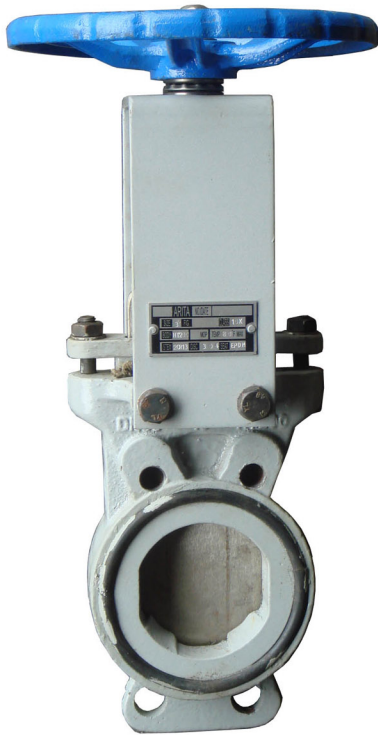

Technical Data

Material

No.	PART	MATERIAL
1	BODY	CAST IRON
2	SEALING	EPDM
3	SEAT RING	EPDM
4	ROUND RUBBER	EPDM
5	STEEL WIRE	304
6	DISC	Flexible Graphite
7	PACKING	A3
8	CONNECT	A3
9	CONNECT	WCB
10	GLAND	A3
11	NUT	A3
12	CONNECT	QT500
13	NUT	A3
14	BRACKET	2Cr13
15	BEARING	zchsnsb10-6
16	BEARING	zchsnsb10-6
17	HANDWHEEL	QT250
18	CAP NUT	A3

Specification :

Nominal Pressure : 10 K
 Strength Test : 1.5 Mpa
 Testing Pressure : 1.1 Mpa
 Max. Temperature : 100 deg C

Dimension in mm

SIZES		L	D	D1	D2	D0	N-Th	H
DN	in.							
50	2"	48	160	125	100	200	4-M16	309
65	2.1/2"	48	175	140	120	200	4-M16	347
80	3"	51	185	150	130	200	8-M16	369
100	4"	51	210	175	155	240	8-M16	413
125	5"	57	250	210	185	240	8-M20	475
150	6"	57	280	240	215	280	8-M20	529
200	8"	70	330	290	265	280	12-M20	695
250	10"	70	400	355	325	320	12-M22	753
300	12"	76	445	400	370	320	16-M22	885

The contents of this literature are for informative purposes only. Arita is not responsible for suitability or compatibility of these products in relation to system requirement. For specific requirements, consult Arita or its distributors. Arita reserves the right to change or modify product design without prior notice.

CAST IRON KNIFE GATE VALVE FLANGED END 10K

350mm - 450mm

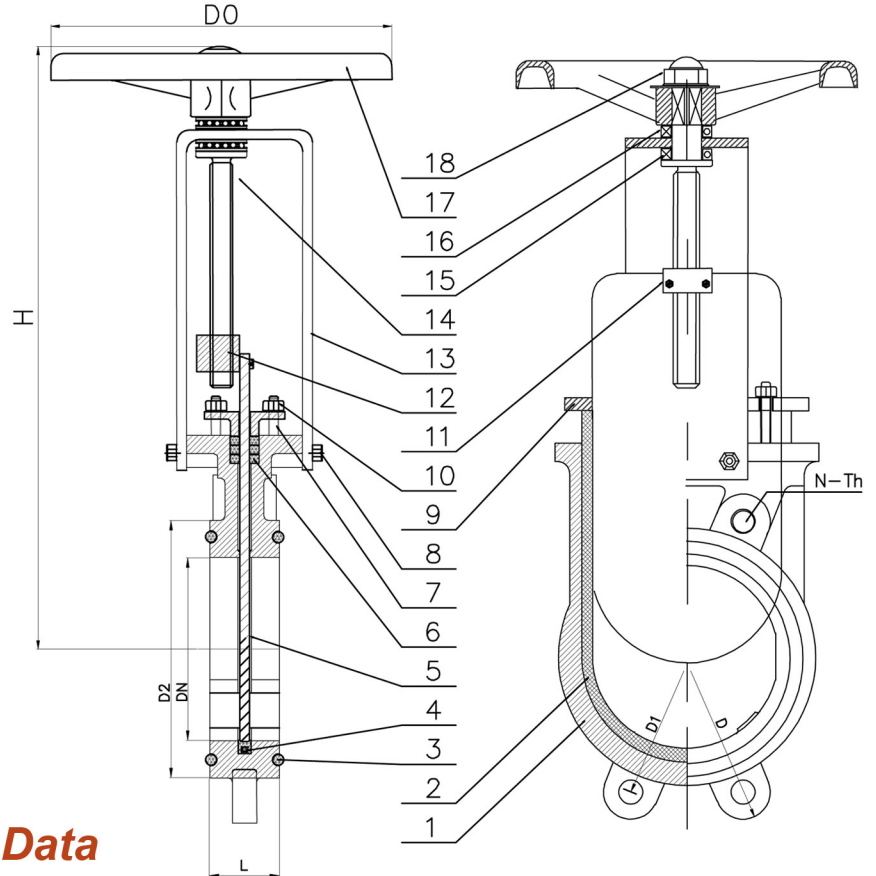

Technical Data

Material

No.	PART	MATERIAL
1	BODY	CAST IRON
2	SEALING STRIP	EPDM
3	SEALING STRIP	EPDM
4	WIRE	EPDM
5	DISC	304
6	PACKING	PTFE
7	STUD BOLT	A3
8	SINGLE HEAD SCREW	A3
9	BONNET	WCB
10	NUT	A3
11	SINGLE HEAD SCREW	A3
12	YOKE NUT	QT500
13	YOKE	A3
14	STEM	2Cr13
15	BEARING	zchsnsb10-6
16	BEARING	zchsnsb10-6
17	HANDWHEEL	QT250
18	CAP NUT	A3

Specification :

Nominal Pressure : 10 K
 Strength Test : 1.5 Mpa
 Testing Pressure : 1.1 Mpa
 Max. Temperature : 100 deg C

Dimension in mm

SIZES		L	D	D1	D2	D0	N-Th	H
DN	in.							
350	14"	76	490	445	415	-	16-M22	-
400	16"	89	560	510	475	-	16-M22	-
450	18"	89	620	565	530	-	20-M24	-