

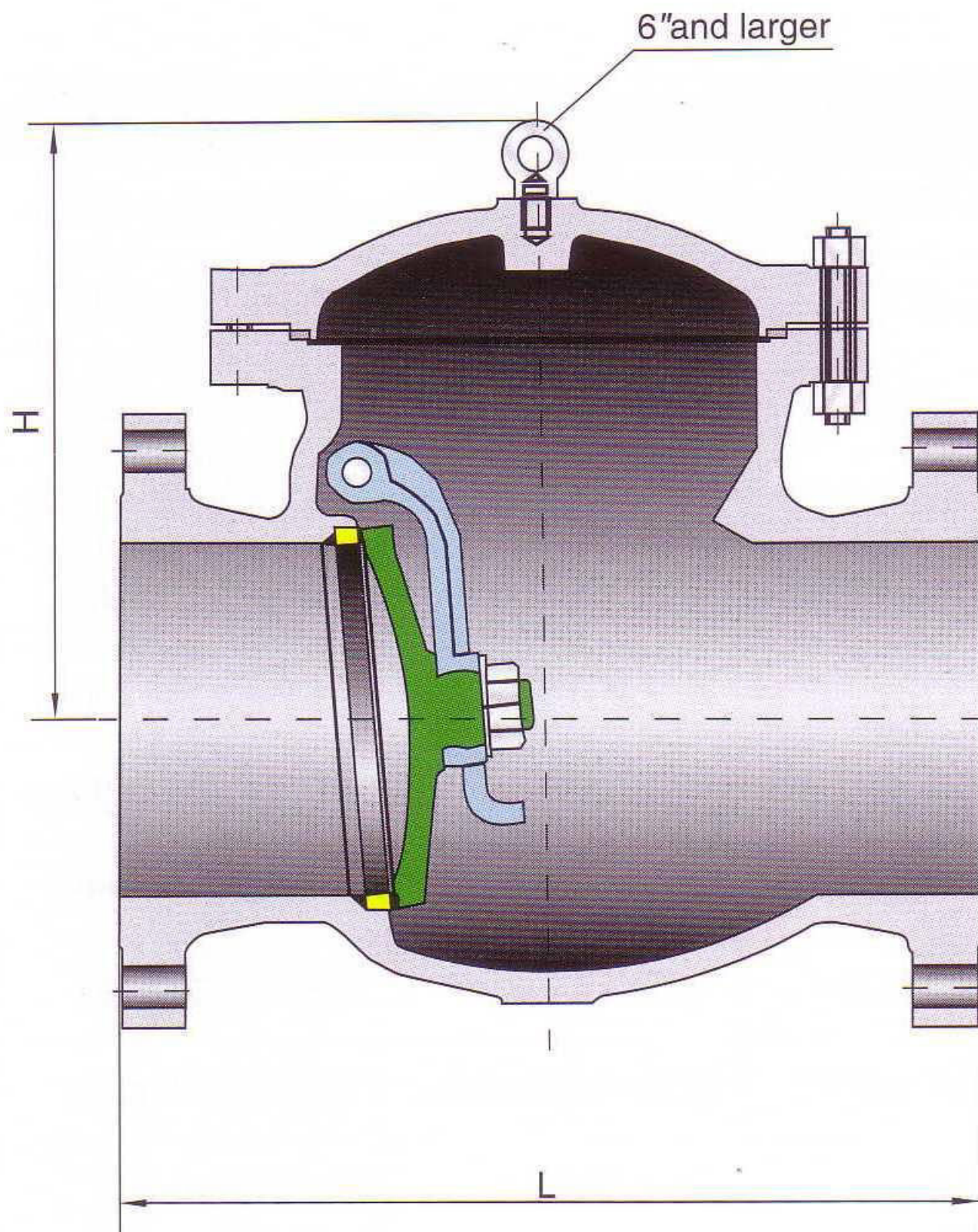

Cast Steel Bolted Cover Check Valves

Class 300

Bolted Cover, Swing Type Disc.



Parts List

PART	MATERIALS		
	ASTM A216 WCB	ASTM A351 CF8	ASTM A351 CF8M
Body	ASTM A216 WCB	ASTM A351 CF8	ASTM A351 CF8M
Seat ring	A105+STL	ASTM A351 CF8	ASTM A351 CF8M
Disc	WCB+13Cr	ASTM A351 CF8	ASTM A351 CF8M
Hinge	ASTM A216 WCB	ASTM A351 CF8	ASTM A351 CF8M
Nut	ASTM A194 2H	ASTM A194 8	ASTM A194 8M
Hinge pin	ASTM A182 F6a	ASTM A182 F304	ASTM A182 F316
Bonnet	ASTM A216 WCB	ASTM A351 CF8	ASTM A351 CF8M
Bonnet bolt	ASTM A193 B7	ASTM A193 B8	ASTM A193 B8M
Bonnet nut	ASTM A194 2H	ASTM A194 8	ASTM A194 8M
Gasket	SS304+Graphite	SS304+Graphite	SS316+Graphite
Eye bolt	Cast Steel	Cast Steel	Cast Steel

Features

- Face to face and end to end dimension: ASME B16.10
- Flange dimension:
24" and smaller valves: ASME B16.5
28" and larger valves: ASME B 16.47 series A
- Shell wall thickness:
24" and smaller to API 600
28" and larger to manufacturer's standard
- B.W. End to ASME B 16.25

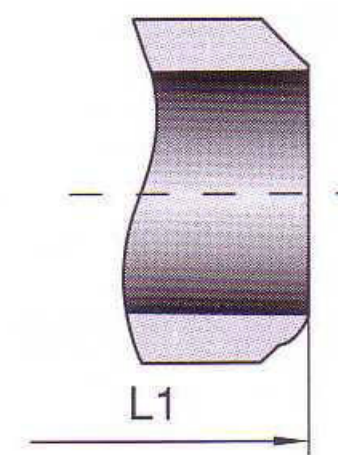
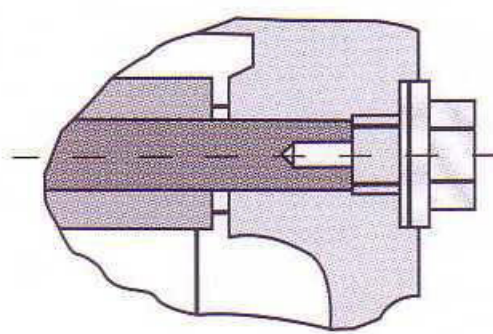

BW End

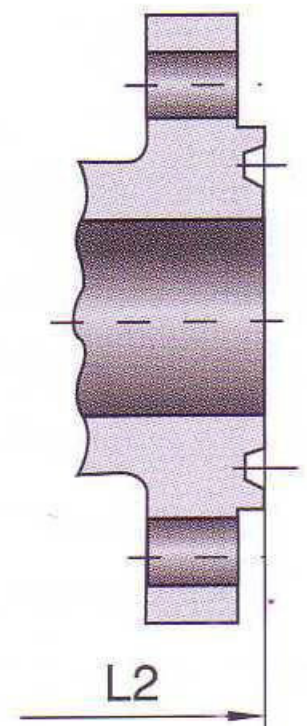

RTJ End

Dimensions And Weights

Valve Size	in.	1 1/2	2	2 1/2	3	4	5	6	8	10	12	14	16	18	20	24	30	36
	mm	40	50	65	80	100	125	150	200	250	300	350	400	450	500	600	750	900
L-L1 (RF-BW)	in.	9.5	10.5	11.5	12.5	14	15.75	17.5	21	24.5	28	33	34	38.5	40	53	62.75	82
	mm	241	267	292	318	356	400	444	533	622	711	838	864	978	1016	1346	1594	2083
L2 (RTJ)	in.	10	11.12	12.12	13.15	14.62	16.37	18.12	21.62	25.12	28.62	33.62	34.62	39.12	40.75	53.88	63.75	83.11
	mm	254	283	308	334	371	416	460	549	638	727	854	879	994	1035	1369	1619	2111
H (open)	in.	7.4	7.75	8	8.75	10.88	11.63	13.25	16.25	18.25	22.13	23.5	25.38	29.88	33.63	37	50	60.63
	mm	188	197	203	222	276	295	337	413	464	562	597	645	759	854	940	1270	1540
WT (kg)	RF	31	35	37	60	82	110	155	268	380	495	710	950	1200	1350	2200	3400	5000
	BW	28	32	35	50	65	70	128	230	270	460	555	800	970	1070	1780	2950	4300