

## Stainless Steel 304 / 316 Knife Gate Valve Flange End JIS 10K

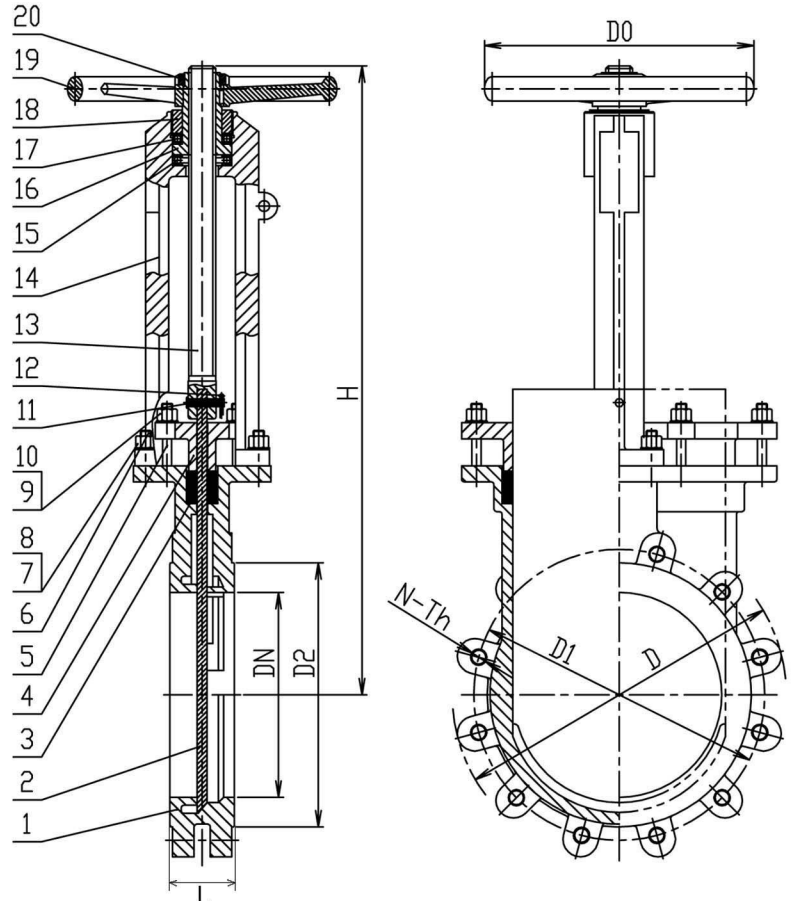
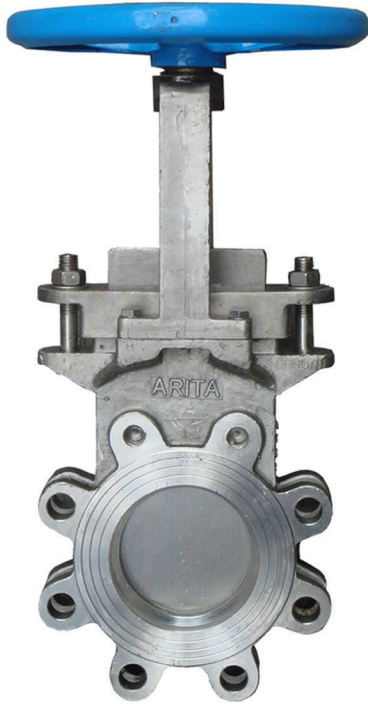

### Specification :

Nominal Pressure : 10K  
 Strength Test : 1.5 Mpa  
 Testing Pressure : 1.1 Mpa  
 Max. Temperature : 230 deg C  
 Applicable Media : Pulp and Paper, Sewage,  
 Chemical, Mining and etc.

### Technical Requirement :

Design and Made : JB/T8691-1998  
 Pressure Test : GB/T13927-92  
 Face to Face : GB/T1518.2-94  
 Flange : GB/T9113.1-2000, JB/T79-94

### Dimension (mm)

Size	L	D	D1	D2	D0	N-Th	H
50	48	155	120	100	200	4-M16	309
65	48	175	140	120	200	4-M16	347
80	51	185	150	130	200	8-M16	369
100	51	210	175	155	240	8-M16	413
125	57	250	210	185	240	8-M20	475
150	57	280	240	215	280	8-M20	529
200	70	330	290	265	280	12-M20	695
250	70	400	355	325	320	12-M22	753
300	76	445	400	370	320	16-M22	885

### Material

No.	Part Name	Material
1	Body	SS304 SS316
2	Disc	SS304 SS316
3	Packing	Flexible Graphite
4	Gland	SS304 SS316
5	Screw Bolt	SS201 SS304
6	Screw Bolt	SS201 SS304
7	Nut	SS201 SS304
8	Washer	SS201 SS304
9	Nut	SS201 SS304
10	Washer	SS201 SS304
11	Connecting Pin	SS201 SS304
12	Split Pin	SS201 SS304
13	Stem	SS304
14	Yoke	SS304
15	Bearing	Steel Alloy
16	Nut	Brass
17	Bearing	Steel Alloy
18	Cap Nut	Bronze Alloy
19	Handwheel	Cast Ductile
20	Cap Nut	SS400