

## Stainless Steel 304 / 316 Knife Gate Valve Flange End 150 LBS

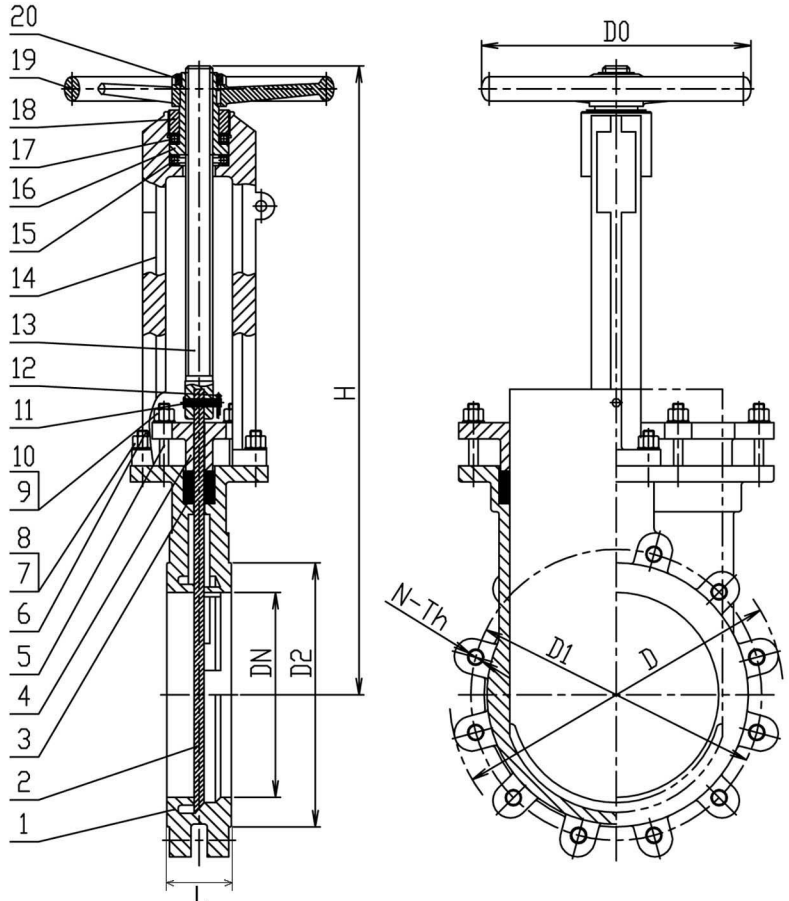
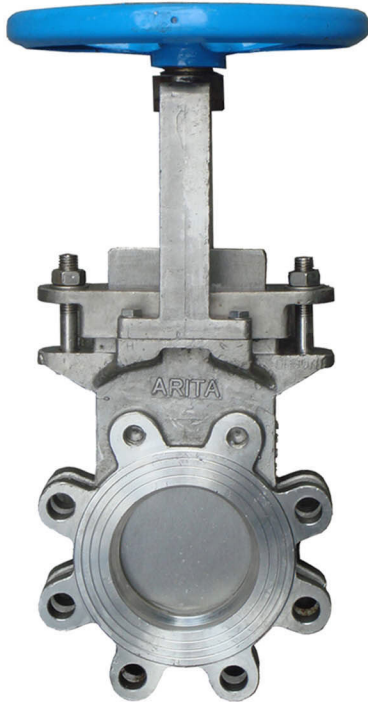

### Specification :

Nominal Pressure : 150 LB  
 Strength Test : 3.0 Mpa  
 Testing Pressure : 2.2 Mpa  
 Max. Temperature : 230 deg C  
 Applicable Media : Pulp and Paper, Sewage,  
 Chemical, Mining and etc.

### Technical Requirement :

Design and Made : JB/T8691-1998  
 Pressure Test : GB/T13927-92  
 Face to Face : GB/T1518.2-94  
 Flange : GB/T9113.1-2000, JB/T79-94

### Dimension (mm)

Size	L	D	D1	D2	D0	N-Th	H
50	48	155	120	92	200	4-5/8-11	309
65	48	178	139.5	105	200	4-5/8-11	347
80	51	190.5	152.5	127	200	4-5/8-11	369
100	51	220.5	190.5	157	240	8-5/8-11	413
125	57	254	216	186	240	8-3/4-10	475
150	57	279	241.5	216	280	8-3/4-10	529
200	70	343	298.5	270	280	8-3/4-10	695
250	70	406	362	324	320	12-m7/8-9	753
300	76	483	432	381	320	12-m7/8-9	885

### Material

No.	Part Name	Material
1	Body	SS304 SS316
2	Disc	SS304 SS316
3	Packing	Flexible Graphite
4	Gland	SS304 SS316
5	Screw Bolt	SS201 SS304
6	Screw Bolt	SS201 SS304
7	Nut	SS201 SS304
8	Washer	SS201 SS304
9	Nut	SS201 SS304
10	Washer	SS201 SS304
11	Connecting Pin	SS201 SS304
12	Split Pin	SS201 SS304
13	Stem	SS304
14	Yoke	SS304
15	Bearing	Steel Alloy
16	Nut	Brass
17	Bearing	Steel Alloy
18	Cap Nut	Bronze Alloy
19	Handwheel	Cast Ductile
20	Cap Nut	SS400