

ARITA STAINLESS STEEL BALL VALVE

REDUCE PORT 1-PC BODY BALL VALVE 1000 W.O.G. (BSPT)

ARV-100SE-1PC

SPECIFICATIONS

- Screwed end : BSPT (optional NPT)
- Design Standard : ASME B16.34
- Blow out proof design
- Inspection and Test : API 598
- Applicable Media : W.O.G.
- Applicable Temperature : -29 ~ 180 °C

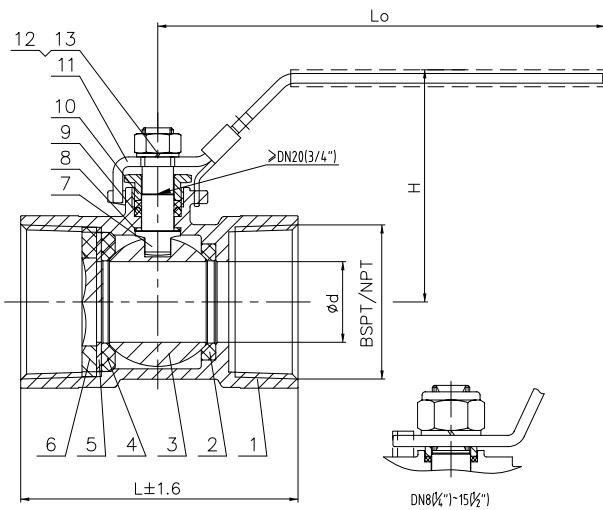

STANDARD COMPONENT MATERIAL

NO	DESCRIPTION	QTY.	MATERIAL
1	Body	1	SS 304 / SS 316
2	Seat Ring 1	1	RPTFE
3	Ball	1	SS 304 / SS 316
4	Seat Ring 2	1	RPTFE
5	Gasket	1	SS 304 / SS 316
6	Nut	1	SS 304 / SS 316
7	Stem	1	SS 304 / SS 316
8	Stem Washer	1	RPTFE
9	Packing	1	RPTFE
10	Gland	1	Stainless Steel
11	Handle	1	Stainless Steel
12	Spring Washer	1	Stainless Steel
13	Nut	1	Stainless Steel

TEST PRESSURE

Nominal Pressure	:	1000 Psi (6.9 MPa)
Hydrostatic Shell Test Pressure	:	1500 Psi (10.4 MPa)
Hydrostatic Seat Test Pressure	:	1100 Psi (7.6 MPa)
Gas Seat Test Pressure	:	90 Psi (0.6 MPa)

DIMENSION TABLE (MM)

Size		L	d	BSPT /NPT	Lo	H	Weight (Kg)
DN	Inch						
8	1/4	40	5	1/4	70	33.5	0.07
10	3/8	45	7	3/8	70	35	0.10
15	1/2	55	9	1/2	80	39	0.15
20	3/4	60	11.5	3/4	95	49	0.24
25	1	70	15	1	105	54	0.38
32	1-1/4	80	19.5	1-1/4	120	65.5	0.64
40	1-1/2	86	25	1-1/2	140	72	0.85
50	2	101	32	2	150	81	1.34
65	2-1/2	119	38	2-1/2	170	96.5	2.24
80	3	140	49	3	185	105	3.00
100	4	186	64	4	220	118	To be advised