

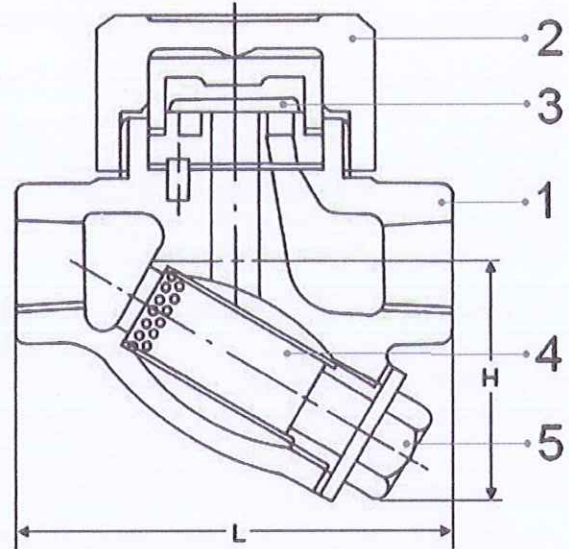

UNIMECH GROUP, MALAYSIA

A MEMBER OF UNIMECH GROUP, MALAYSIA

## CAST IRON STEAM TRAP CLASS 16 SCREWED END



### Technical Data

#### Dimension in mm

SIZES		L	H	WT. (KG)
DN	in.			
15	1/2	97	67	1.2
20	3/4	105	75	1.5
25	1	112	90	2.0
32	1.1/4	184	105	6.5
40	1.1/2	187	110	7.3
50	2	201	130	10.0

#### Material

No.	PART	MATERIAL
1	BODY	FC 20
2	BONNET	FC 20
3	DISC	SUS 304
4	SCREEN	SUS 304
5	DRAIN PLUG	FC 20
6	SEAT	SUS 410
7	SEAL	PTFE
8	PACKING	PTFE

#### Features

- \* Thread: BS 21
- \* Working Pressure: 120°C
- \* Max. Temperature: 220°C

#### Pressure Test

Hydrostatic Test	
Body	32 kgf/cm <sup>2</sup>

#### Working Pressure

Water	0.3 ~ 16 kgf/cm <sup>2</sup>
-------	------------------------------

Capacity	Kgf/H												
P kg/cm <sup>2</sup>	0.3	0.6	1	2	3	4	5	6	8	10	12	14	16
15 - 25	183	220	253	300	345	385	420	450	510	570	630	690	740
32	350	410	490	620	730	820	900	960	1080	1200	1320	1440	1560
40	440	520	610	780	900	1000	1090	1180	1350	1500	1650	1790	1930
50	460	560	670	850	1000	1110	1220	1320	1500	1680	1860	2030	2200

DISTRIBUTED BY

#### WISMA UNIMECH

4934, JALAN CHAIN FERRY,  
12100 BUTTERWORTH, MALAYSIA.  
TEL : 04-332 8823 FAX : 04-3325176  
WEBSITE : www.unimechgroup.com  
Email : jl.lim@unimechgroup.com



The contents of this literature are for informative purposes only. Unimech is not responsible for suitability or compatibility of these products in relation to system requirement. For specific requirements, consult Unimech or its distributors. Unimech reserves the right to change or modify product design without prior notice.