



UNIMECH GROUP, MALAYSIA



A MEMBER OF UNIMECH GROUP, MALAYSIA

WAFER TYPE BUTTERFLY VALVE UNIVERSAL FLANGED (PINLESS)

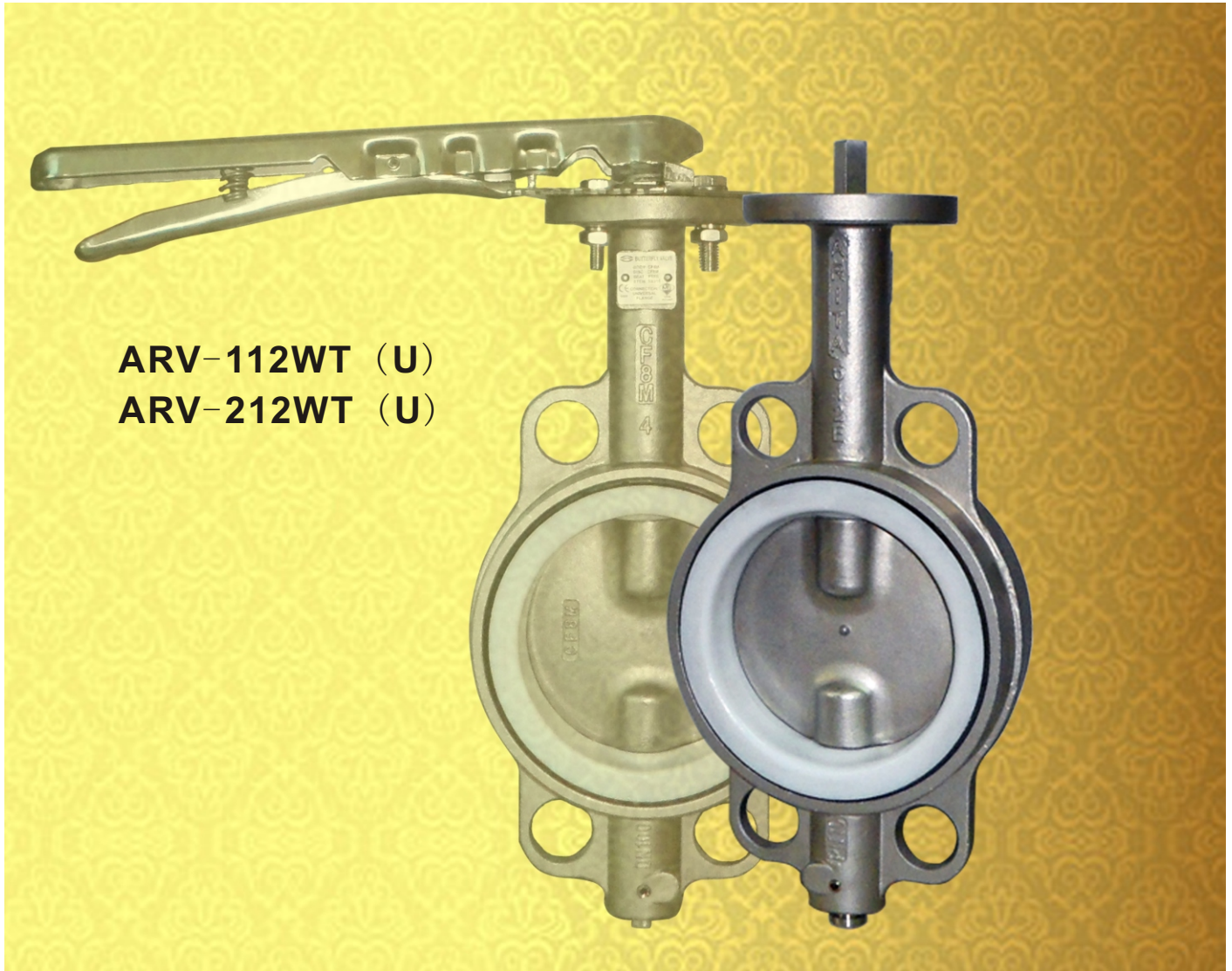

The new stainless steel body design offers esthetic appearance, strength and a universal flange connection that match to several international standards. Its top flange is designed to ISO 5211 for the direct mounting of gear operator or actuator which eliminates the cost of mounting bracket. The stainless steel body provides good resistance to corrosion and abrasion. Arita offers various materials for the valves seat to meet the various requirements of customers. The fine finishing of seat surfaces and the polished edge of disc give good sealing and reduction in operating torque.

 ISO 9001:2008 CERTIFICATE NO. 0436-2002-AQ-RGC-RW1-Rev.1	 Pressure accessory CERTIFICATE NO. 03-SKM-PED-B1-296225-00	 CE Notified Body No. 0575 CERTIFICATE NO. PED-D-59	 Det Norske Veritas Rules for Classification of Ships Det Norske Veritas Standards for Certification 2.9 No.5.794.40 CERTIFICATE NO. P-12513	 BS EN 593:2004 PA046601
---	---	---	---	---

Dimensions In mm (UNIVERSAL)

SIZES		A	B	C	ØD1	ØD2	ØD3	a°	ØE1	ØE2	ØE3	ØE4	TORQUE (Nm)		Cv	WT. (KG)
DN	In.												PN 10	PN 16		
50	2	156	80	42.0	52.9	120.00	24.0	45.00	50	7	65	35	14	15	31	2.7
65	2 1/2	162	89	44.7	64.5	136.13	28.0	45.00	50	7	65	35	15	17	55	3.2
80	3	170	95	45.2	78.8	152.40 154.50	19.0 24.5	45.00 22.50	50	7	65	35	22	23	87	3.6
100	4	185	114	52.1	104.3	182.50	27.0	22.50	70	10	90	55	37	40	140	5.0
125	5	207	127	54.4	123.3	212.50	26.0	22.50	70	10	90	55	58	62	224	6.9
150	6	216	139	55.8	156.0	238.12	26.0	22.50	70	10	90	55	94	102	328	8.6
200	8	256	175	60.6	202.5	293.00 296.07	26.0 25.0	15.00 22.50	102	12	125	70	174	192	572	15.5
250	10	248	203	65.6	250.8	357.00	30.5	15.00	102	12	125	70	286	323	837	26.8
300	12	280	242	76.9	301.6	400.00 416.70 445.00	25.0 40.5 25.0	11.25 15.00 11.25	102	12	125	70	429	490	1241	35.1
350	14	368	267	75.0	333.5	470.00 476.20	28.0 28.4	11.25 15.00	102	12	125	70	550	625	1564	45.6
400	16	400	297	85.7	389.6	510.00 539.70	27.0 28.4	11.25 11.25	140	18	175	100	755	846	2087	92.2
450	18	422	315	104.6	440.5	577.80 565.00 585.00	31.8 27.0 31.0	11.25 9.00 9.00	140	18	175	100	1012	1131	2681	122.0
500	20	480	348	130.3	491.6	635.00 620.00 650.00	31.8 28.0 34.0	9.00 9.00 9.00	140	18	175	100	1350	1431	3350	202.0
600	24	562	444	151.4	592.5	749.30 725 (770) 730.00	35.1 31 (37) 33.0	9.00 9.00 7.50	165	23	210	130	2111	2301	4907	230.0

Dimension included ANSI125/150, JIS10K, PN10/PN16, (EN1092-2, BS4504, DIN2501) AS2129 EXCLUDING 16", 18" and 24"
 Note : Cv = US Gallon per minutes

Note : Cv = US Gallon per minutes

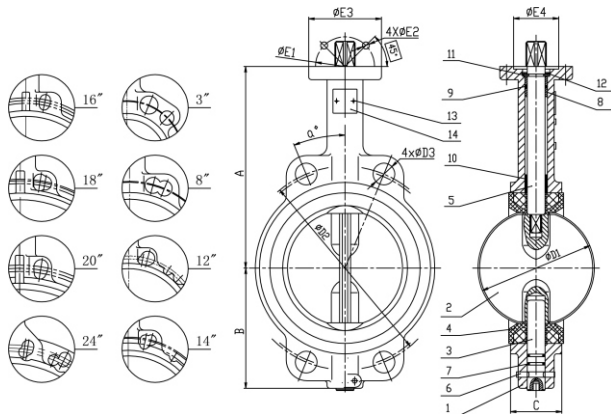

Pressure Test

Working Pressure	1.0 MPa	1.6 MPa	10K	ANSI 125		ANSI 150
SIZE	2"-40"	2"-24"	2"-24"	2"-12"	14"-24"	2"-12"
Hydrostatic Seal	1.1 MPa	1.76 MPa	1.54 MPa	1.52 MPa	1.14 MPa	2.2 MPa
Test Body	1.5 MPa	2.4 MPa	2.1 MPa	2.1 MPa	1.55 MPa	3.0 MPa

Working Temperature

Temperature °C	-10 ~ 80	-15 ~ 140	-20 ~ 150	-20 ~ 180
Seat Material	NBR	EPDM	VITON	PTFE

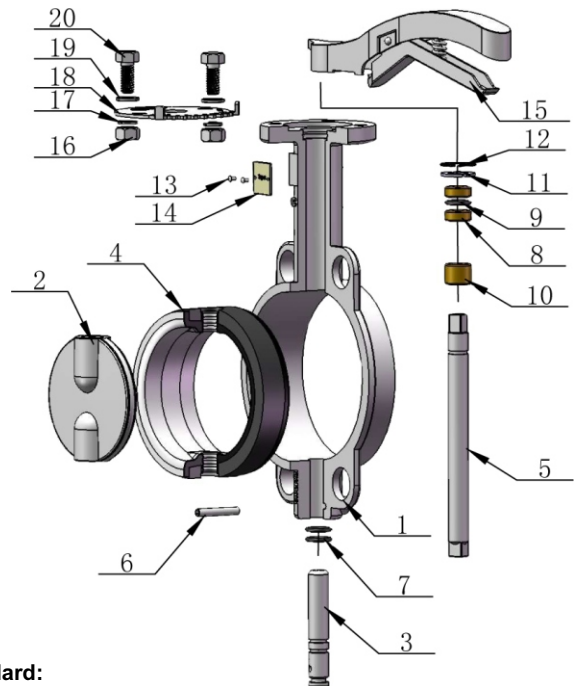

Material

No.	PART	QTY.	MATERIAL
1	BODY	1	CF8 / CF8M / WCB
2	DISC	1	COATING KYNAR/PTFE/ ALUMINIUM BRONZE/CF8/CF8M/POLISHED
3	LOWER STEM	1	SS 416 / 316 / 431
4	SEAT	1	PTFE/NBR/EPDM/VITON
5	UPPER STEM	1	SS 416 / 316 / 431
6	LOCK PIN	1	SUS 304 / SUS 316
7	LOWER 'O' RING	2	NBR / EPDM / VITON
8	BUSHING	2	PTFE
9	'O' RING	1	NBR / EPDM / VITON
10	BUSHING	1	PTFE
11	HALF RING	2	SS 416
12	RETAINER RING	1	SPRING STEEL
13	RIVET	2	ALUMINIUM
14	NAMEPLATE	1	ALUMINIUM
15	HANDLE	1	SUS 316
16	NUT	2	SUS 304 / SUS 316
17	SPRING WASHER	2	SUS 304 / SUS 316
18	INDICATOR	1	SUS 304
19	WASHER	2	SUS 304 / SUS 316
20	BOLT	2	SUS 304 / SUS 316

Standard:

Design Standard	: BS EN593
Face to Face	: BS EN558-1
Flange	: EN 1092-1 PN10/16 JIS B2210 10K DIN 2501 PN10/16 ANSI B16 125/150
Top Flange	: ISO 5211
Test Inspection	: BS EN 12266-1 / API 598

The contents of this literature are for informative purposes only.

Arita is not responsible for suitability or compatibility of these products in relation to system requirement. For specific requirements, consult Arita or its distributors. Arita reserves the right to change or modify product design without prior notice.

