

## STEEL BUTT-WELDING PIPE FITTINGS

**90° LONG RADIUS ELBOWS**

**SCH 5S, SCH 10S, SCH 40, SCH 80**

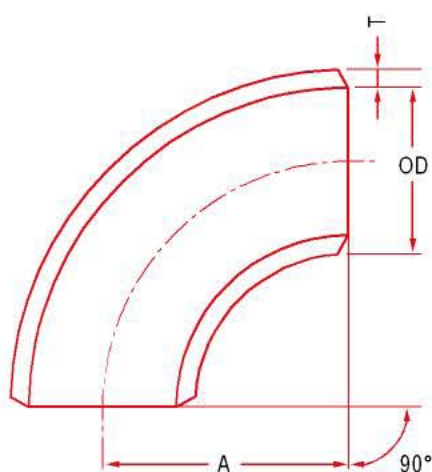

### DIMENSIONS

Unit: inch

Nominal Pipe Size	Outside Dia. (OD)	Wall Thickness (T)				Center to End A
		SCH 5S	SCH 10S	SCH 40S	SCH 80S	
3/8	0.680	0.047	0.065	0.091	0.126	1.50
1/2	0.840	0.065	0.083	0.109	0.147	1.50
3/4	1.050	0.065	0.083	0.113	0.154	1.12
1	1.315	0.065	0.109	0.133	0.179	1.50
1 1/4	1.660	0.065	0.109	0.140	0.191	1.88
1 1/2	1.900	0.065	0.109	0.145	0.200	2.25
2	2.375	0.065	0.109	0.154	0.218	3.00
2 1/2	2.875	0.083	0.120	0.203	0.276	3.75
3	3.500	0.083	0.120	0.216	0.300	4.50
3 1/2	4.000	0.083	0.120	0.226	0.318	5.25
4	4.500	0.083	0.120	0.237	0.337	6.00
5	5.563	0.109	0.134	0.258	0.375	7.50
6	6.625	0.109	0.134	0.280	0.432	9.00
8	8.625	0.109	0.148	0.322	0.500	12.00
10	10.750	0.134	0.165	0.365	0.500	15.00
12	12.750	0.156	0.180	0.375	0.500	18.00

### WEIGHTS

Unit: kg

Nominal Pipe Size	SCH 5S	SCH 10S	SCH 40S	SCH 80S
3/8	0.038	0.058	0.073	0.085
1/2	0.049	0.060	0.076	0.097
3/4	0.062	0.057	0.076	0.098
1	0.078	0.156	0.150	0.193
1 1/4	0.125	0.201	0.253	0.334
1 1/2	0.170	0.279	0.363	0.485
2	0.286	0.470	0.651	0.894
2 1/2	0.576	0.786	1.29	1.70
3	0.810	1.160	2.02	2.74
3 1/2	1.08	1.550	2.84	3.90
4	1.39	2.000	3.84	5.34
5	2.83	3.460	6.51	9.25
6	4.03	4.960	10.1	15.3
8	7.06	9.550	20.3	30.9
10	13.20	16.60	36.0	48.8
12	22.30	25.80	53.0	69.9